

# Catálogo Técnico



Perfeita para seus projetos mais importantes





## Uma linha consagrada e inovadora.

A Linha Suprema da Alcoa já está consolidada no mercado da construção civil há aproximadamente 10 anos, sendo utilizada em todas as regiões do Brasil com grande aceitação e alto índice de satisfação dos clientes. Atualmente, são mais de 3 milhões de m<sup>2</sup> produzidos e instalados no país, e também exportados para a América Latina. Além disso, conta com centenas de fabricantes, com equipamentos e mão-de-obra especializada, atuando no Brasil e em outras localidades.



Inovadora em todos os sentidos, a Linha Suprema incorporou a mudança do sistema artesanal de construção de esquadrias para o sistema industrializado sem perder o conceito de design diferenciado.

Em permanente desenvolvimento e contínua atualização, a linha foi se aperfeiçoando ao longo do tempo e ampliando sua família de produtos. Entre os lançamentos mais recentes, podemos destacar a porta de correr com fechadura e as portas de giro.

A linha Suprema possui design robusto e componentes exclusivos, mas mantém sua competitividade. Extremamente versátil, oferece as melhores soluções estéticas para os mais diversos projetos de arquitetura.

Empregando a mais avançada tecnologia em seu processo de fabricação, a Linha Suprema também proporciona maior produtividade e qualidade em sua industrialização. Além disso, apresenta um desempenho superior ao estabelecido pelas Normas Brasileiras.

Linha Suprema. Flexibilidade de projetos e desempenho superior.

### Mais liberdade de escolha

A Linha Suprema se destaca pela versatilidade, permitindo ao fabricante construir janelas e portas com diferentes características.

Apresenta diversas tipologias, que vão de janelas de correr a basculantes, além de portas de giro, entre outras.

### PRINCIPAIS VANTAGENS

- Diversidade de tipologias
- Visual robusto
- Componentes exclusivos
- Consagrada no mercado



## Perfis



## Envidraçamento



## Componentes



Os extrudados de alumínio da Linha Suprema são produzidos na liga Alcoa 6060-T5. Podem receber anodização ou pintura eletrostática a pó, que garante longa vida útil às esquadrias e confere um diferencial estético ao projeto.

Comporta vidros de 4 a 6 m

Por ser uma linha extremamente versátil, os componentes variam conforme o modelo de cada projeto. A finalidade desses componentes é facilitar o manuseio da esquadria, proporcionando estabilidade e resistência ao sistema, além de impedir vazamentos e conferir beleza e harmonia estética ao conjunto. Entre eles podemos destacar:

## Design



## Acabamento



## Desempenho



- Maçanetas com fechadura para portas de giro
- Roldanas em delrin com ou sem regulagem
- Fechos e travas de segurança
- Dobradiças para portas de giro

- Fechaduras para porta de correr

A harmonia dos encaixes entre os perfis garante maior equilíbrio ao conjunto. É uma linha com visual limpo e robusto.

o que propicia velocidade, na usinagem, montagem e melhor aproveitamento do material. Na junção dos cantos, em particular nas folhas, os perfis foram projetados para que a largura se encaixe na altura, resultando em um ótimo acabamento. Além disso, estampos pneumáticos especialmente desenvolvidos pela Alcoa garantem usinagens perfeitas e acabamento impecável, com alto índice de produtividade.

- Caixa de dreno inferior e vedador superior
- Guias de nylon das folhas de correr: eliminam as vibrações causadas pelo vento e manuseio, garantindo um funcionamento suave

Conforme as exigências das Normas Brasileiras, a Linha Suprema foi submetida a testes nos mais conceituados institutos de análise do país, que comprovaram a eficiência do sistema empregado em todos os requisitos.

O sistema foi desenvolvido com ângulos a 90 graus,

As persianas das janelas podem ser fixas ou projetantes. As persianas externas de enrolar tanto das janelas como das portas têm acionamento manual ou motorizado - controle remoto ou interruptor.



<b>1</b>	Normas ABNT ..... 5
<b>2</b>	Resultados de ensaios ..... 9
<b>3</b>	Tipologia ..... 17
<b>4</b>	Diagramas de dimensões ..... 19
<b>5</b>	Perfis ..... 37
<b>6</b>	Componentes ..... 75
<b>7</b>	Estampos / Usinagens ..... 109
<b>8</b>	Montagens ..... 115





## Capítulo 1

Normas ABNT

No Brasil, o comportamento estrutural de uma esquadria está regulamentada pela Norma NBR 10821.

Esta norma fixa as condições de desempenho de caixilhos em edificações residenciais e comerciais e visa assegurar ao consumidor, o recebimento de produtos com condições mínimas exigíveis de desempenho, especificamente quanto à resistência a cargas uniformemente distribuídas e que apresenta um roteiro de cálculo da pressão de ensaio (vento e vedação).

Figura 1



Gráfico das isopletas da velocidade básica do vento: "V" em m/s no Brasil. ▶

Tabela 1

**Pressão de ensaio de cargas uniformemente distribuídas.**

Classe	Região do País	Pressão de projeto Pp em Pa	Pressão de sucção, em Pa, P <sub>x0,8</sub>	Pressão de ensaio P= P <sub>p</sub> x1,5 em Pa
Residencial Unifamiliar ou Comercial simples até 2 pavimentos Normal	I	300	350	450
	II	400	500	600
	III	550	650	800
	IV	650	800	950
	V	850	1000	1250
Residencial ou Comercial até 4 pavimentos ou 12 metros Melhorada	I	450	550	650
	II	600	700	900
	III	800	950	1200
	IV	1000	1200	1500
	V	1200	1450	1800
Comercial pesada ou edifícios residenciais com mais de 5 pavimentos Reforçada	Todas as regiões	Calcular conforme NBR 6123	Calcular conforme NBR 6123	Calcular conforme NBR 6123
Arquiteturas especiais (Shopping, industriais, hospitais, etc.) Excepcional	Todas as regiões	Calcular conforme NBR 6123	Calcular conforme NBR 6123	Calcular conforme NBR 6123

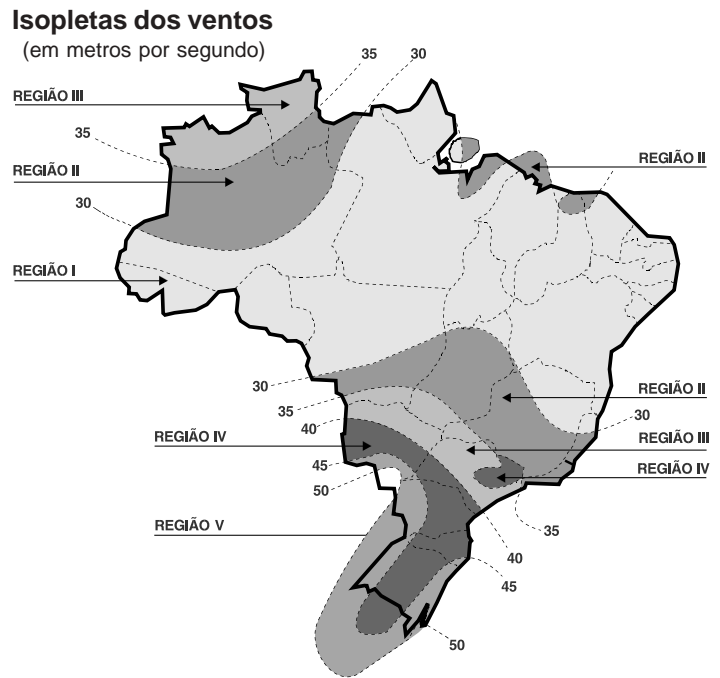
**Notas:** 1) Na classe reforçada, os valores de pressão, calculados conforme a NBR-6123, deverão ser, pelo menos, iguais aos valores das pressões de ensaio da classe Melhorada.  
2) Nos casos de arquiteturas especiais da classe Excepcional, os valores de pressão de ensaio, calculados conforme a NBR-6123, quando inferiores aos valores da classe Melhorada, deverão ser justificados através de ensaios em túneis de vento ou planilhas de cálculo e assinadas por um responsável técnico.

Tabela 2

**Pressão de ensaio de estanqueidade à água**

Classe de utilização	Região do País	Pressão de estanqueidade à água - Pressão de projeto de vento - Pp x 0,15, em Pa
Residencial Unifamiliar ou Comercial simples - até dois pavimentos Normal	I	40
	II	60
	III	80
	IV	100
	V	120
Residencial ou Comercial até 4 pavimentos ou 12 metros Melhorada	I	60
	II	90
	III	120
	IV	150
	V	180
Comercial pesada ou edifícios residenciais com mais de 5 pavimentos Reforçada	Todas as regiões	Pressões de ensaio = o maior dos dois valores. 0,15 x Pp (pressão de projeto das cargas de vento) e os valores das pressões da classe Melhorada.
Arquiteturas especiais (Shopping, industriais, hospitais, etc.) Excepcional	Todas as regiões	Pressões de ensaio= o maior dos dois valores: 0,15 x Pp (pressão de projeto das cargas de vento) e os valores das pressões de classe Melhorada.

Tabela 3  
Fator topográfico de correção  $s_1$

Topografia	$S_1$
Vales profundos, protegidos de todos os ventos.	0,9
Encostas e cristas de morro em que ocorre aceleração do vento.	1,1
Vales com efeitos de afunilamento.	
Todos os casos, exceto os acima citados.	1

Tabela 4  
Fator de Correção  $s_2$   
Rugosidade do terreno, dimensões da edificação e altura acima do terreno.

Altura acima do terreno H (m)	CATEGORIA			
	Terreno aberto sem obstruções	Terreno aberto com poucas obstruções	Terreno com muitas obstruções; pequenas cidades; subúrbios de grandes cidades	Terreno com obstruções grandes e frequentes Ex: centros de grandes cidades
3	0,83	0,72	0,64	0,56
5	0,88	0,79	0,70	0,60
10	1,00	0,93	0,78	0,67
15	1,03	1,00	0,88	0,74
20	1,06	1,03	0,95	0,79
30	1,09	1,07	1,01	0,90
40	1,12	1,10	1,05	0,97
50	1,14	1,12	1,08	1,02
60	1,15	1,14	1,10	1,05
80	1,18	1,17	1,13	1,10
100	1,20	1,19	1,16	1,13
120	1,22	1,21	1,18	1,15
140	1,24	1,22	1,20	1,17
160	1,25	1,24	1,21	1,19
180	1,26	1,25	1,23	1,20
200	1,27	1,26	1,24	1,22

Fator Probabilístico  $s_3 = 0,88$

## Descrição do exemplo a ser calculado

Obra localizada em São Paulo, REGIÃO III, em local de terreno aberto e poucas obstruções, com 16 pavimentos ( $\pm 50$  metros).  
Vide tabela 4, 3.<sup>a</sup> coluna.

## EXEMPLO SIMPLIFICADO DE PRESSÃO DE ENSAIO NA CLASSE REFORÇADA.

**P = Pressão de Ensaio**

$$P = q \cdot (C_e - C_i)$$

onde:

**P** = Pressão de Ensaio (Pa)

**q** = Pressão de Obstrução (Pa)

**Ce-Ci** = Para este exemplo, adotamos o valor de 1,5 para **(Ce-Ci)** que é um coeficiente válido para condições desfavoráveis.

**q = Pressão de Obstrução**

$$q = \frac{(VK)^2}{1,6}$$

onde:

**VK = Velocidade Características do Vento**

$$VK = V_0 \cdot S_1 \cdot S_2 \cdot S_3$$

onde:

- V<sub>0</sub>** Velocidade Básica do Vento em m/s, dada pelas isopletas. (Figura 1)
- S<sub>1</sub>** Fator Topográfico de Correção, dado pela tabela 3.
- S<sub>2</sub>** Fator de Correção que considera as influências da rugosidade do terreno, das dimensões da edificação e de sua altura sobre o terreno, dado pela tabela 4.
- S<sub>3</sub>** Fator Probabilístico, de valor igual a 0,88.

$$1) VK = V_0 \cdot S_1 \cdot S_2 \cdot S_3$$

onde:

$$\begin{aligned} V_0 &= 40 \text{ m/s} \\ S_1 &= 1 \\ S_2 &= 1,12 \\ S_3 &= 0,88 \\ VK &= 39,42 \text{ m/s} \end{aligned}$$

$$2) q = \frac{(VK)^2}{1,6}$$

$$q = 971 \text{ Pa (também é igual a Pressão de Projeto = Pp)}$$

$$3) P = q \cdot (C_e - C_i)$$

$$P = 1457 \text{ Pa ou } 145,7 \text{ kg/m}^2$$

## Conclusão deste exemplo:

a) Para efeito de cálculo estrutural, temos que utilizar o valor de

$$145,7 \text{ kg/m}^2 \text{ ou } 1457 \text{ Pa}$$

b) Para efeito de ensaio de estanqueidade à água, temos que utilizar o valor que representa 15% do valor da Pressão de Projeto, que é

$$97,1 \text{ kg/m}^2 \text{ ou } 971 \text{ Pa,}$$

cujo valor é

$$14,6 \text{ kg/m}^2 \text{ ou } 140 \text{ Pa}$$





## Capítulo 2

Resultados  
dos  
ensaio

Ref.: E/62.766/00  
Fl.: 1/7

**RELATÓRIO DE ENSAIO E/62.766/00**

**ESQUADRIA DE ALUMÍNIO**  
**DETERMINAÇÕES DIVERSAS**

Intr. ressado: **ALCOA ALUMÍNIO S/A.**  
Rua Felipe Camarão, 454 - Utinga  
09220-902 - Santo André - S.P.

Ensaio(s): (13.150/A)

**1. MATERIAL ENSAIADO:**

Um protótipo de esquadria de alumínio, enviado ao laboratório pelo interessado em 03/02/00, apresentando as seguintes características:

**1.1 - Fabricante**  
ALCOA ALUMÍNIO S/A.

**1.2 - Tipo**  
Janela de correr com 2 folhas móveis de vidro do tipo projetante-deslizante (maxim-ar) e 2 folhas fixas, possuindo um fecho em cada folha móvel, localizado na travessa inferior de cada folha, conforme o desenho a seguir:

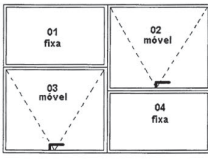

**1.3 - Dimensões do protótipo**

- Vão: 1500mm x 1505mm.
- Dimensões das folhas móveis:
  - 767mm x 735mm (folha 01);
  - 735mm x 752mm (folha 02);
  - 732mm x 753mm (folha 03);
  - 767mm x 730mm (folha 04);
- Espessura do vidro: 3mm.
- Comprimento total de junta móvel: 5,94m.
- Área aberta total: 1,10m<sup>2</sup>.

Os resultados apresentados no presente documento referem-se exclusivamente à amostra ensaiada. A reprodução deste documento somente poderá ser feita na íntegra e a sua utilização para fins promocionais, depende de aprovação prévia.

SÃO PAULO: RUA AQUINOS, 111 - S.P. - CEP 05036-070 - FONE: (011) 861-0833 - FAX: (011) 861-0170 - TELEX (011) 82802 LAFB BR  
Campinas - São José dos Campos - Santos - Bauri - Araçatuba - São José do Rio Preto - Sorocaba - Rio de Janeiro (RJ)  
00.00.10001 - A3049

Ref.: E/62.766/00  
Fl.: 2/7

**1.4 - Fixação do vão**  
O marco foi fixado com parafusos em um vão acabado de blocos cerâmicos, revestido com argamassa.

**1.5 - Sistema de vedação**

- **Silicone:**
  - Nos encontros dos montantes do marco com a alvenaria em toda extensão.
  - No encontro da travessa superior do marco com a alvenaria em toda extensão.
  - Nos encontros a 45° e 90° dos perfis das folhas móveis.
  - No encontro da pingadeira com a travessa superior do marco.
  - No encontro da pingadeira da folha móvel inferior com a travessa central.
  - Nos encontros a 90° das baguetes, nas folhas fixas.
  - Nos encontros a 90° dos perfis das travessas superior e inferior do marco com o montante central.
  - Nos encontros a 90° das travessas centrais com os montantes laterais e montante central do marco.
  - Nos encontros a 45° das travessas superior e inferior com os montantes laterais do marco.
- **Guarnição de borracha:**
  - Na fixação e na vedação dos vidros das folhas móveis em todo o perímetro do lado interno.
  - Na fixação e na vedação dos vidros das folhas fixas em todo o perímetro do lado externo.
  - Na parte interna das folhas móveis, nos encontros laterais e inferior com o marco.
  - No encontro do marco com as folhas móveis, em todo o perímetro.
  - Na parte interna das pingadeiras, no encontro com as travessas das folhas móveis.
- **Fita de vedação:**
  - No encontro do marco com o contra marco em todo o perímetro.
  - Nos encontros dos vidros com o quadro.

**2. ENSAIOS REALIZADOS - METODOLOGIAS:**

**2.1 - Verificação da Penetração de Ar - MB 1225.**

**2.2 - Verificação da Estanqueidade à Água - MB 1226.**

Os resultados apresentados no presente documento referem-se exclusivamente à amostra ensaiada. A reprodução deste documento somente poderá ser feita na íntegra e a sua utilização para fins promocionais, depende de aprovação prévia.

SÃO PAULO: RUA AQUINOS, 111 - S.P. - CEP 05036-070 - FONE: (011) 861-0833 - FAX: (011) 861-0170 - TELEX (011) 82802 LAFB BR  
Campinas - São José dos Campos - Santos - Bauri - Araçatuba - São José do Rio Preto - Sorocaba - Rio de Janeiro (RJ)  
00.00.10001 - A3049

Ref.: E/62.766/00  
Fl.: 3/7

**3. RESULTADOS OBTIDOS:**

**3.1 - Penetração de Ar.**

Pressão na Câmara (Pa)	Vazão de ar (m³/h)			Vazão de ar através	
	Com Vedação	Sem Vedação	Perdas	Área Aberta (m²/h . m²)	Juntas Abertas (m³/h . m . linear)
135	150,93	150,93	0,50	0,45	0,08
Limites máximos EB 1968					
				60	12

**3.2 - Estanqueidade à Água.**

Da tabela a seguir constam os valores das pressões adotadas em função da região de utilização, os tempos de aplicação e as observações visuais efetuadas durante o ensaio.

A vazão de água aplicada foi 4 l/min . m<sup>2</sup>.

Região de Utilização da Janela	Pressão de Ensaio (Pa)	Tempo (min)	Observações
Região IV (São Paulo)	60 (1ª etapa)	15	- nenhuma ocorrência.
	110 (2ª etapa)	15	- PI no encontro à 90° da travessa central do lado esquerdo com o montante do marco
Pressões utilizadas à pedido do interessado	150	15	- PI no encontro à 90° da travessa central do lado esquerdo com o montante do marco
	200	10	- PI no encontro à 90° da travessa central do lado esquerdo com o montante do marco
	250	10	- PI no encontro à 90° da travessa central do lado esquerdo com o montante do marco, com aumento na quantidade de água acumulada na travessa
	250(*)	10	- PI no encontro à 90° da travessa central do lado esquerdo com o montante do marco, com aumento na quantidade de água acumulada na travessa
(**)	350	3	- PI no encontro à 90° da travessa central do lado esquerdo com o montante do marco
(***)	300	5	- PI no encontro à 90° da travessa central do lado esquerdo com o montante do marco

Os resultados apresentados no presente documento referem-se exclusivamente à amostra ensaiada. A reprodução deste documento somente poderá ser feita na íntegra e a sua utilização para fins promocionais, depende de aprovação prévia.

SÃO PAULO: RUA AQUINOS, 111 - S.P. - CEP 05036-070 - FONE: (011) 861-0833 - FAX: (011) 861-0170 - TELEX (011) 82802 LAFB BR  
Campinas - São José dos Campos - Santos - Bauri - Araçatuba - São José do Rio Preto - Sorocaba - Rio de Janeiro (RJ)  
00.00.10001 - A3049

Ref.: E/62.766/00  
Fl.: 4/7

(\*) Foi retirada a guarnição de borracha da folha 03, permanecendo assim até o término do ensaio.

(\*\*) Rajadas de vento com água.

(\*\*\*) Ensaio realizado após a aplicação de rajadas de vento.

**3.2.1 - De acordo com a EB 1968, a esquadria deverá apresentar o seguinte desempenho, no ensaio de Estanqueidade à Água:**

- 1ª etapa: estanqueidade total.
- 2ª etapa: não apresentar permeabilidade excessiva (ocorrência de infiltração pela esquadria, com escorrimento da água pelas paredes ou pelos componentes sobre os quais está fixada).

**4. OBSERVAÇÕES:**

**4.1 - É PARTE INTEGRANTE DESTES RELATÓRIO E O COMPLEMENTO, O DESENHO DA ESQUADRIA DE ALUMÍNIO CARIMBADO E RUBRICADO POR ESTE LABORATÓRIO. Encontra-se também anexa, documentação fotográfica (fotos nºs. 01 a 04).**

**4.2 - O protótipo atendeu as exigências da EB 1968 quanto aos ensaios de verificação da penetração de ar e da estanqueidade à água.**

**4.3 - Pedido de ensaio - PE 21.353.**

**4.4 - Ensaio finalizado em maio de 2.000.**

**NOTA IMPORTANTE:**  
Os resultados têm significação restrita, aplicando-se tão somente à amostra ensaiada.

São Paulo, 24 de maio de 2.000.

**L.A. FALCÃO BAUER LTDA**  
Centro Tecnológico de Controle da Qualidade

**L.A. FALCÃO BAUER LTDA**  
Centro Tecnológico de Controle da Qualidade

**FABIOLA RAGO**  
Engª Civil - CREA nº 5060234744

**ENG. VERA L. FALCÃO BAUER LOURENÇO**  
Diretora - CREA nº 0600421408

Os resultados apresentados no presente documento referem-se exclusivamente à amostra ensaiada. A reprodução deste documento somente poderá ser feita na íntegra e a sua utilização para fins promocionais, depende de aprovação prévia.

SÃO PAULO: RUA AQUINOS, 111 - S.P. - CEP 05036-070 - FONE: (011) 861-0833 - FAX: (011) 861-0170 - TELEX (011) 82802 LAFB BR  
Campinas - São José dos Campos - Santos - Bauri - Araçatuba - São José do Rio Preto - Sorocaba - Rio de Janeiro (RJ)  
00.00.10001 - A3049







Ref.: E/02.766/00  
 Fl.: 57

**A N E X O**

- Dusenho da esquadria com carimbo e rubrica do laboratório.  
 - Documentação Fotográfica (Fotos nº01 a 04)

Os resultados apresentados no presente documento referem-se exclusivamente à amostra ensaiada. A reprodução deste documento somente poderá ser feita na íntegra e, a sua utilização, para fins promocionais, depende de aprovação prévia.

SÃO PAULO: RUA AQUINOS, 111 - S.P. - CEP 05036-070 - FONE: (011) 861-0833 - FAX: (011) 861-0170 - TELEX (011) 82802 LAFB BR  
 Campinas - São José dos Campos - Santos - Bauri - Araraquara - São José do Rio Preto - Sorocaba - Rio de Janeiro (RJ)  
 90 09. 1004 - 42045

Ref.: E/02.766/00  
 Fl.: 67

Foto nº. 01  
 Verificação da penetração de ar (com vedação).







Foto nº. 02  
 Verificação da estanqueidade à água.

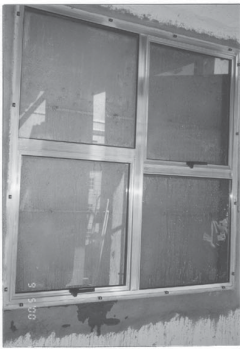

Os resultados apresentados no presente documento referem-se exclusivamente à amostra ensaiada. A reprodução deste documento somente poderá ser feita na íntegra e, a sua utilização, para fins promocionais, depende de aprovação prévia.

SÃO PAULO: RUA AQUINOS, 111 - S.P. - CEP 05036-070 - FONE: (011) 861-0833 - FAX: (011) 861-0170 - TELEX (011) 82802 LAFB BR  
 Campinas - São José dos Campos - Santos - Bauri - Araraquara - São José do Rio Preto - Sorocaba - Rio de Janeiro (RJ)  
 90 09. 1004 - 42045

Ref.: E/02.766/00  
 Fl.: 77

Foto nº. 03  
 Vista externa do protótipo.





Foto nº. 04  
 Vista externa do protótipo.



Os resultados apresentados no presente documento referem-se exclusivamente à amostra ensaiada. A reprodução deste documento somente poderá ser feita na íntegra e, a sua utilização, para fins promocionais, depende de aprovação prévia.

SÃO PAULO: RUA AQUINOS, 111 - S.P. - CEP 05036-070 - FONE: (011) 861-0833 - FAX: (011) 861-0170 - TELEX (011) 82802 LAFB BR  
 Campinas - São José dos Campos - Santos - Bauri - Araraquara - São José do Rio Preto - Sorocaba - Rio de Janeiro (RJ)  
 90 09. 1004 - 42045



**la.falcão bauer**   
centro tecnológico de controle da qualidade

RELATÓRIO E/45.864/95

**PORTA DE ALUMÍNIO**  
**DETERMINAÇÕES DIVERSAS**

Interessado: **ALCAN ALUMÍNIO DO BRASIL S/A.**  
Rua Felipe Camarão, 414  
**SANTO ANDRÉ - SP**

Obra : **Edifício Olinto Rodrigues - Campinas**  
(6563/B)

1. **MATERIAL ENSAIADO**

Um protótipo de porta de alumínio enviado ao laboratório pelo fabricante, apresentando as seguintes características:

1.1 - **Fabricante**  
CANBOX Esquadrias de Alumínio Ltda, com supervisão de projeto da CLIMA - Serviços Técnicos Industriais.

1.2 - **Tipo**  
Porta com a identificação SUPREMA, conforme desenho nº PC 000202, da Alcan Alumínio do Brasil S/A., constituída por duas folhas móveis do tipo de correr, com vidro, e com travessas intermediárias.  
Cada folha possuía um fecho, com chave, no montante lateral de encontro com o marco.

1.3 - **Dimensões do Protótipo**  
Vão: 1990 mm x 2174 mm.  
Dimensões das folhas: 990 mm x 2126 mm, cada uma.  
Espessura do vidro: 6 mm.  
Comprimento total de juntas abertas: 10,338 m.

*me*

SÃO PAULO: RUA AQUINOS, 111 - S.P. - CEP 05036-070 - FONE: (011) 861-0833 - FAX: (011) 861-0170 - TELEX (011) 82802 LAFB BR  
Campinas - São José dos Campos - Santos - Bauriú - Araraquara - São José do Rio Preto - Sorocaba - Rio de Janeiro (RJ)  
88 804.10001 - A3048

**la.falcão bauer**   
centro tecnológico de controle da qualidade

Ref.: E/45.864/95  
Fls.: 02/06

Área móvel aberta: 4,20 m<sup>2</sup>.

1.4 - **Fixação ao vão**  
O protótipo foi fixado por parafusos, em contramarco previamente chumbado em alvenaria de blocos cerâmicos.

1.5 - **Sistema de vedação**  
Silicone nos encontros com a alvenaria, na face externa; nos encontros a 90º de perfis do marco; nos encontros do perfil de arremate da soleira com o trilho inferior e com a alvenaria; na colocação do vidro, na face externa; nos encontros dos montantes com as travessas das folhas, na face externa; nos parafusos de fixação do marco; nos encontros dos montantes do marco com o perfil de arremate da soleira; nos encontros marco/contramarco.

Escovas nas travessas das folhas, em toda a extensão da largura; nos montantes laterais das folhas e no montante central da folha externa; nas travessas do marco, na região de encontro de montantes centrais das folhas.

Guarnição de borracha na colocação do vidro, na face interna.

O desenho anexo ilustra e complementa a descrição.

2. **ENSAIOS REALIZADOS - METODOLOGIAS**

2.1 - Verificação da Penetração de Ar - MB 1225.

2.2 - Verificação da Estanqueidade à Água - MB 1226.

2.3 - Comportamento sob Cargas Uniformemente Distribuídas - MB 1227.

Para a realização dos ensaios sob cargas uniformemente distribuídas, foram aplicados os fatores de correção com tidos no anexo da EB 1968, obrigatórios para edificações com altura superior a 10 m.

Foi considerada altura da edificação 54 m, em terreno aberto sem obstruções ao vento.

*me*

SÃO PAULO: RUA AQUINOS, 111 - S.P. - CEP 05036-070 - FONE: (011) 861-0833 - FAX: (011) 861-0170 - TELEX (011) 82802 LAFB BR  
Campinas - São José dos Campos - Santos - Bauriú - Araraquara - São José do Rio Preto - Sorocaba - Rio de Janeiro (RJ)  
88 804.10001 - A3048

**la.falcão bauer**   
centro tecnológico de controle da qualidade

Ref.: E/45.864/95  
Fls.: 03/06

-  $VK = V_0 \times S_1 \times S_2 \times S_3$   
 $VK = 48,9 \times 1,0 \times 1,14 \times 0,88 = 49,0 \text{ m/s}$  (velocidade característica).

-  $q = \frac{VK^2}{1,6} = 1500 \text{ Pa}$  (pressão de obstrução)

- pressão calculada:  $P = q \times (C_e - C_i)$   
 $P = q \times 0,94 = 1410 \text{ Pa}$ , sendo 0,94 o coeficiente aerodinâmico específico para a obra, fornecido pela supervisoradora do projeto (CLIMA).

Considerando que o valor mínimo de pressão para a Região IV é 1500 Pa, este foi o valor adotado como pressão de teste.

3. **RESULTADOS OBTIDOS**

3.1 - **Penetração de Ar**

PRESSÃO NA CÂMARA (Pa)	VAZÃO DE AR (m <sup>3</sup> /h)		PENETRAÇÃO DE AR ATRAVÉS	
	ALIMENTAÇÃO	PERDAS	ÁREA ABERTA (m <sup>3</sup> /h.m <sup>2</sup> )	JUNTAS ABERTAS (m <sup>3</sup> /h.m.línear)
135	298,80	230,40	16,3	6,6
Limites máximos EB 1968			60	12

3.2 - **Estanqueidade à Água**

Da tabela a seguir constam os valores das pressões adotadas em função da região de utilização, os tempos de aplicação e as observações visuais efetuadas durante o ensaio.

A vazão de água foi 4 l/min.m<sup>2</sup>.

*me*

SÃO PAULO: RUA AQUINOS, 111 - S.P. - CEP 05036-070 - FONE: (011) 861-0833 - FAX: (011) 861-0170 - TELEX (011) 82802 LAFB BR  
Campinas - São José dos Campos - Santos - Bauriú - Araraquara - São José do Rio Preto - Sorocaba - Rio de Janeiro (RJ)  
88 804.10001 - A3048

**la.falcão bauer**   
centro tecnológico de controle da qualidade

Ref.: E/45.864/95  
Fls.: 04/06

REGIÃO DE UTILIZAÇÃO DA PORTA	PRESSÃO DE ENSAIO (Pa)	TEMPO (MIN.)	OBSERVAÇÕES
IV (Campinas)	60 (1ª etapa)	15	Estanqueidade total
	110 (2ª etapa)	15	Estanqueidade total
V	140	15	Estanqueidade total

Para interpretação dos resultados, quando necessário, são adotadas as seguintes definições:

PI - **Permeabilidade Inicial:** infiltração de água pela esquadria não ocorrendo, entretanto, escorrimento pelas paredes ou pelos componentes sobre os quais está fixada. É tolerada na 2ª etapa de ensaio.

PE - **Permeabilidade Excessiva:** ocorrência de infiltração pela esquadria, com escorrimento de água pelas paredes ou pelos componentes sobre os quais está fixada.

3.2.1 - De acordo com a EB 1968, a esquadria deverá apresentar o seguinte desempenho, no ensaio de Estanqueidade à água.

- 1ª etapa: estanqueidade total.

- 2ª etapa: não apresentar permeabilidade excessiva (PE).

3.3 - **Comportamento sob Cargas Uniformemente Distribuídas**

*me*

SÃO PAULO: RUA AQUINOS, 111 - S.P. - CEP 05036-070 - FONE: (011) 861-0833 - FAX: (011) 861-0170 - TELEX (011) 82802 LAFB BR  
Campinas - São José dos Campos - Santos - Bauriú - Araraquara - São José do Rio Preto - Sorocaba - Rio de Janeiro (RJ)  
88 804.10001 - A3048

Ref.: E/45.864/95  
 Fls.: 05/06

**l.a.falcão bauer**  
 centro tecnológico de controle da qualidade

PRESSÃO (Pa)	VELOCIDADE DE VENTO CORRESPONDENTE (km/h)	DEFORMAÇÃO (mm)
400	91	4,1
0	-	0,4
800	128	7,9
0	-	0,5
1000	144	9,6
0	-	0,6
1200	157	11,4
0	-	0,6
1400	170	13,1
0	-	0,7
1500	176	14,0
0	-	0,7
1600 *	182	15,0
0	-	0,8
Limite máximo EB 1968 (vão/150)		14,5

(\*) Pressão aplicada a pedido do interessado.  
 O deflectômetro para medida das deformações foi posicionado no montante central da folha interna, no centro do vão.

3.3.1 - De acordo com a EB 1968:

A porta, quando submetida à pressão de ensaio eg tabelada, em função da região de utilização, não deverá:

- a) Apresentar ruptura, colapso total ou parcial de qualquer componente.

SÃO PAULO: RUA AQUINOS, 111 - S.P. - CEP 05036-070 - FONE: (011) 861-0833 - FAX: (011) 861-0170 - TELEX (011) 82802 LAFB BR  
 Campinas - São José dos Campos - Santos - Bauri - Araçatuba - São José do Rio Preto - Sorocaba - Rio de Janeiro (RJ)

Ref.: E/45.864/95  
 Fls.: 06/06

**l.a.falcão bauer**  
 centro tecnológico de controle da qualidade

- b) Apresentar deflexão máxima superior a 1/150 do vão, ou 30 mm, em qualquer de seus perfis.
- c) Ter deterioradas as suas operações de manu - seio.

O protótipo não sofreu danos. As deformações se apresentaram satisfatórias até a pressão 1540 Pa. Encontra-se anexo, gráfico Pressão x Deformação.

4. OBSERVAÇÕES

4.1 - É PARTE INTEGRANTE DESTA RELATÓRIO E O COMPLEMENTA, O DESENHO Nº PC 000202, VÁLIDO COM CARIMBO E RUBRICA DESTA LABORATÓRIO.

As fotos nºs.: 01 a 12 ilustram também o material ensaiado.

4.2 - Nos ensaios de Penetração de Ar e Estanqueidade à Água, o protótipo atendeu as exigências da EB 1968 até a Região V.

4.3 - No ensaio de Comportamento sob Cargas Uniformemente Distribuídas, o desempenho foi satisfatório até a pressão 1540 Pa (v = 178 km/h).

5. Ensaio realizado em 11/09/95.

NOTA IMPORTANTE

Os resultados têm significação restrita, aplicando-se ao somente às amostras ensaiadas.

**L. A. FALCÃO BAUER LTDA.**  
 Centro Tecnológico de Controle da Qualidade  
 LICIA ALVES E SILVA  
 Eng. Civil - CREA nº 61283/D

São Paulo, 19 de Setembro de 1995.

**L. A. FALCÃO BAUER LTDA.**  
 Centro Tecnológico de Controle da Qualidade  
 VERA L. FALCÃO BAUER LOURENÇO  
 Eng. Civil - CREA nº 42146/D

LAS/ssa.

SÃO PAULO: RUA AQUINOS, 111 - S.P. - CEP 05036-070 - FONE: (011) 861-0833 - FAX: (011) 861-0170 - TELEX (011) 82802 LAFB BR  
 Campinas - São José dos Campos - Santos - Bauri - Araçatuba - São José do Rio Preto - Sorocaba - Rio de Janeiro (RJ)

ANEXO E/45.864/95  
 Fls.: 01/08

**l.a.falcão bauer**  
 centro tecnológico de controle da qualidade

ANEXOS AO RELATÓRIO E/45.864/95

- Desenho nº PC 000202, com carimbo e rubrica deste laboratório.
- Documentação Fotográfica (fotos nºs.: 01 a 12).
- Gráfico Pressão x Deformação.

SÃO PAULO: RUA AQUINOS, 111 - S.P. - CEP 05036-070 - FONE: (011) 861-0833 - FAX: (011) 861-0170 - TELEX (011) 82802 LAFB BR  
 Campinas - São José dos Campos - Santos - Bauri - Araçatuba - São José do Rio Preto - Sorocaba - Rio de Janeiro (RJ)

ANEXO E/45.864/95  
 Fls.: 02/08  
**l.a.falcão bauer**  
 centro tecnológico de controle da qualidade

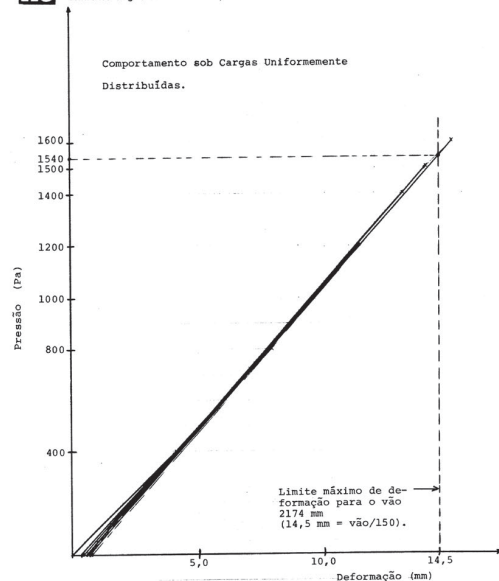

INTERESSADO:  
 OBRA:  
 RELATÓRIO Nº:  
 CP Nº

ANEXO E/45.864/95  
 Fls.: 03/08

**l.a.falcão bauer**  
 centro tecnológico de controle da qualidade



Foto nº 01  
 Teste de Penetração de Ar  
 - 1ª fase -



Foto nº 02  
 Teste de Estanqueidade  
 à Água.

SÃO PAULO: RUA AQUINOS, 111 - S.P. - CEP 05036-070 - FONE: (011) 861-0833 - FAX: (011) 861-0170 - TELEX (011) 82802 LAFB BR  
 Campinas - São José dos Campos - Santos - Bauriú - Araraquara - São José do Rio Preto - Sorocaba - Rio de Janeiro (RJ)  
 50 Bn. 1004 - AGNS

ANEXO Ref.: E/45.864/95  
 Fls.: 04/08

**l.a.falcão bauer**  
 centro tecnológico de controle da qualidade



Foto nº 03  
 Teste de Estanqueidade à  
 Água.





Foto nº 04  
 Detalhe do montante  
 central da folha inter-  
 na.

SÃO PAULO: RUA AQUINOS, 111 - S.P. - CEP 05036-070 - FONE: (011) 861-0833 - FAX: (011) 861-0170 - TELEX (011) 82802 LAFB BR  
 Campinas - São José dos Campos - Santos - Bauriú - Araraquara - São José do Rio Preto - Sorocaba - Rio de Janeiro (RJ)  
 50 Bn. 1004 - AGNS

ANEXO E/45.864/95  
 Fls.: 05/08

**l.a.falcão bauer**  
 centro tecnológico de controle da qualidade



Fotos nºs 05 e 06  
 Posição do deflectômetro  
 para medida das deformações.

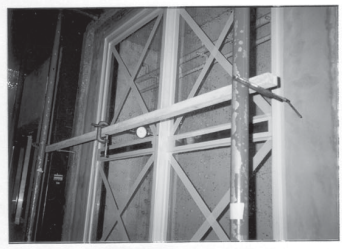

SÃO PAULO: RUA AQUINOS, 111 - S.P. - CEP 05036-070 - FONE: (011) 861-0833 - FAX: (011) 861-0170 - TELEX (011) 82802 LAFB BR  
 Campinas - São José dos Campos - Santos - Bauriú - Araraquara - São José do Rio Preto - Sorocaba - Rio de Janeiro (RJ)  
 50 Bn. 1004 - AGNS

ANEXO E/45.864/95  
 Fls.: 06/08

**l.a.falcão bauer**  
 centro tecnológico de controle da qualidade



Fotos nºs. 07 e 08  
 Vista externa.



SÃO PAULO: RUA AQUINOS, 111 - S.P. - CEP 05036-070 - FONE: (011) 861-0833 - FAX: (011) 861-0170 - TELEX (011) 82802 LAFB BR  
 Campinas - São José dos Campos - Santos - Bauriú - Araraquara - São José do Rio Preto - Sorocaba - Rio de Janeiro (RJ)  
 50 Bn. 1004 - AGNS



ANEXO E/45.864/95  
 Fls.: 07/08

**l.a.falcão bauer**  
 centro tecnológico de controle da qualidade



Foto nº 09  
 Vista externa.





Foto nº 10  
 Detalhe do trilho inferior.

SÃO PAULO: RUA AQUINOS, 111 - S.P. - CEP 05035-070 - FONE: (011) 851-0170 - FAX: (011) 851-0170 - TELEX (011) 82502 LAFB BR  
 Campinas - São José dos Campos - Santos - Bauri - Araraquara - São José do Rio Preto - Sorocaba - Rio de Janeiro (RJ)  
 50 Sts. 1504 - AGNE

ANEXO E/45.864/95  
 Fls.: 08/08

**l.a.falcão bauer**  
 centro tecnológico de controle da qualidade



Fotos nºs.: 11 e 12  
 Segmentos de escova nas travessas superior e inferior do marco.



SÃO PAULO: RUA AQUINOS, 111 - S.P. - CEP 05035-070 - FONE: (011) 851-0170 - FAX: (011) 851-0170 - TELEX (011) 82502 LAFB BR  
 Campinas - São José dos Campos - Santos - Bauri - Araraquara - São José do Rio Preto - Sorocaba - Rio de Janeiro (RJ)  
 50 Sts. 1504 - AGNE



## Capítulo 3

# Tipología

JANELA 2 FOLHAS

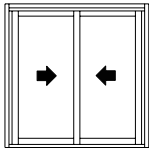

JANELA 3 FOLHAS

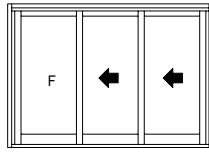

JANELA 4 FOLHAS

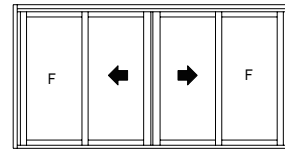

JANELA 2 FOLHAS C/ BANDEIRA MÓVEL

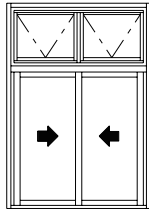

JANELA 4 FOLHAS C/ PEITORIL FIXO

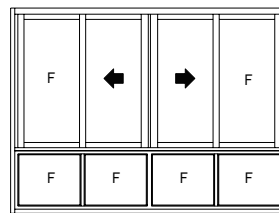

JANELA 3 FOLHAS

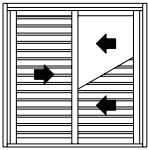

JANELA 4 FOLHAS

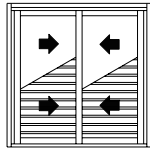

JANELA CAMARÃO

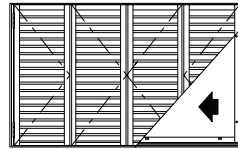

JANELA 6 FOLHAS

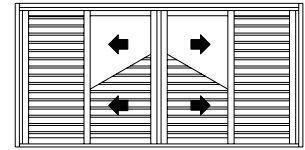

PORTA 3 FOLHAS

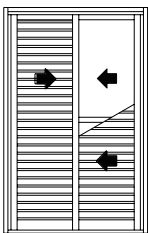

PORTA 2 FOLHAS

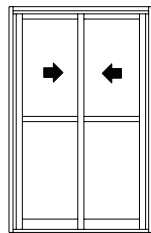

PORTA 4 FOLHAS

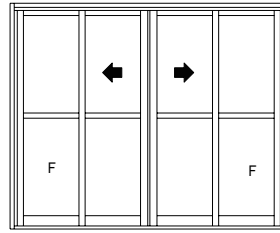

PORTA 3 FOLHAS

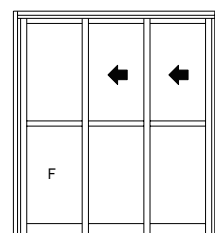

JANELA MAXIM-AR 1 FOLHA

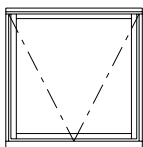

JANELA MAXIM-AR 2 FOLHAS

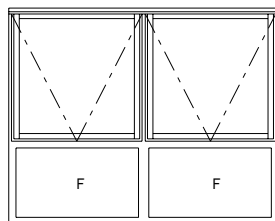

PORTA 1 FOLHAS

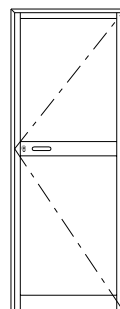

PORTA 2 FOLHAS

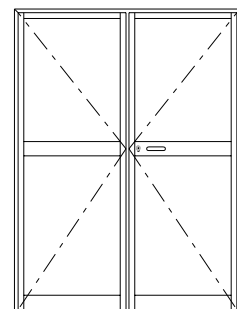



## Capítulo 4

# Diagramas de dimensões



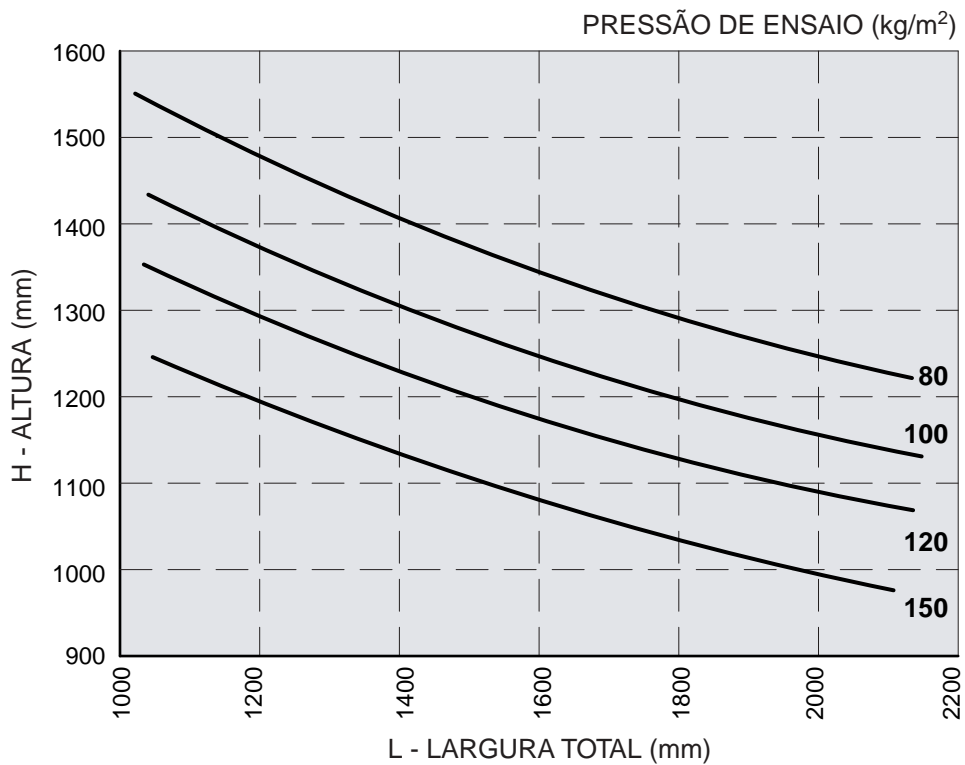
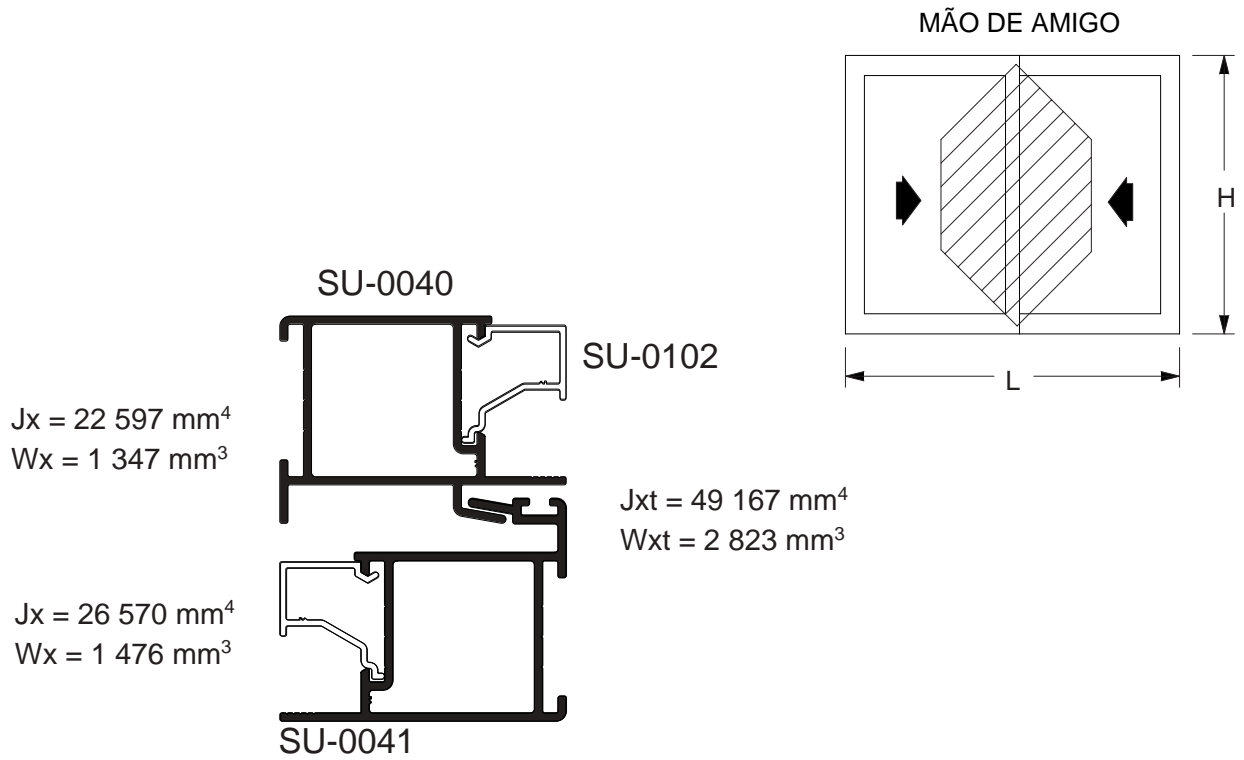

CENTRAL 4 FOLHAS

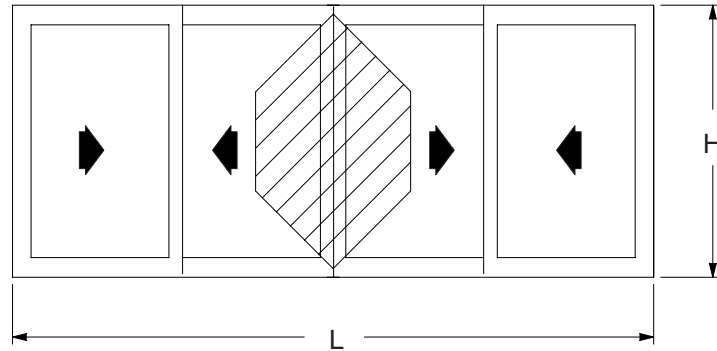

$J_{xt} = 53\,423\text{ mm}^4$   
 $W_{xt} = 3\,951\text{ mm}^3$

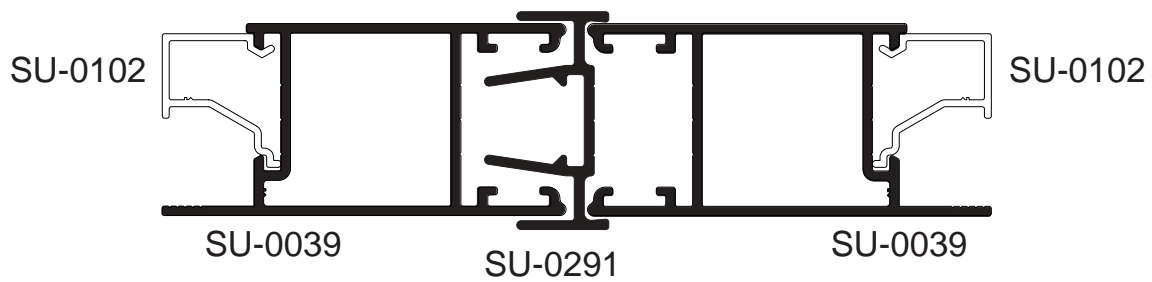

SU-0039/0102

$J_x = 22\,473\text{ mm}^4$   
 $W_x = 1\,791\text{ mm}^3$

SU-0039/0291/0102

$J_x = 30\,950\text{ mm}^4$   
 $W_x = 2\,160\text{ mm}^3$

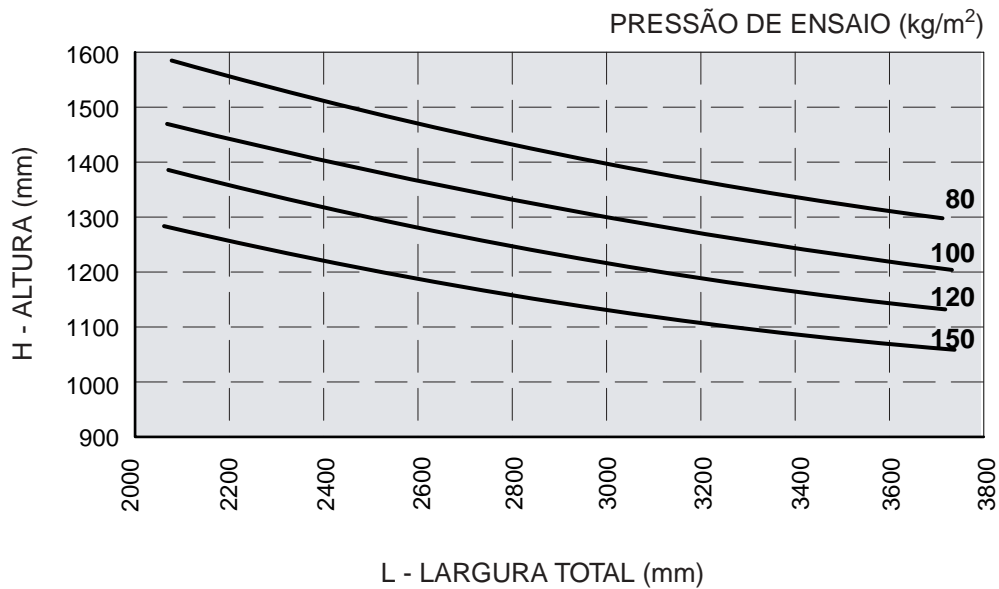

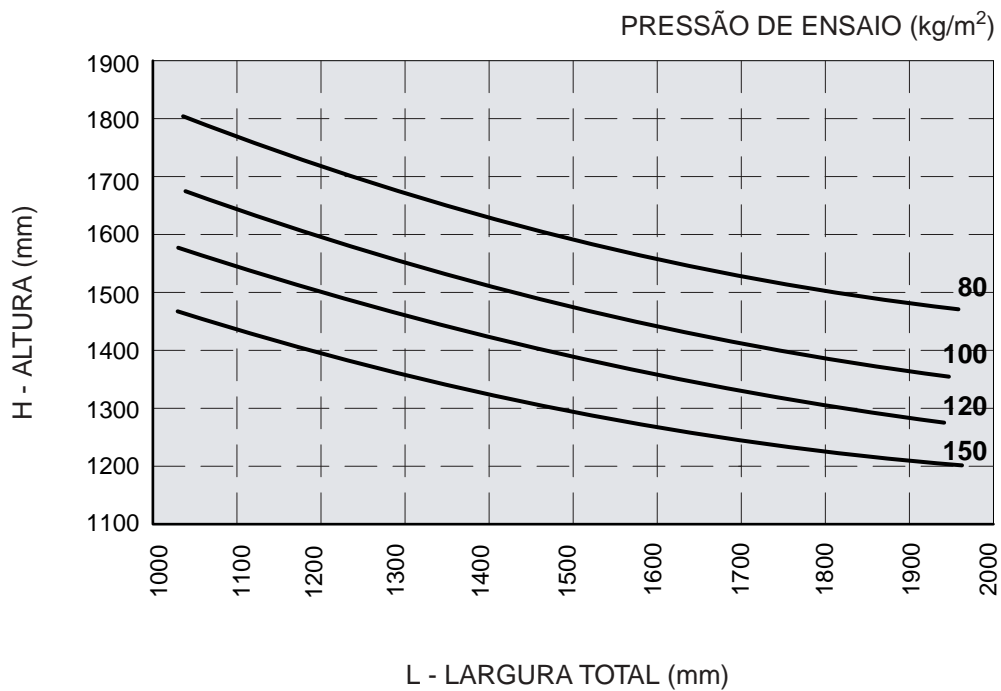
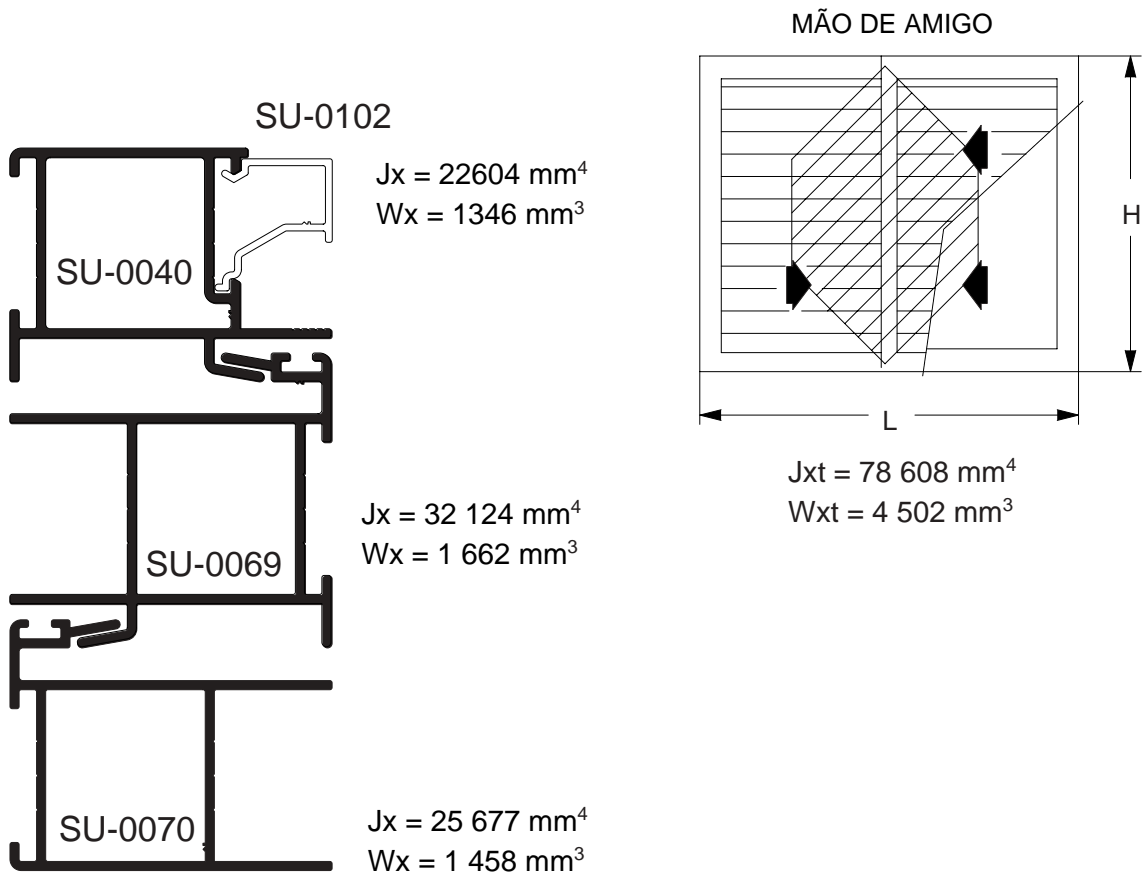

MÃO DE AMIGO

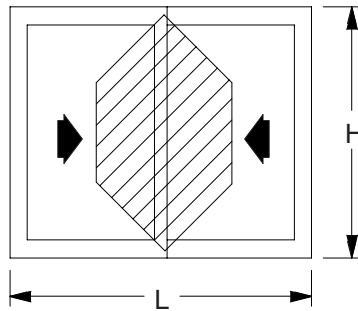

$$Jx = 22604 \text{ mm}^4$$

$$Wx = 1346 \text{ mm}^3$$

MÃO DE AMIGO

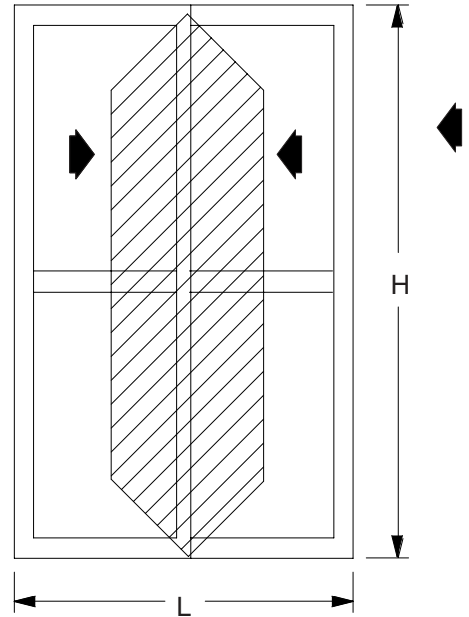

$$Jxt = 259\,283 \text{ mm}^4$$

$$Wxt = 7\,884 \text{ mm}^3$$

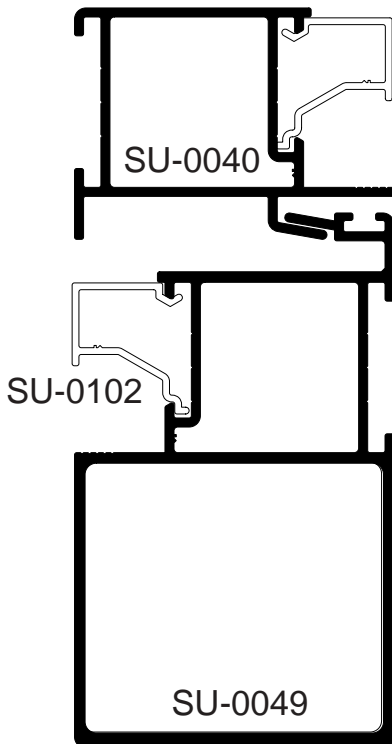

PRESSÃO DE ENSAIO (kg/m<sup>2</sup>)

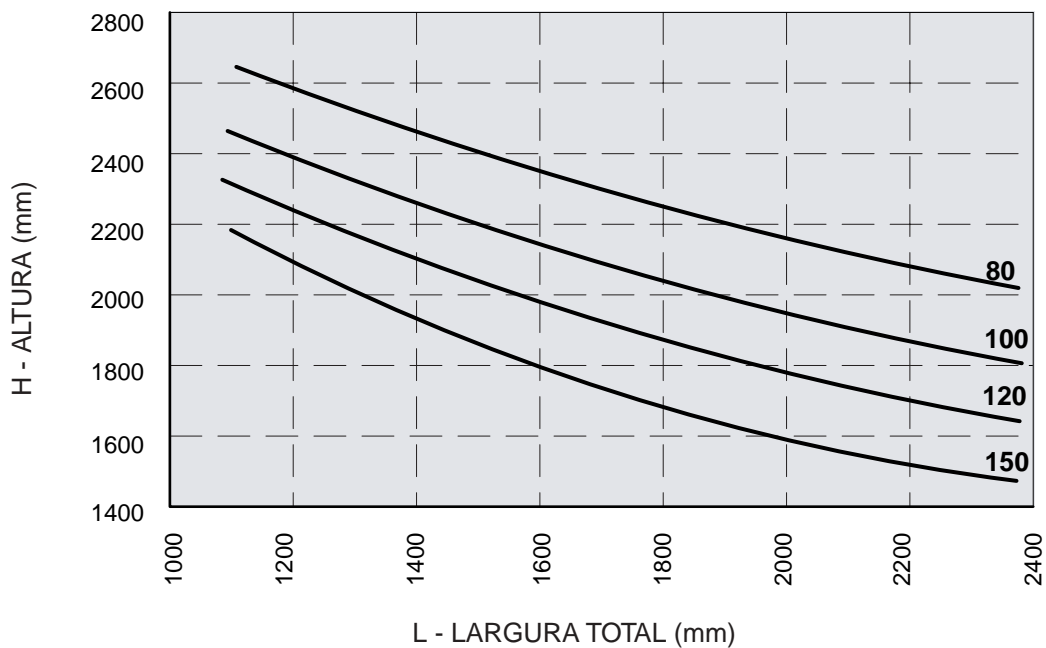



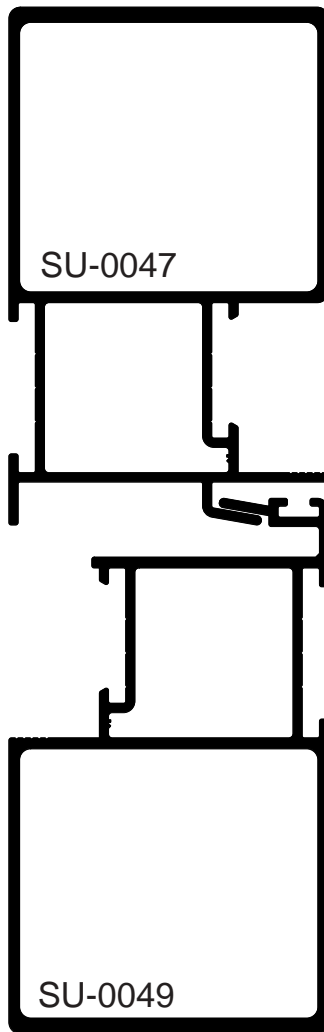

$J_x = 207\ 351\ \text{mm}^4$   
 $W_x = 5\ 675\ \text{mm}^3$

$J_x = 217\ 149\ \text{mm}^4$   
 $W_x = 5\ 565\ \text{mm}^3$

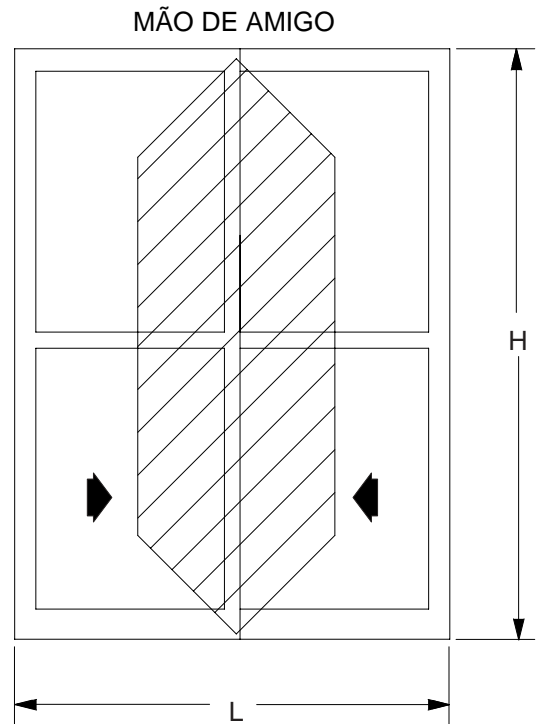

$J_{xt} = 424\ 500\ \text{mm}^4$   
 $W_{xt} = 11\ 240\ \text{mm}^3$

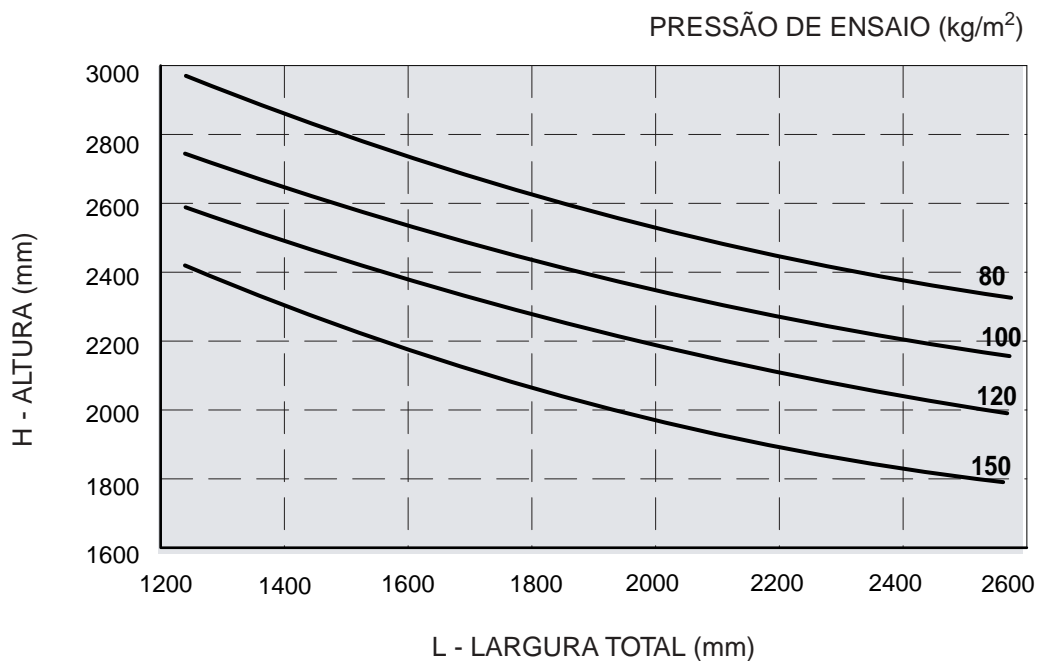

OBS.: Não ultrapassar 70kg por folha.

## CENTRAL 4 FOLHAS

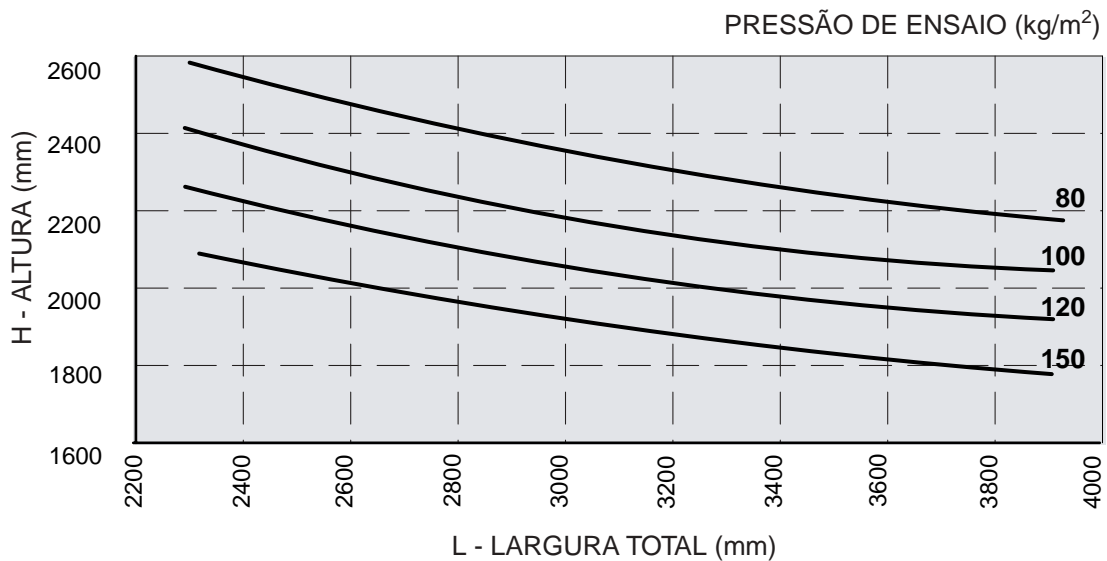
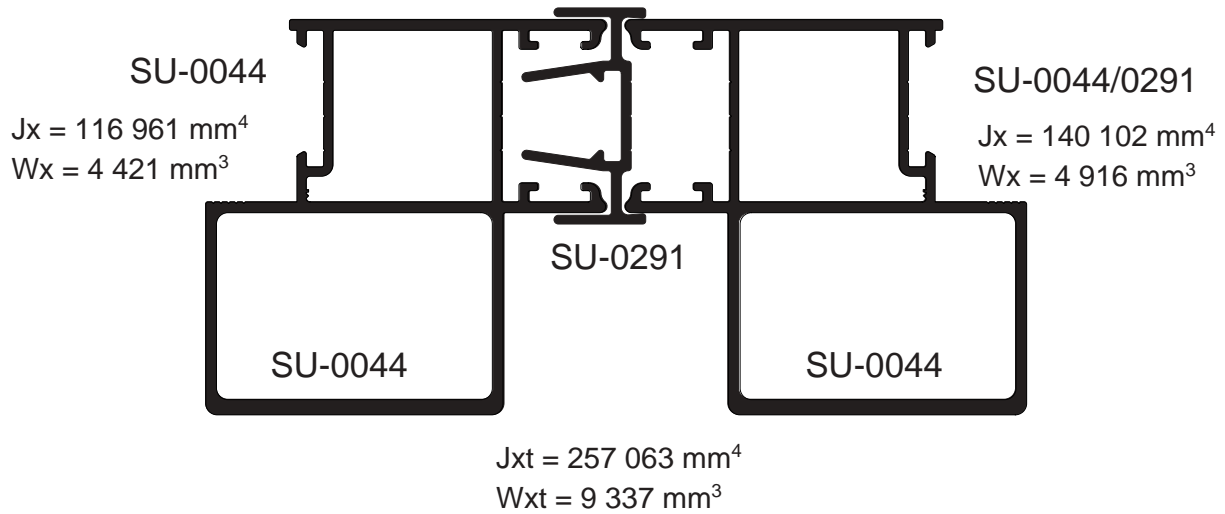
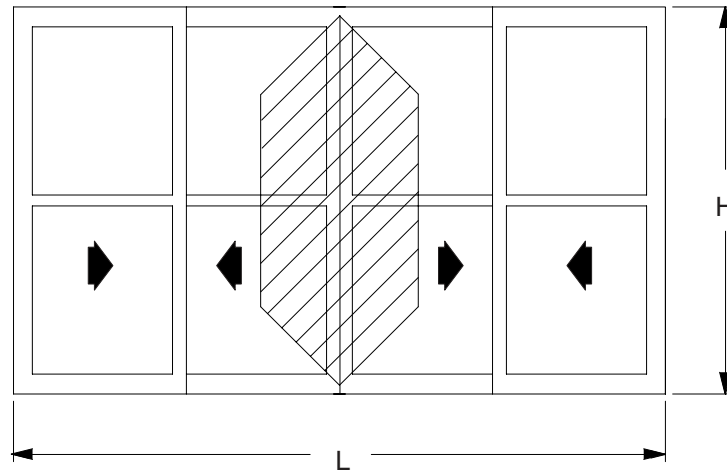

OBS.: Não ultrapassar 70kg por folha.

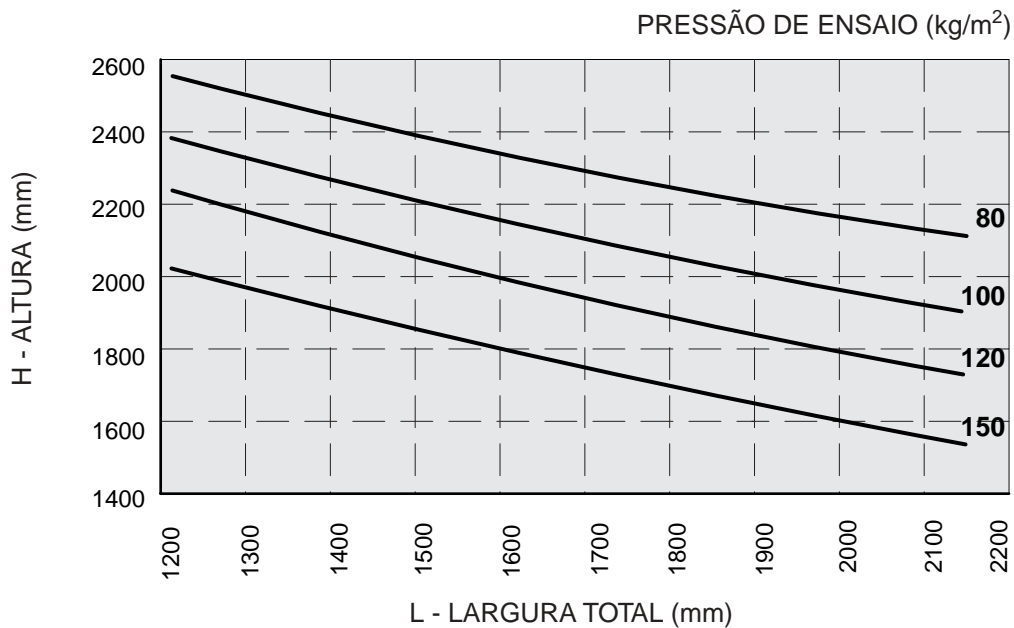
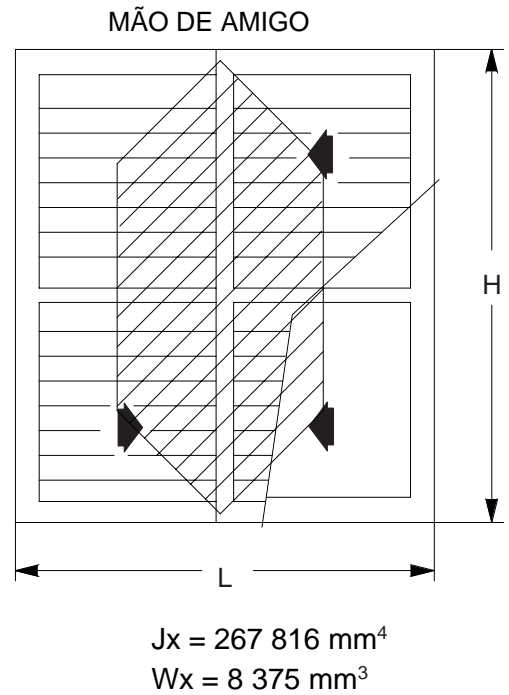
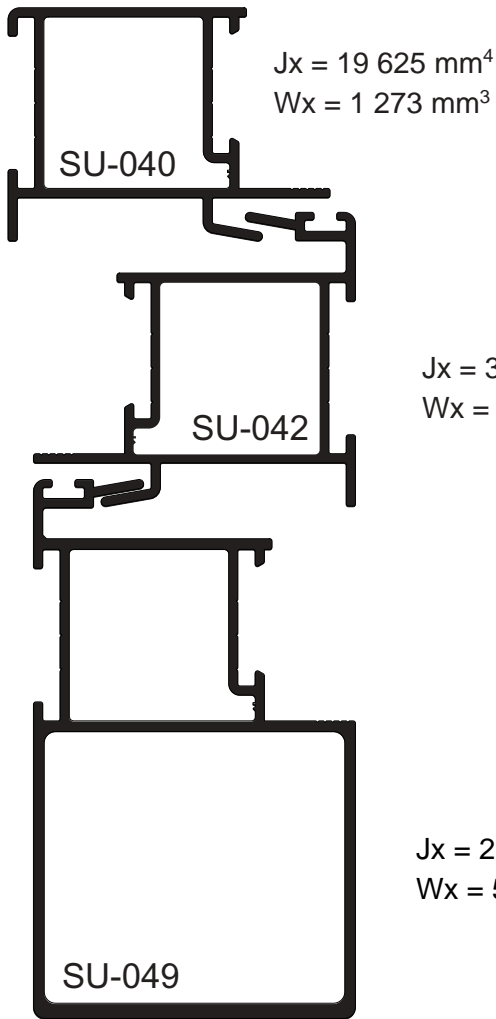

OBS.: Não ultrapassar 70kg por folha.

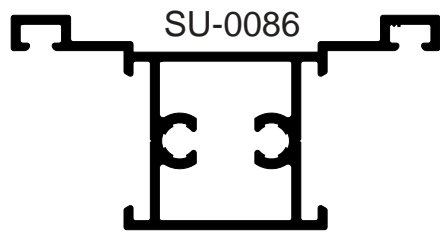

$J_x = 19\,917\text{ mm}^4$   
 $W_x = 1\,271\text{ mm}^3$

MONTANTE MAXIM-AR

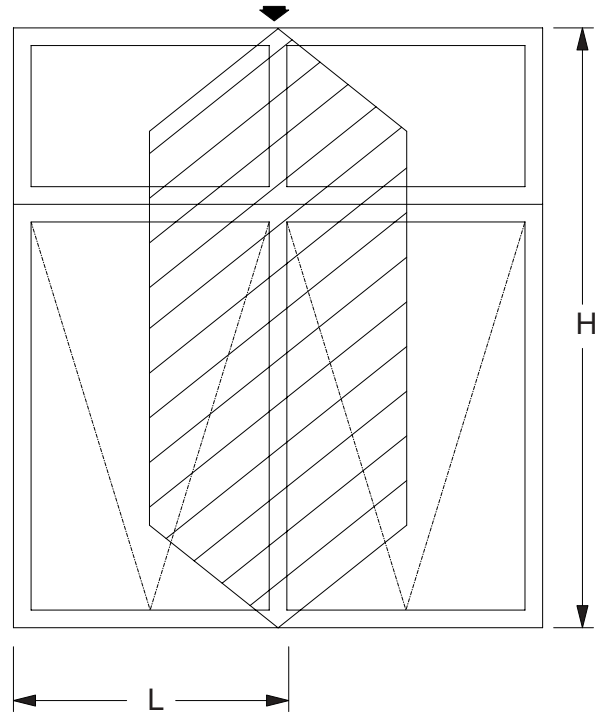

Dimensão máxima da folha móvel 900 x 900mm

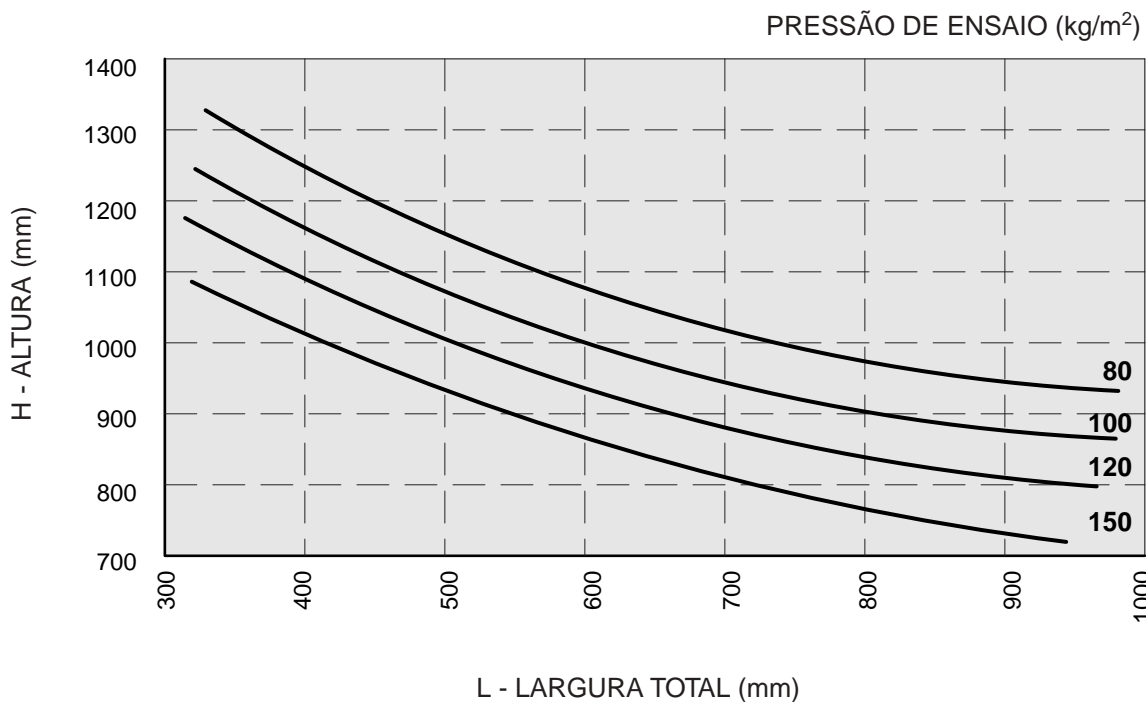



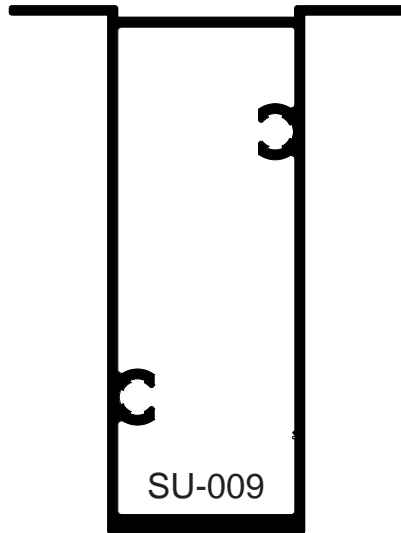

$J_x = 218\,490 \text{ mm}^4$   
 $W_x = 6\,217 \text{ mm}^3$

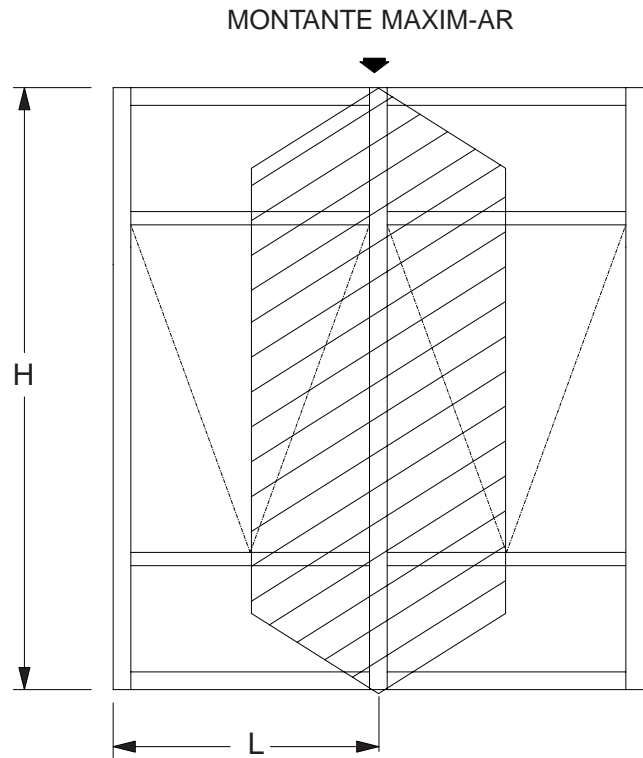

Dimensão máxima da folha móvel 900 x 900mm

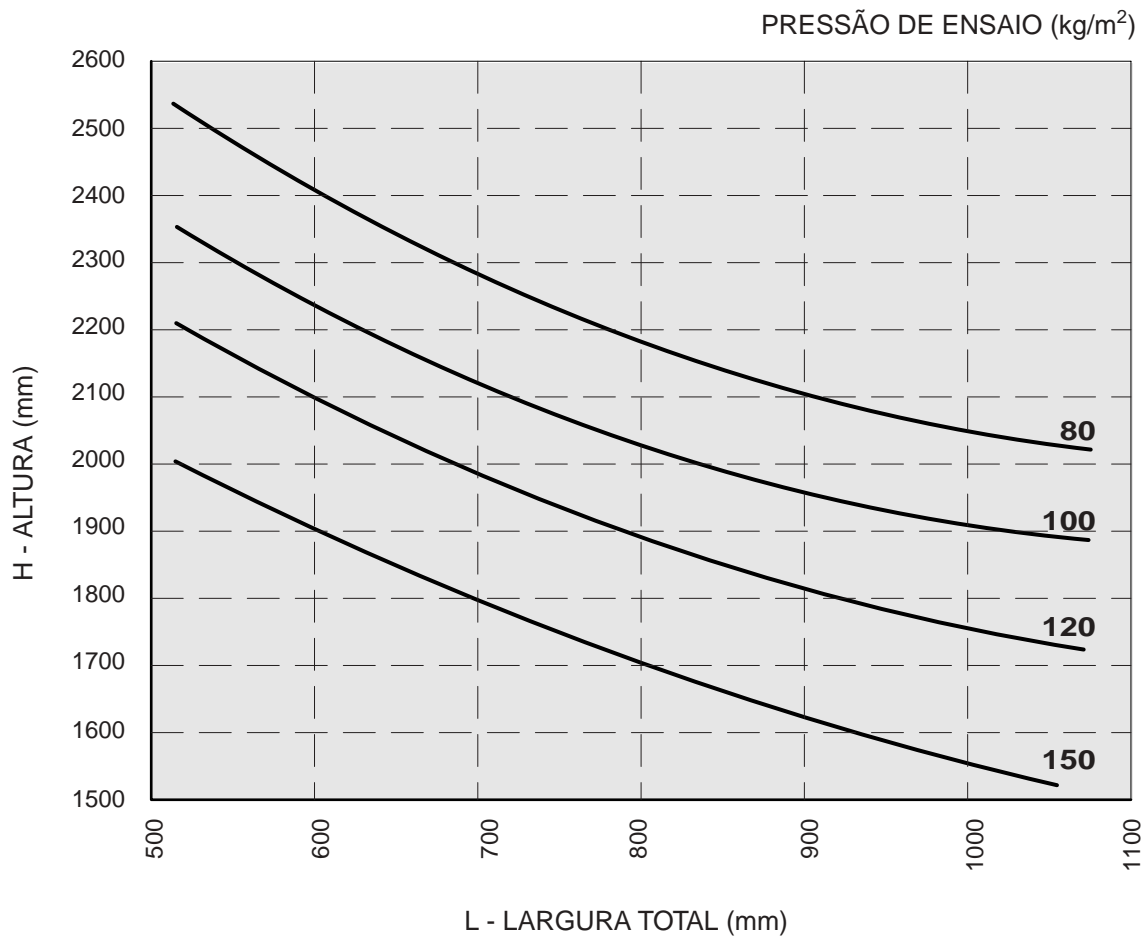

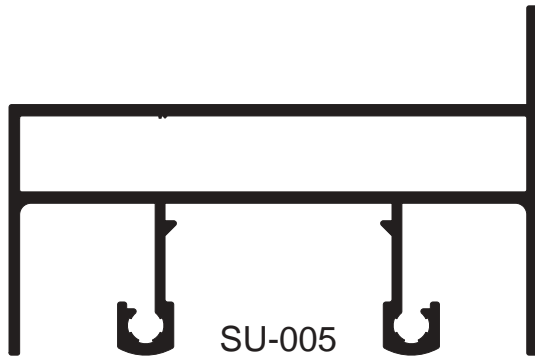

$J_y = 230\,487\text{ mm}^4$   
 $W_y = 6\,320\text{ mm}^3$

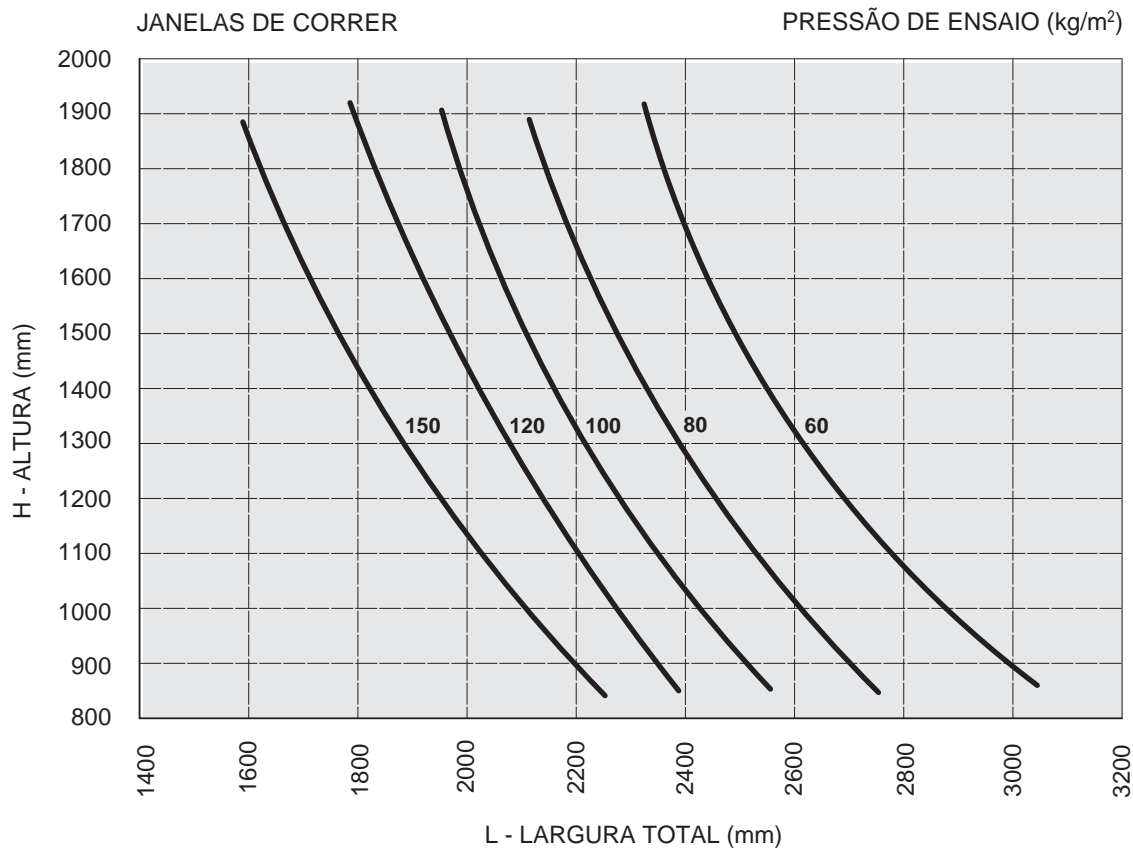
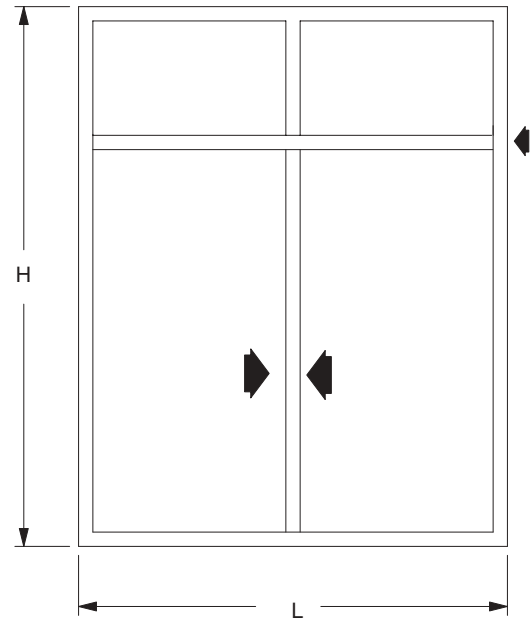

## PEITORIL

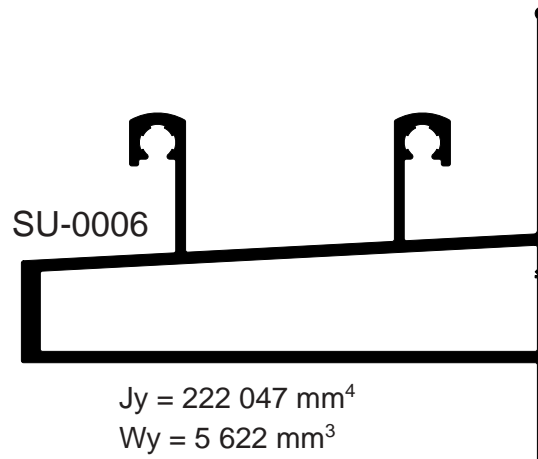
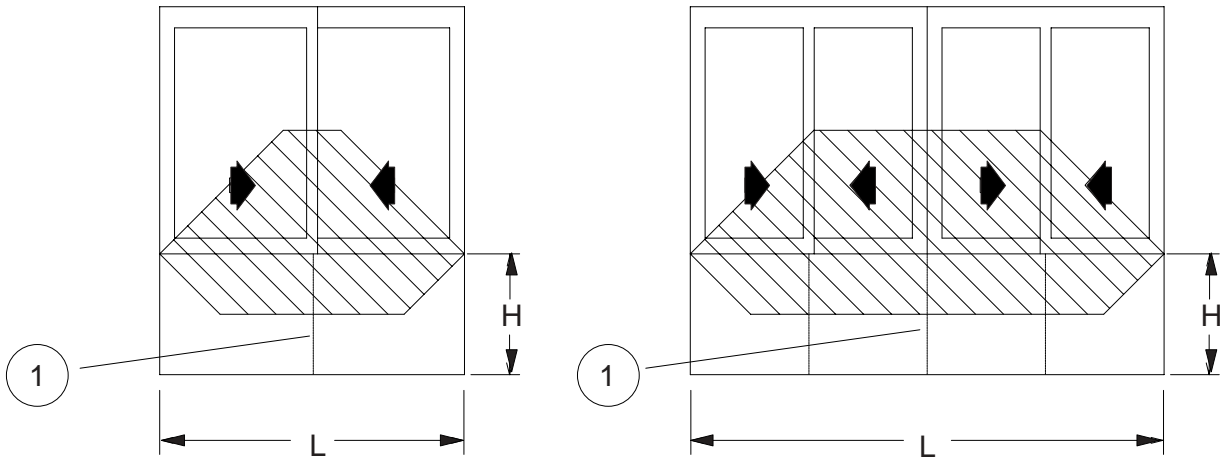

PRESSÃO DE ENSAIO (kg/m<sup>2</sup>)

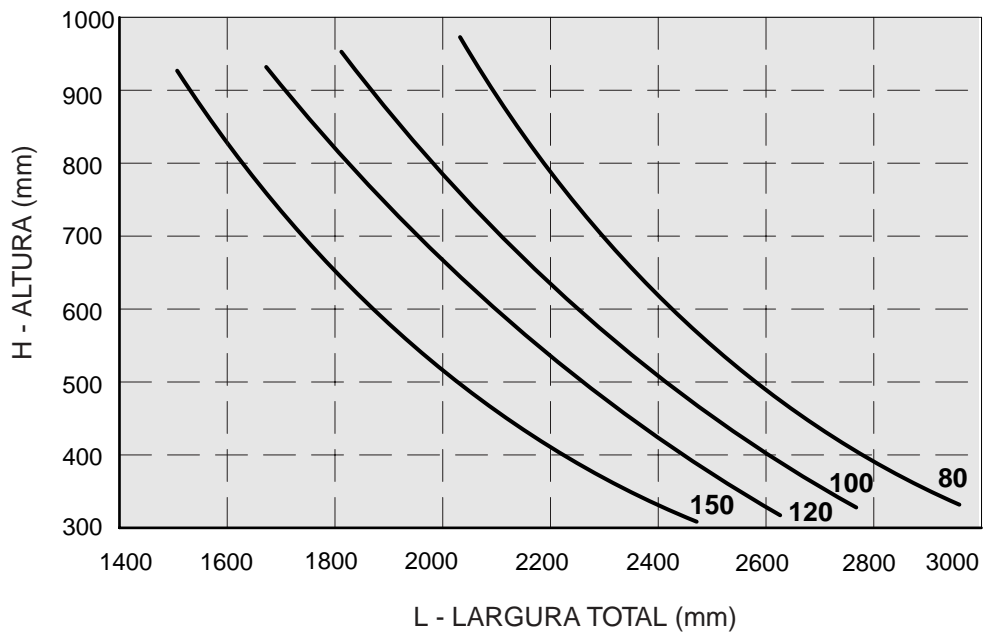

1 Recomendável o uso de montantes para L acima de 1600mm

CENTRAL 4 FOLHAS

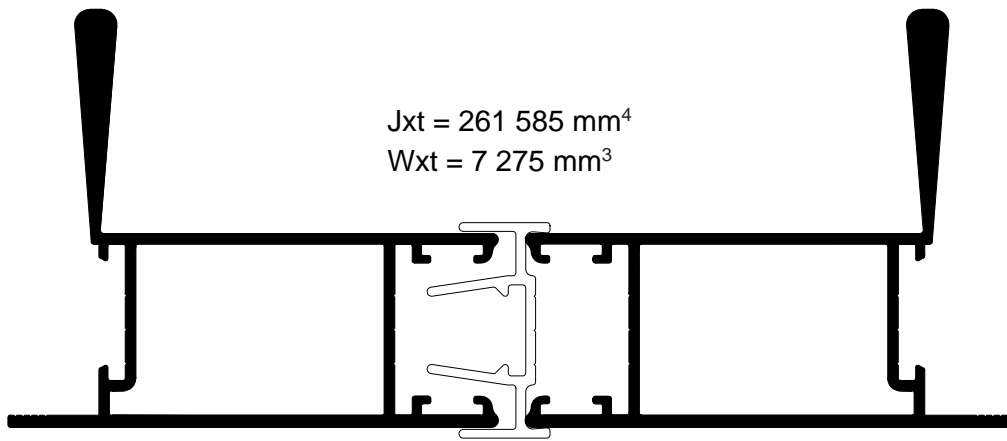
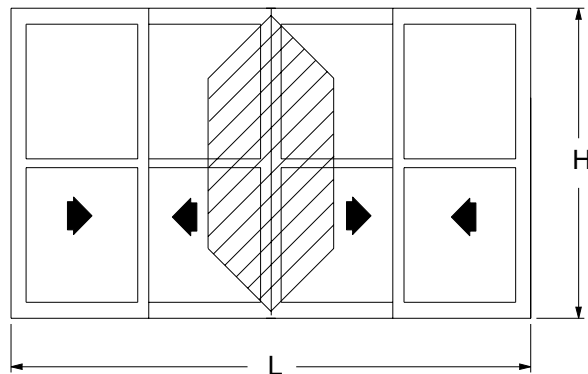

SU-0280

$J_x = 112\,834\text{ mm}^4$   
 $W_x = 3\,249\text{ mm}^3$

SU-0291

SU-0280/0291

$J_x = 148\,751\text{ mm}^4$   
 $W_x = 4\,026\text{ mm}^3$

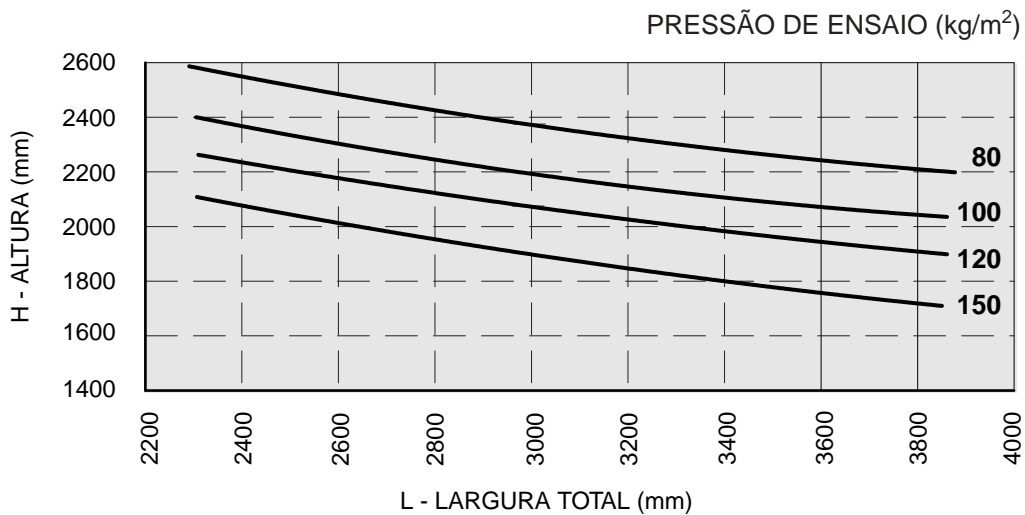

OBS.: Não ultrapassar 70kg por folha.



MÃO DE AMIGO

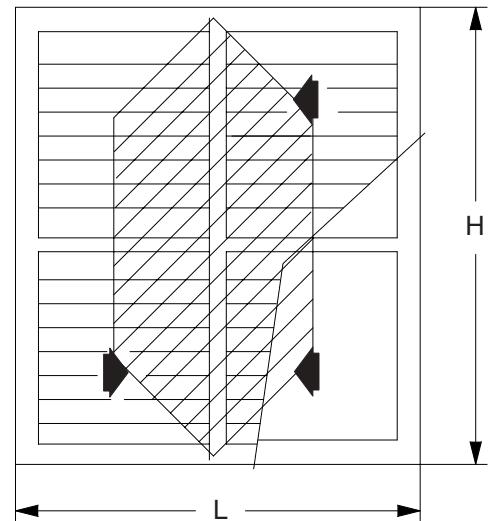

$$J_{xt} = 455\,542 \text{ mm}^4$$

$$W_{xt} = 12\,777 \text{ mm}^3$$

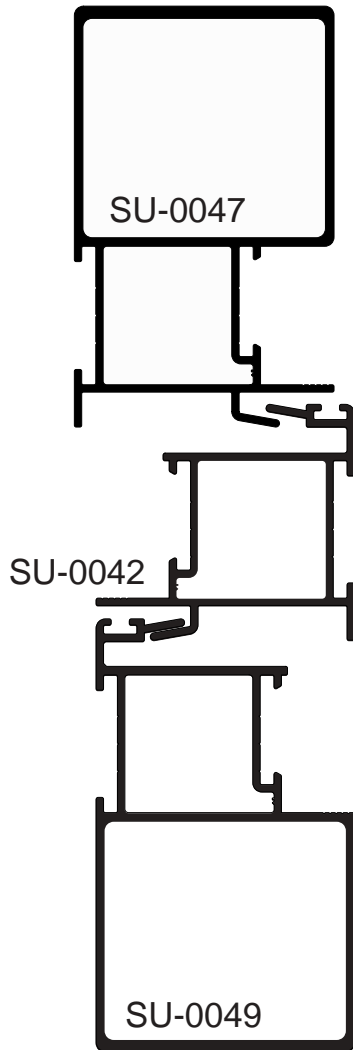

$$J_x = 207\,351 \text{ mm}^4$$

$$W_x = 5\,675 \text{ mm}^3$$

$$J_x = 31\,042 \text{ mm}^4$$

$$W_x = 1\,537 \text{ mm}^3$$

$$J_x = 217\,149 \text{ mm}^4$$

$$W_x = 5\,565 \text{ mm}^3$$

PRESSÃO DE ENSAIO (kg/m<sup>2</sup>)

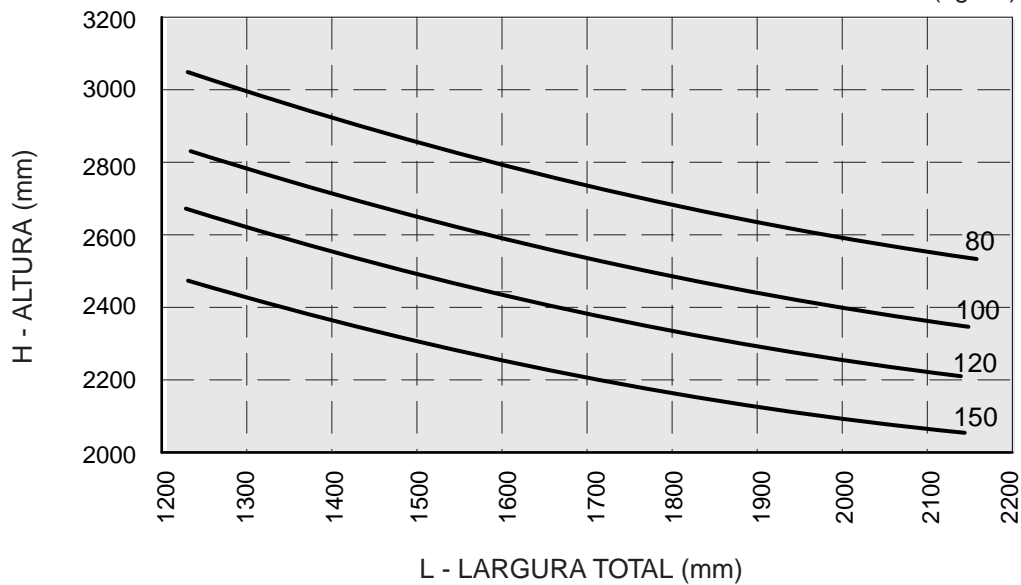

OBS.: Não ultrapassar 70kg por folha.

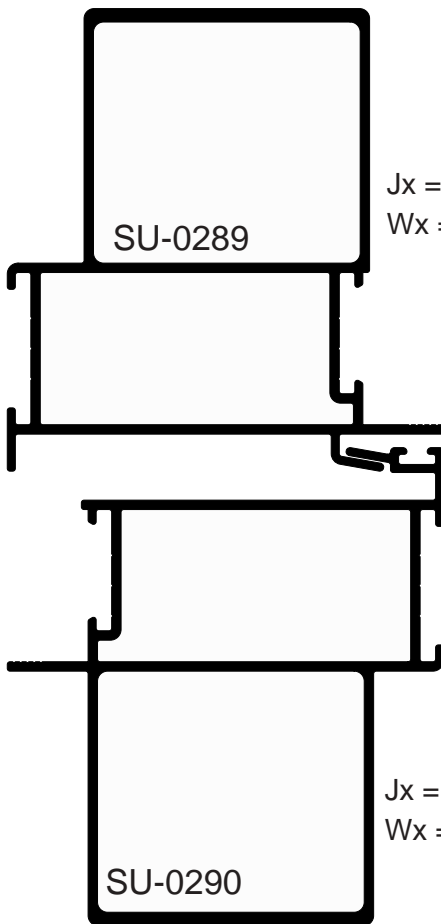

$J_x = 243\,287\text{ mm}^4$   
 $W_x = 6\,862\text{ mm}^3$

$J_x = 246\,126\text{ mm}^4$   
 $W_x = 6\,927\text{ mm}^3$

### MÃO DE AMIGO

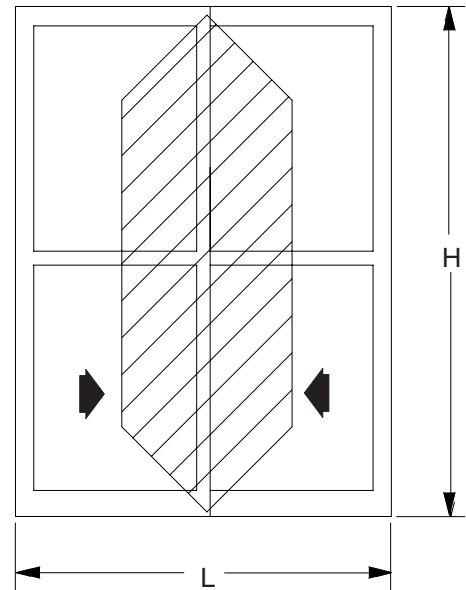

$J_{xt} = 489\,413\text{ mm}^4$   
 $W_{xt} = 13\,789\text{ mm}^3$

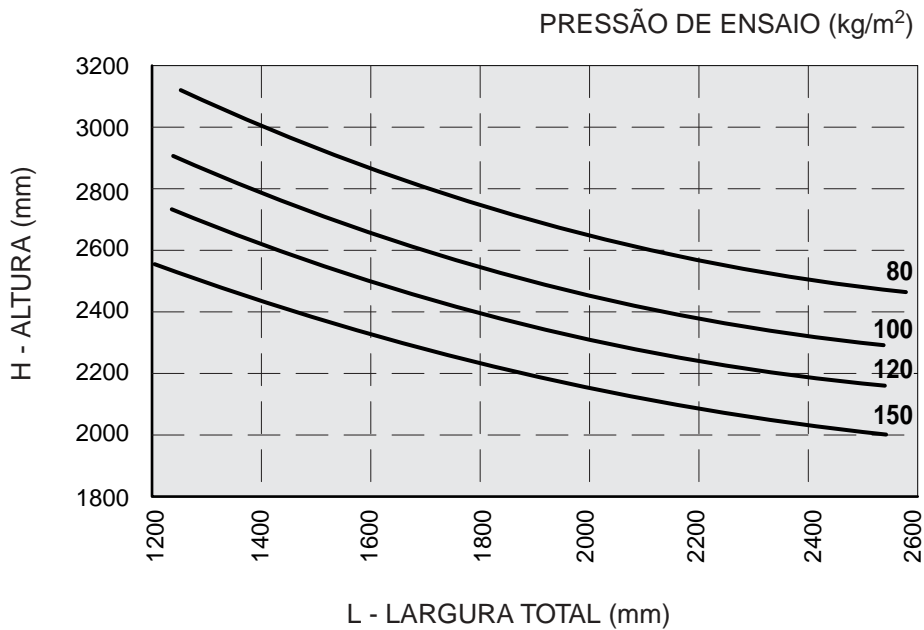

OBS.: Não ultrapassar 70kg por folha.

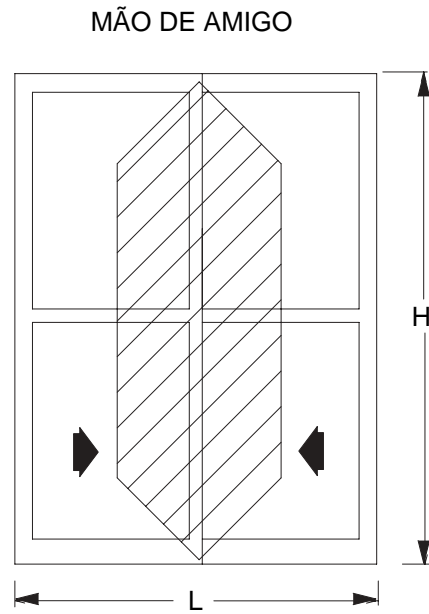
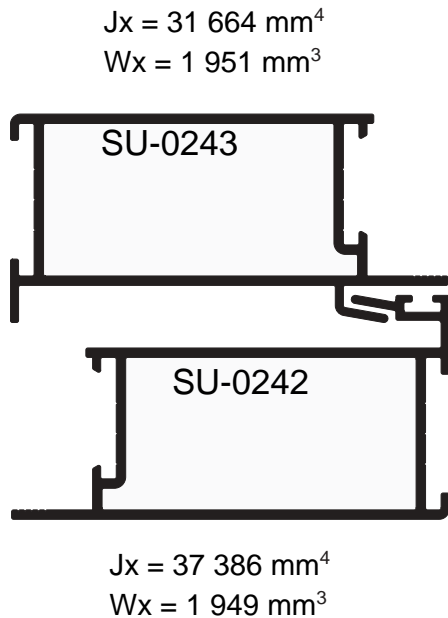

$J_{xt} = 69\ 050\ \text{mm}^4$   
 $W_{xt} = 3\ 900\ \text{mm}^3$

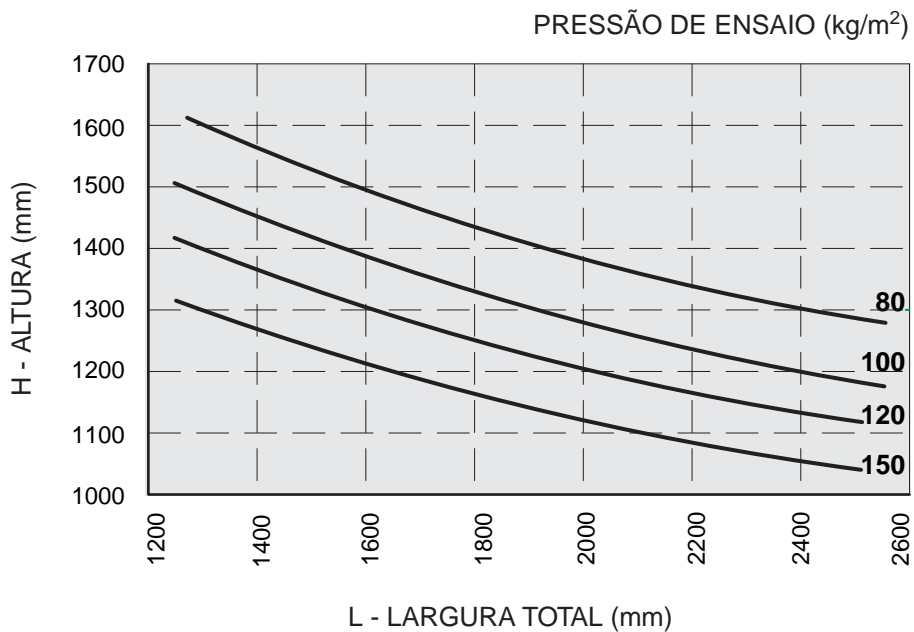

OBS.: Não ultrapassar 70kg por folha.

## CENTRAL 4 FOLHAS

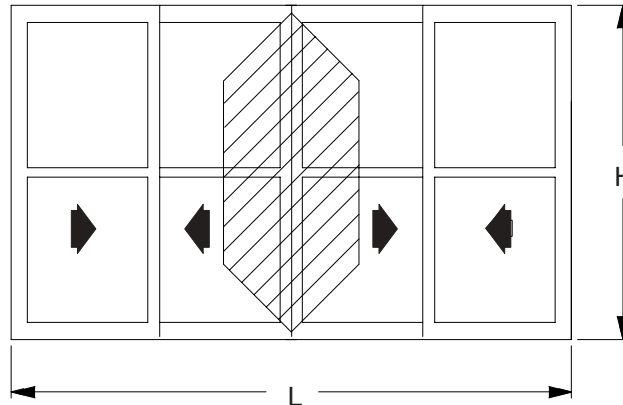

$J_{xt} = 279\,341 \text{ mm}^4$   
 $W_{xt} = 9\,886 \text{ mm}^3$

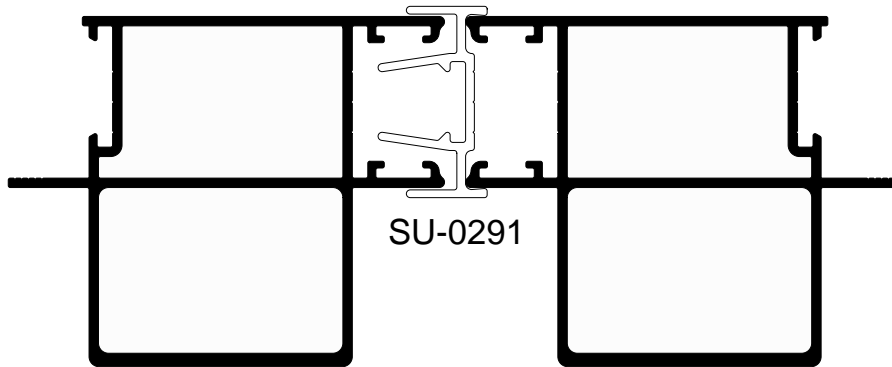

**SU-0273**  
 $J_x = 129\,557 \text{ mm}^4$   
 $W_x = 4\,791 \text{ mm}^3$

**SU-0273/0291**  
 $J_x = 149\,784 \text{ mm}^4$   
 $W_x = 5\,095 \text{ mm}^3$

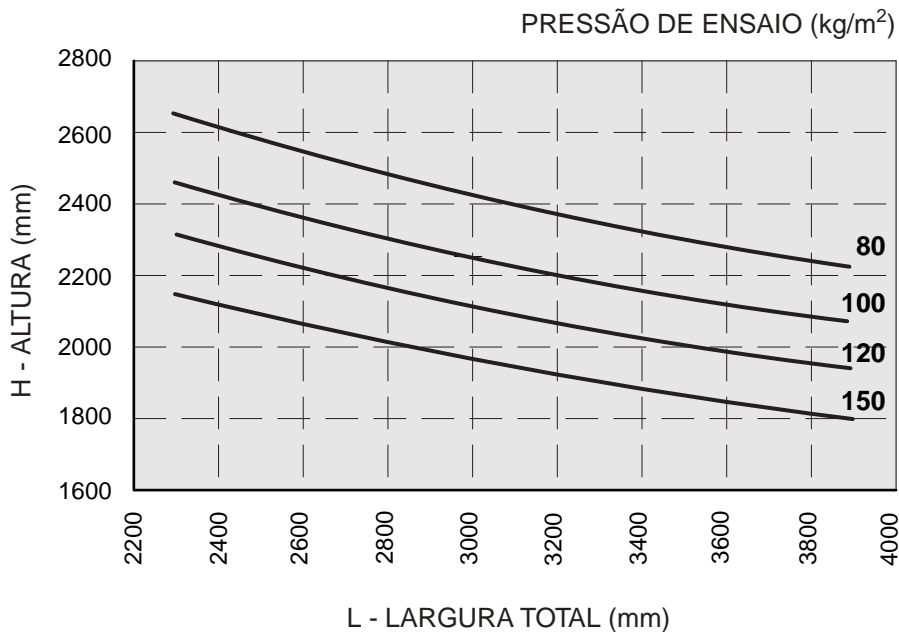

OBS.: Não ultrapassar 70kg por folha.



## Capítulo 5

Perfis

Código	Página
25-548	73
CL-006	44
CL-009	44
CL-010	44
CL-011	44
CM-004	39
CM-006	42
CM-007	42
CM-013	42
CM-014	42
CM-060	40
CM-098	40
CM-099	43
CM-110	40
CM-111	41
CM-113	39
CM-126	39
CM-125	39
CM-130	41
CM-151	40
CM-169	42
CM-175	43
CM-200	40
CX-1226	72
ME-013	42
ME-092	41
MN-014	41
MP-347	41
SU-001	45
SU-002	45
SU-003	45
SU-004	48
SU-005	48
SU-006	48
SU-007	49
SU-009	49
SU-010	50
SU-011	50
SU-012	50
SU-013	51
SU-014	51
SU-018	55
SU-019	51
SU-024	54
SU-025	54

Código	Página
SU-026	46
SU-028	47
SU-029	47
SU-030	47
SU-036	55
SU-039	59
SU-040	59
SU-041	59
SU-042	59
SU-044	58
SU-047	58
SU-049	58
SU-050	61
SU-053	59
SU-055	62
SU-056	62
SU-057	62
SU-058	59
SU-060	64
SU-061	64
SU-068	65
SU-069	65
SU-070	65
SU-071	66
SU-072	66
SU-073	66
SU-074	66
SU-079	69
SU-080	67
SU-081	67
SU-082	67
SU-084	67
SU-085	69
SU-086	69
SU-088	69
SU-090	68
SU-091	68
SU-093	70
SU-094	70
SU-096	70
SU-097	70
SU-098	70
SU-099	71
SU-100	71

Código	Página
SU-101	70
SU-102	71
SU-103	71
SU-107	65
SU-108	71
SU-110	72
SU-111	73
SU-120	72
SU-121	53
SU-122	53
SU-123	53
SU-186	63
SU-187	65
SU-188	63
SU-200	67
SU-203	71
SU-225	61
SU-226	64
SU-227	61
SU-228	56
SU-230	56
SU-238	62
SU-239	63
SU-241	73
SU-242	60
SU-243	60
SU-245	60
SU-250	58
SU-251	46
SU-260	52
SU-271	52
SU-272	52
SU-276	68
SU-279	72
SU-280	60
SU-289	57
SU-290	57
SU-291	49
SU-292	68
TQ-006	61
US-285	74
US-294	74
VZ-006	74
VZ-051	74

● **CM-004**  
 0,304 kg/m  
 Estoque CD  
 TUB ITS  
 ■ □

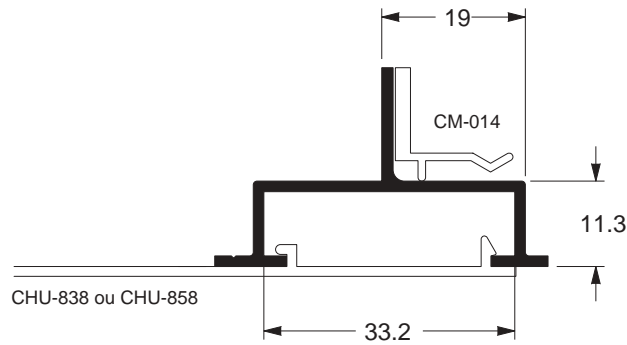

● **CM-126**  
 0,477 kg/m  
 Estoque CD  
 TUB ITS  
 ■ □

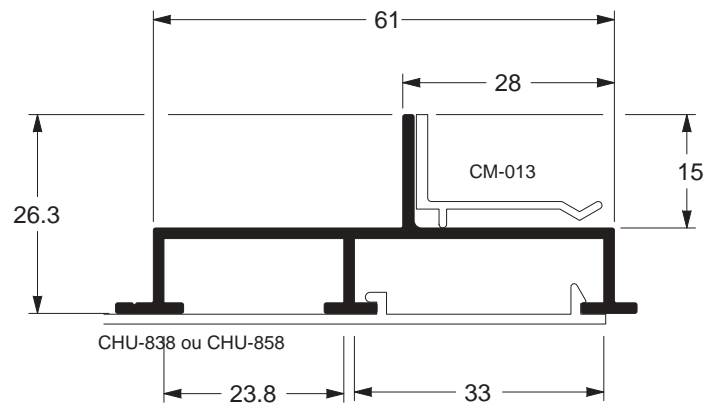

● **CM-125**  
 0,528 kg/m  
 Estoque CD  
 TUB ITS  
 ■ □

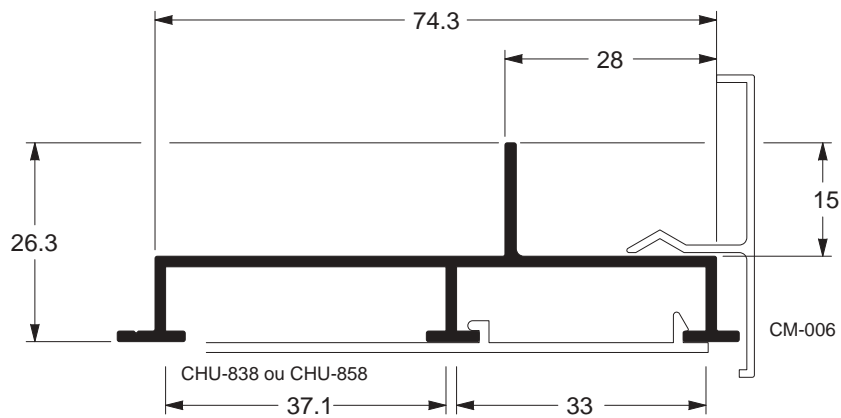

● **CM-113**  
 0,461 kg/m  
 Estoque CD  
 TUB ITS  
 ■ □

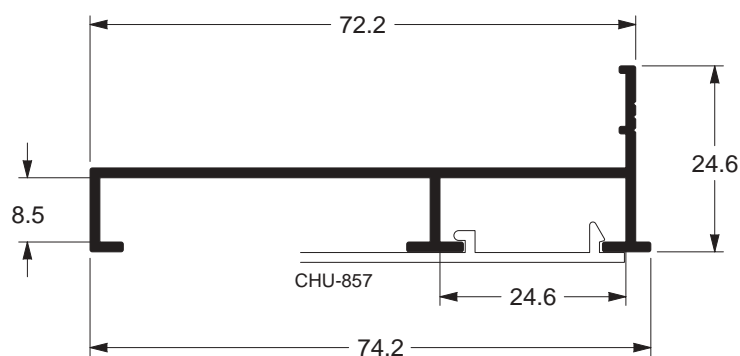

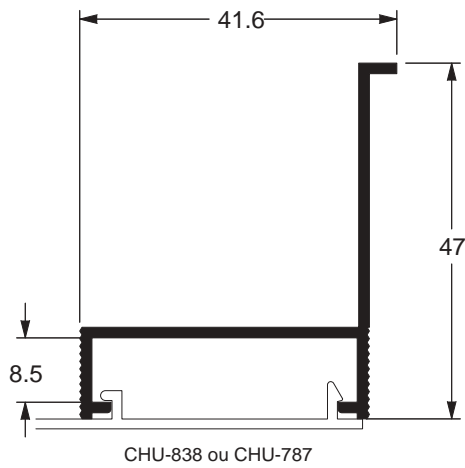

● **CM-098**  
 0,392 kg/m  
 Estoque CD  
 TUB ITS  
 ■ □

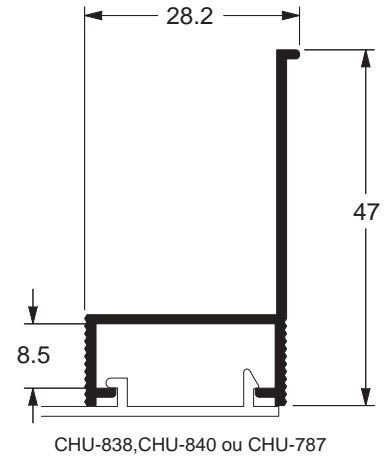

● **CM-151**  
 0,309 kg/m  
 Estoque CD  
 TUB ITS  
 ■ □

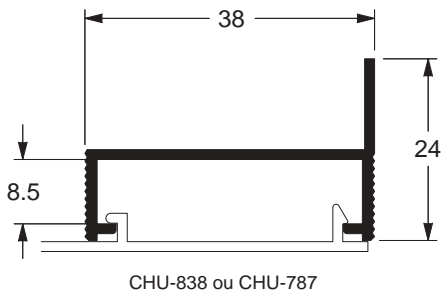

● **CM-060**  
 0,276 kg/m  
 Estoque CD  
 TUB ITS  
 ■ □

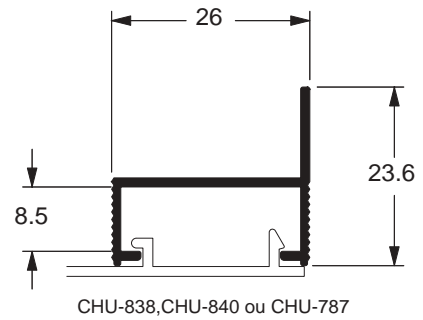

● **CM-200**  
 0,198 kg/m  
 Estoque CD  
 TUB ITS  
 ■ ■

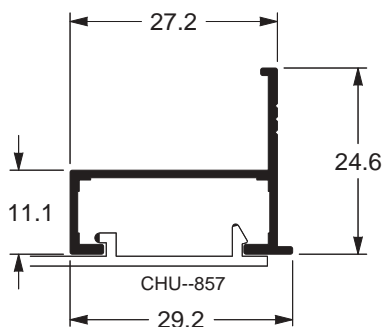

● **CM-110**  
 0,209 kg/m  
 Estoque CD  
 TUB ITS  
 ■ □



Remate / Face interna

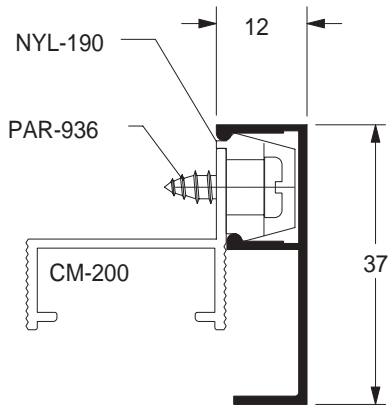

●  
**MP-347**  
 0,202 kg/m  
 Estoque CD  
 TUB ITS  
 ■ ■

Remate / Centro de parede

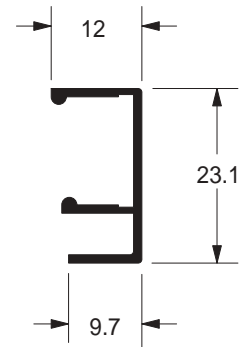

●  
**ME-092**  
 0,160 kg/m  
 Estoque CD  
 TUB ITS  
 ■ □

Remate / Face interna

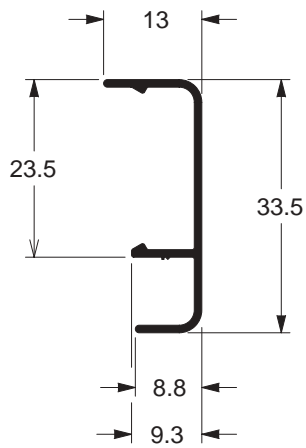

●  
**CM-130**  
 0,166 kg/m  
 Estoque CD  
 TUB ITS  
 ■ □

Remate / Face interna

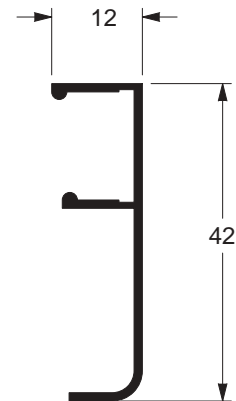

●  
**MN-014**  
 0,214 kg/m  
 Estoque CD  
 TUB ITS  
 ■ □

Remate / Face interna

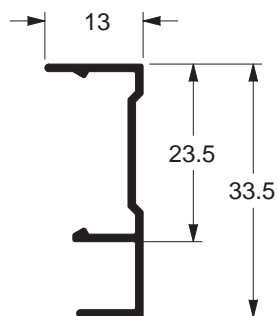

●  
**CM-111**  
 0,173 kg/m  
 Estoque CD  
 TUB ITS  
 ■ □

Remate Piso

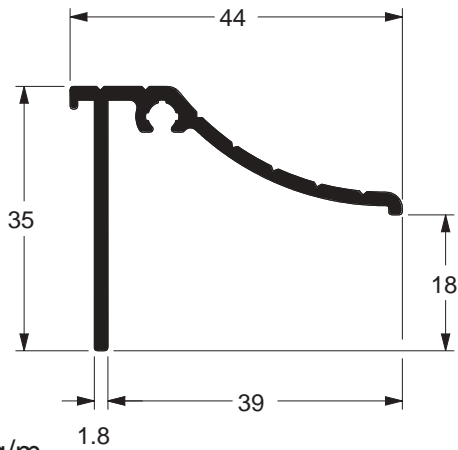

● **CM-169**  
 0,431 kg/m  
 Estoque CD  
 TUB ITS



Remate Piso

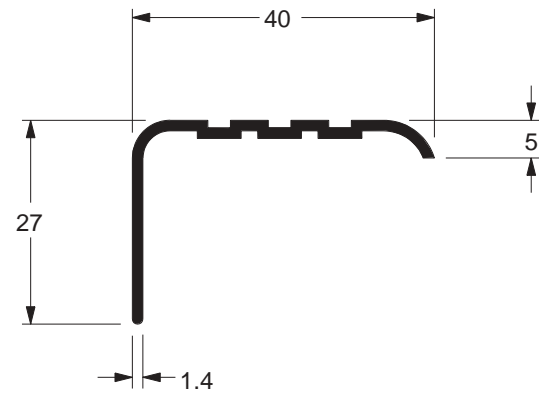

● **ME-013**  
 0,267 kg/m  
 Estoque CD  
 TUB ITS



Remate / Centro de parede

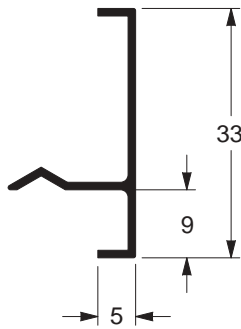

● **CM-007**  
 0,156 kg/m  
 Estoque CD  
 TUB ITS



Remate / Face interna

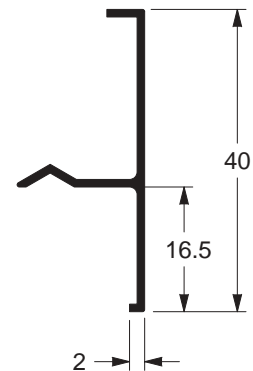

● **CM-006**  
 0,168 kg/m  
 Estoque CD  
 TUB ITS



Presilha

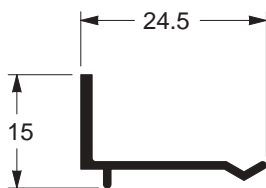

● **CM-013**  
 0,121 kg/m  
 Estoque CD  
 TUB ITS



Presilha

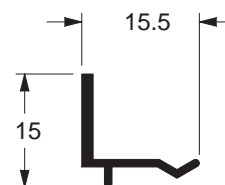

● **CM-014**  
 0,097 kg/m  
 Estoque CD  
 TUB ITS



Chumbador CHU-864

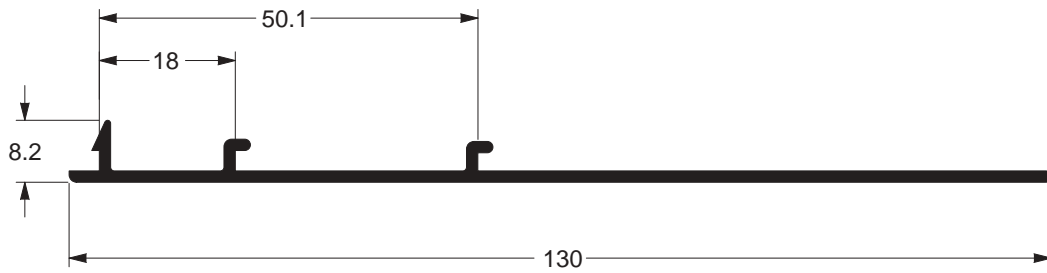

●  
**CM-175**  
 0,602 kg/m  
 Estoque CD  
 TUB ITS  
 ■ ■

Chumbador CHU-840

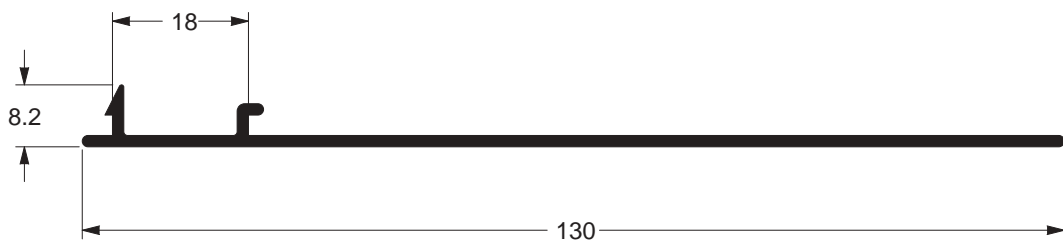

■  
**CM-099**  
 0,577 kg/m  
 Estoque CD  
 TUB ITS  
 ■ □

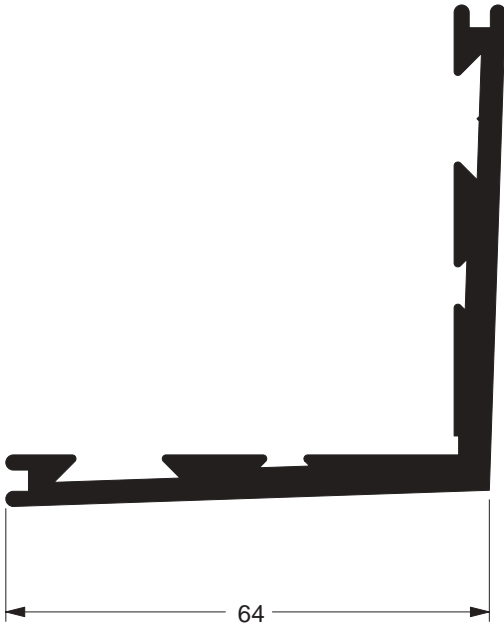

■  
**CL-009**  
 1,616 kg/m  
 Estoque CD  
 TUB ITS  
 ■ ■

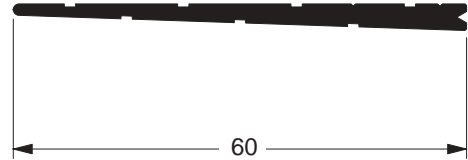

■  
**CL-010**  
 0,385 kg/m  
 Estoque CD  
 TUB ITS  
 ■ ■

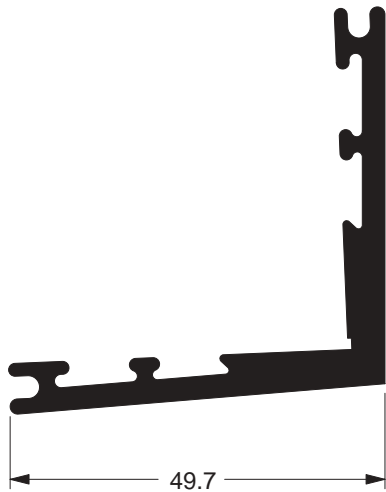

■  
**CL-006**  
 1,112 kg/m  
 Estoque CD  
 TUB ITS  
 ■ ■

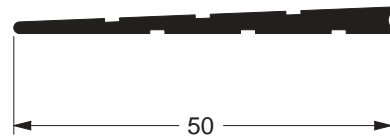

■  
**CL-011**  
 0,319 kg/m  
 Estoque CD  
 TUB ITS  
 ■ ■

Marco superior / correr 2

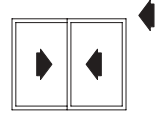
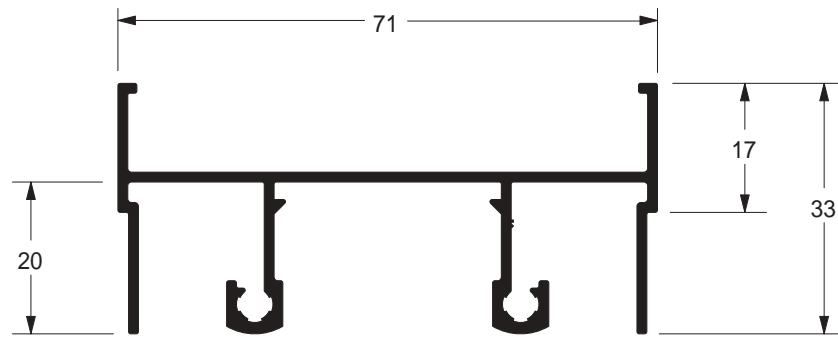

● **SU-001**  
 0,762 kg/m  
 Estoque CD  
 TUB ITS  
 ■ ■

Marco inferior / correr 2

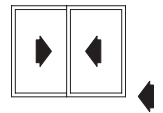
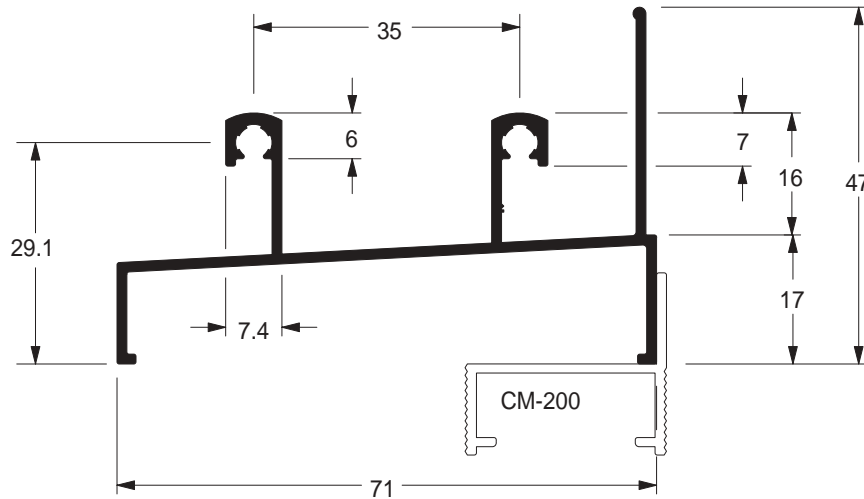

● **SU-002**  
 0,707 kg/m  
 Estoque CD  
 TUB ITS  
 ■ ■

Marco lateral / correr 2

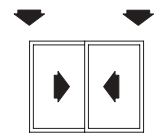
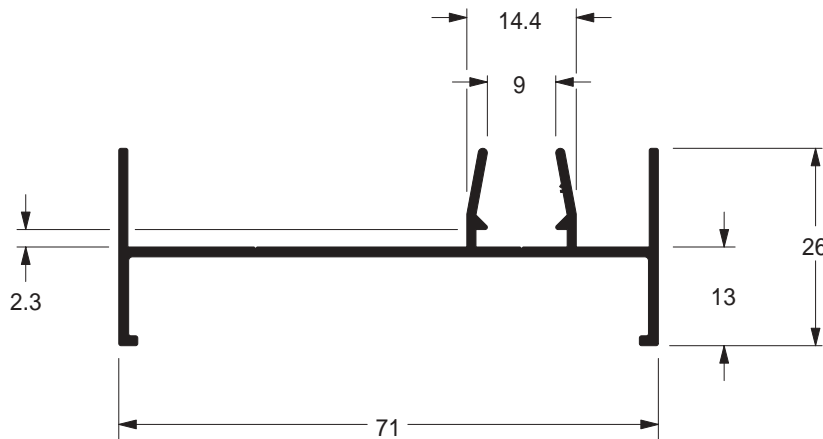

● **SU-003**  
 0,523 kg/m  
 Estoque CD  
 TUB ITS  
 ● ■ ■  
 ▲ ■ □

Marco inferior / correr 2

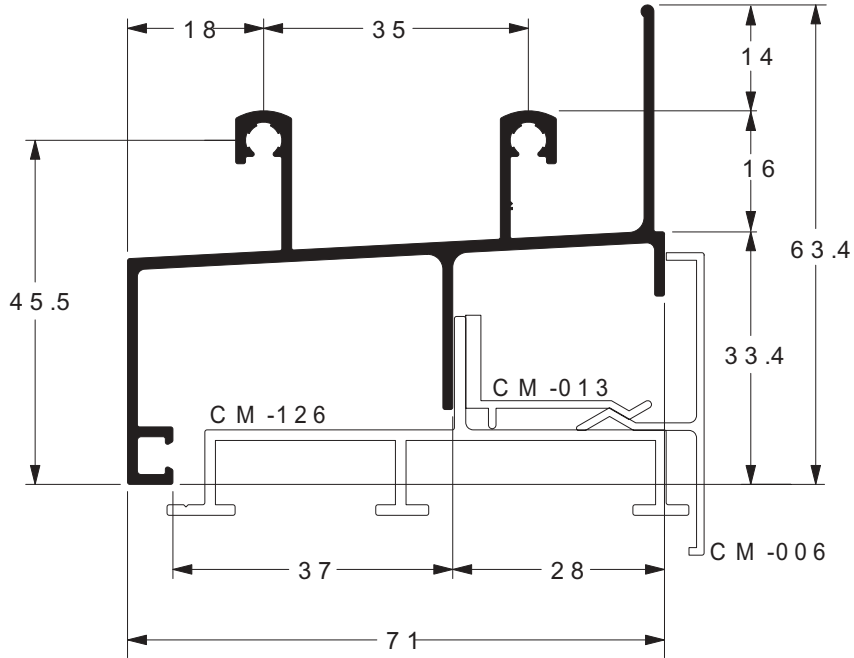
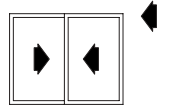

● **SU-251**  
 1,002 kg/m  
 Estoque CD  
 TUB ITS  
 ■ □

Marco superior / correr

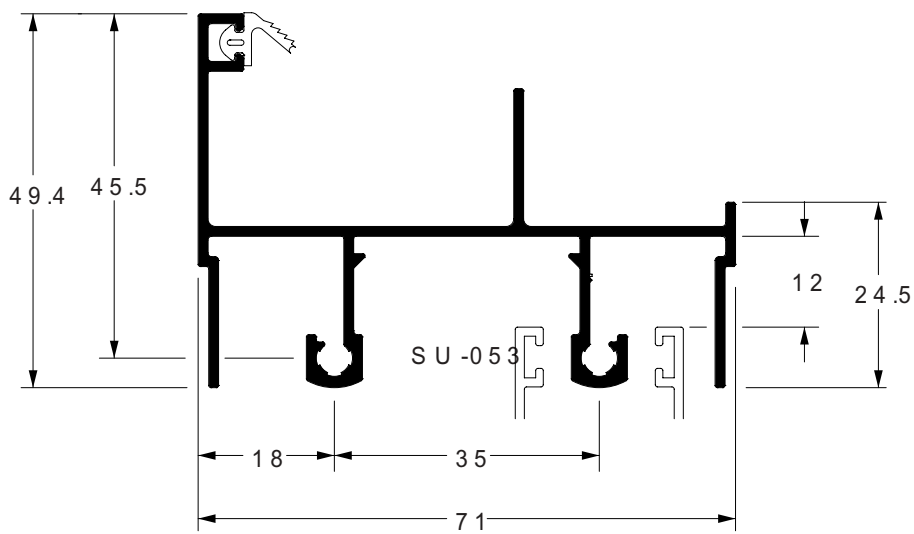
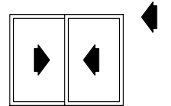

● **SU-026**  
 0,878 kg/m  
 Estoque CD  
 TUB ITS  
 ■ □

Marco bandeira peitoril / correr 2

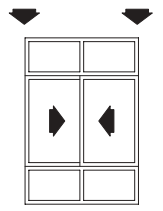
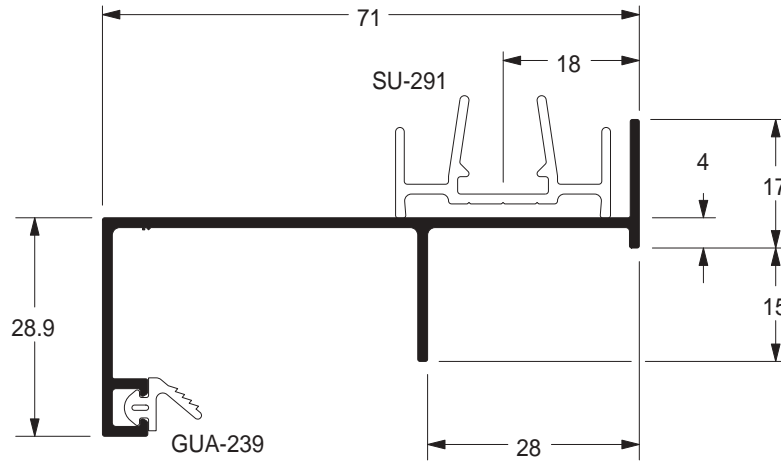

● **SU-028**  
 0,501 kg/m  
 Estoque CD  
 TUB ITS  
 ■ □

Marco bandeira peitoril / correr 2

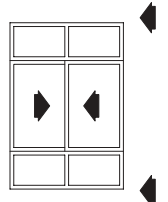
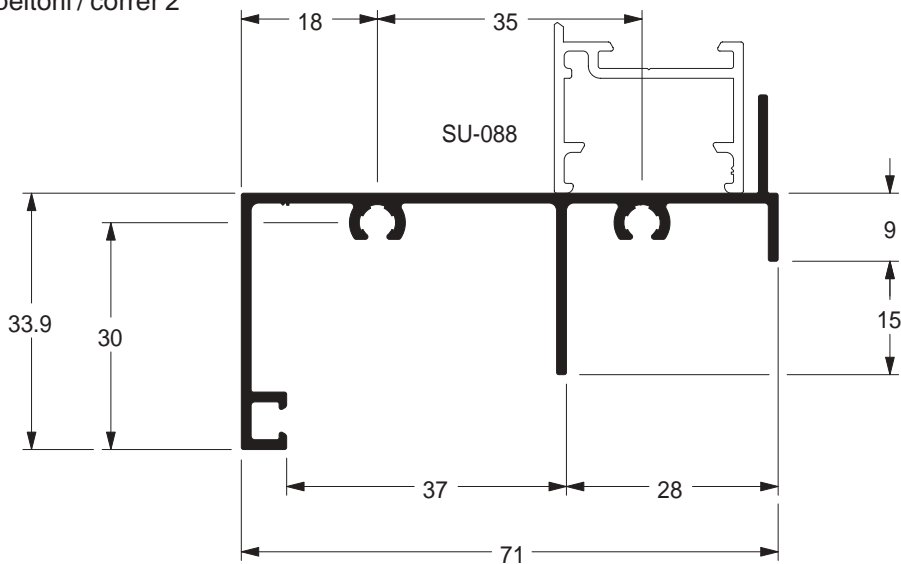

● **SU-029**  
 0,646 kg/m  
 Estoque CD  
 TUB ITS  
 ■ □

Marco / Maxim-ar / fixo

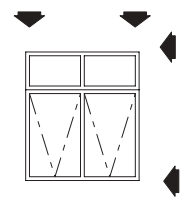
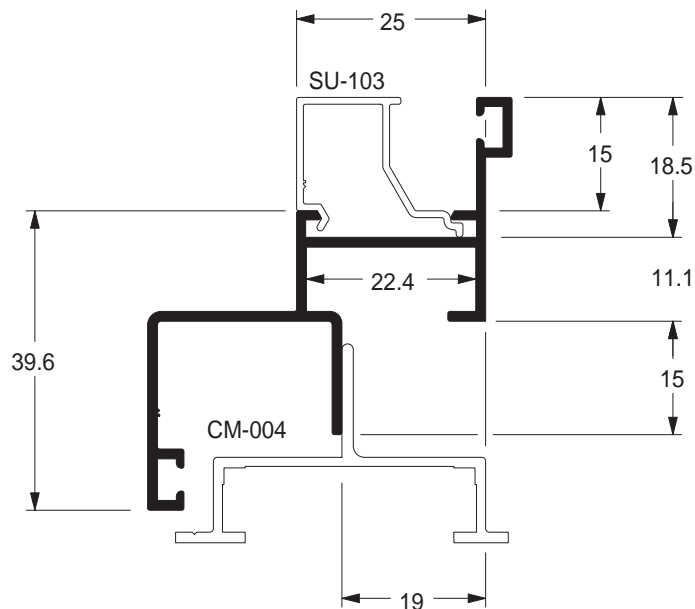

● **SU-030**  
 0,542 kg/m  
 Estoque CD  
 TUB ITS  
 ■ □

Marco bandeira peitoril / correr 2

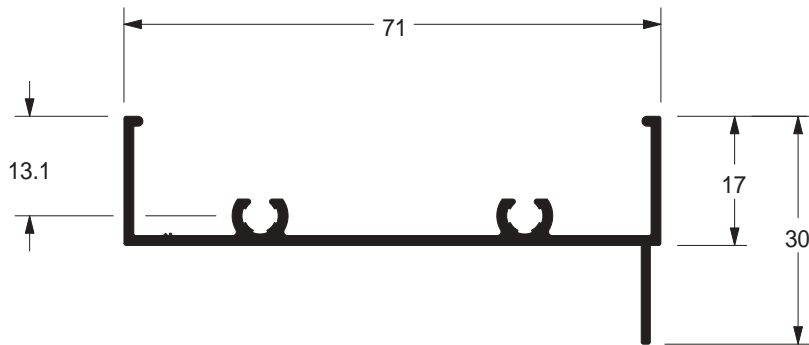

● **SU-004**  
 0,504 kg/m  
 Estoque CD  
 TUB ITS  
 ■ ■

Travessa bandeira / marco / correr 2

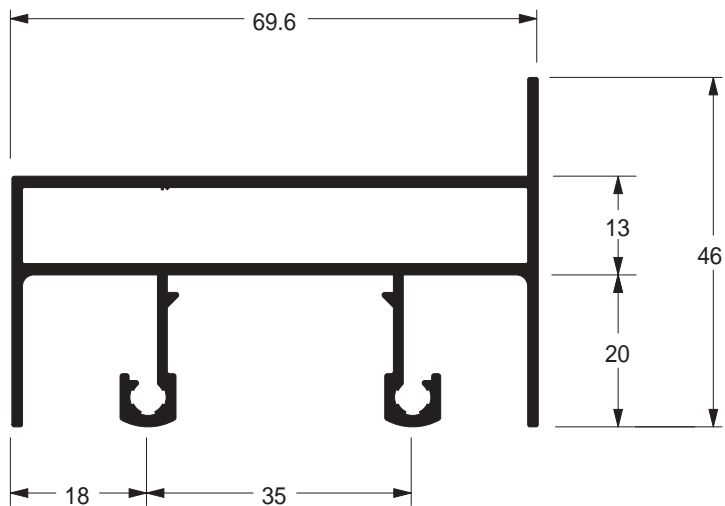

● **SU-005**  
 1,108 kg/m  
 Estoque CD  
 TUB ITS  
 ■ ■

Travessa peitoril / marco / correr 2

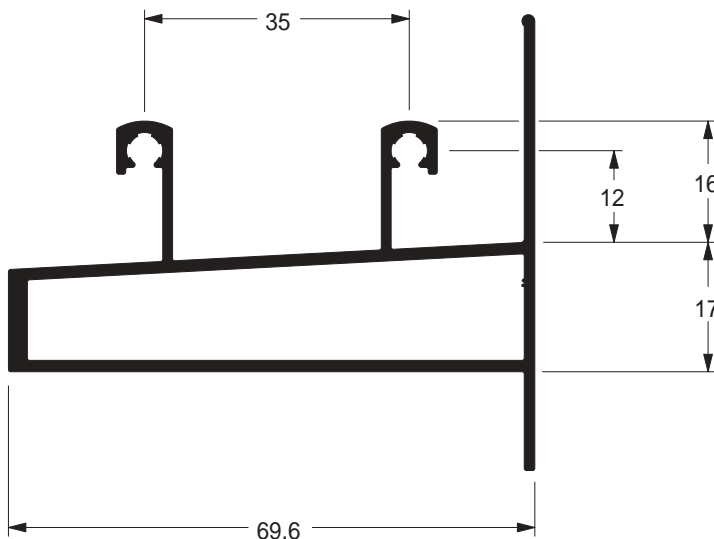

● **SU-006**  
 1,086 kg/m  
 Estoque CD  
 TUB ITS  
 ■ ■



Marco lateral / correr 2

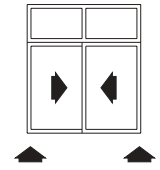
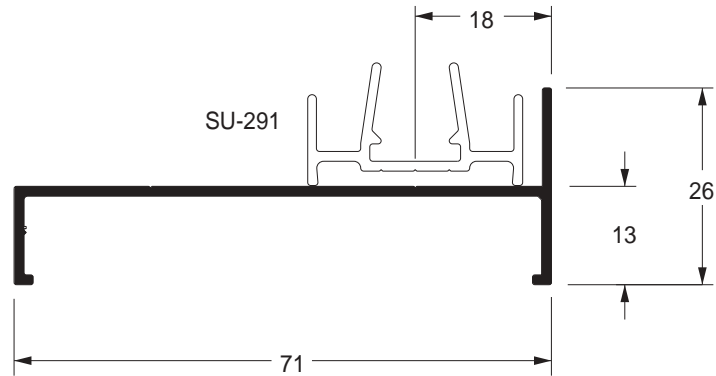

**SU-007**  
 0,382 kg/m  
 Estoque CD  
 TUB ITS



Complemento / marco lateral / correr

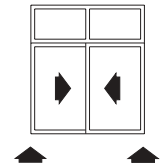
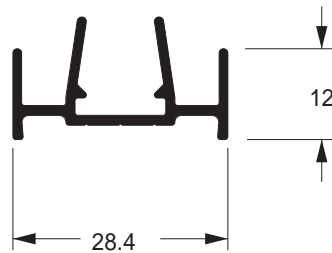

**SU-291**  
 0,263 kg/m  
 Estoque CD  
 TUB ITS



Coluna

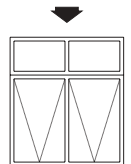
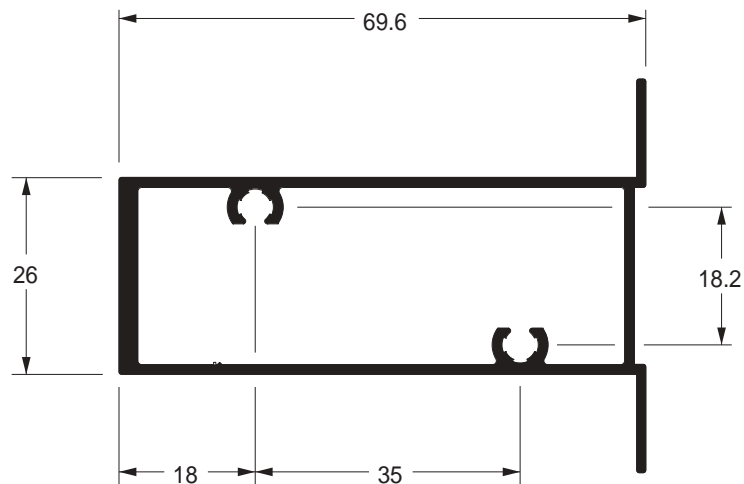

**SU-009**  
 0,908 kg/m  
 Estoque CD  
 TUB ITS



Marco superior / correr 3

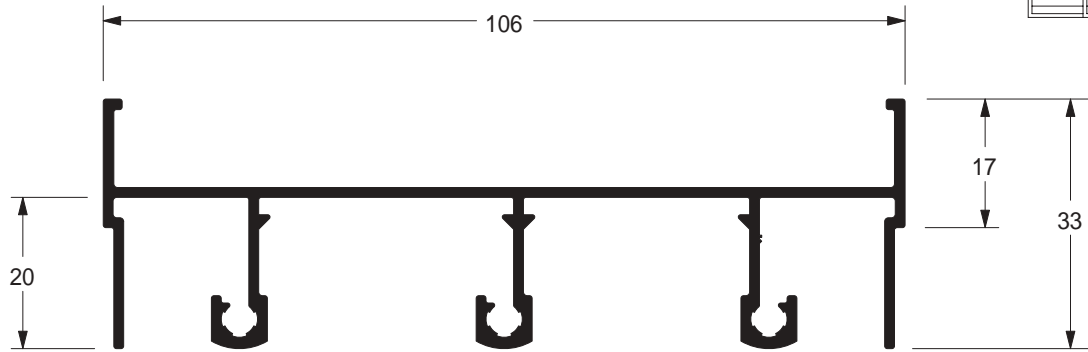

● **SU-010**  
 1,022 kg/m

Estoque CD  
 TUB ITS



Marco inferior / correr 3

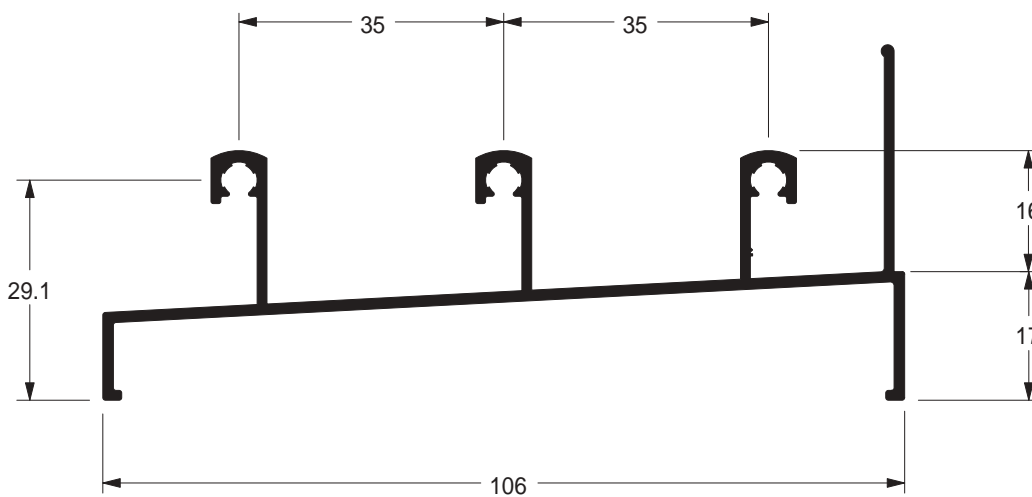

● **SU-011**  
 0,981 kg/m

Estoque CD  
 TUB ITS



Marco lateral / correr 3

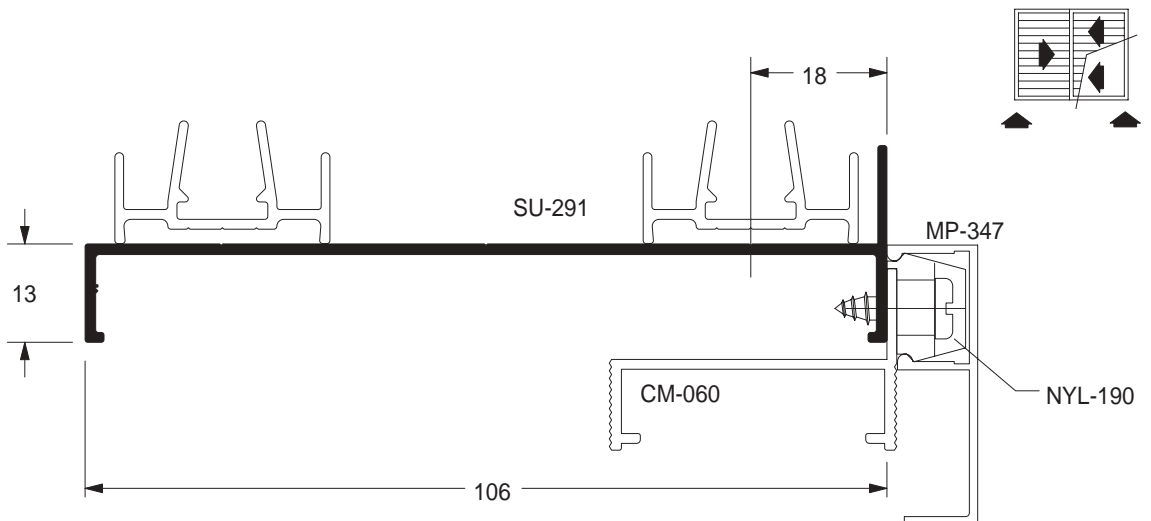

● **SU-012**  
 0,539 kg/m

Estoque CD  
 TUB ITS



Marco lateral / correr 3

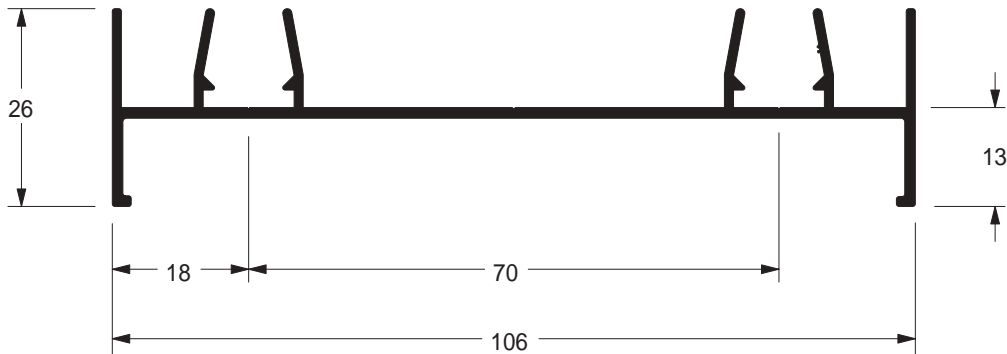

● **SU-013**  
 0,772 kg/m  
 Estoque CD  
 TUB ITS  
 ■ □

Marco lateral / correr 3

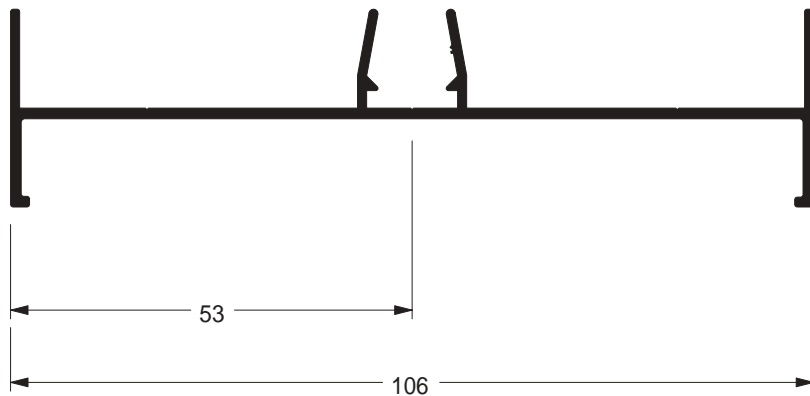

● **SU-014**  
 0,677 kg/m  
 Estoque CD  
 TUB ITS  
 ■ □

Travessa bandeira / marco / correr 3

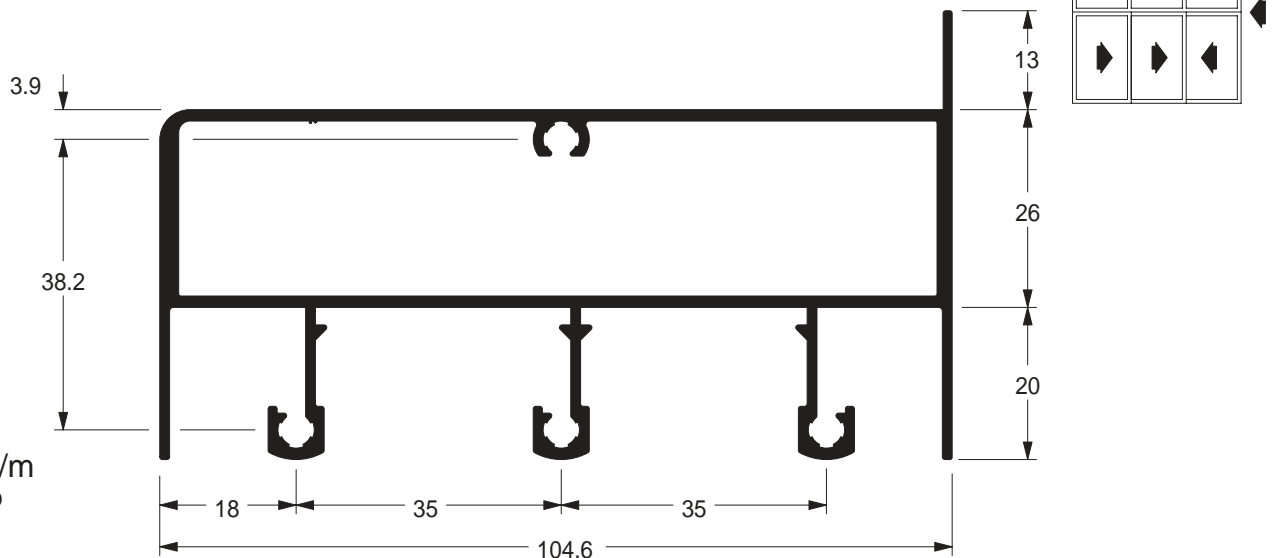

● **SU-019**  
 1,770 kg/m  
 Estoque CD  
 TUB ITS  
 ■ □

Marco inferior / correr 2

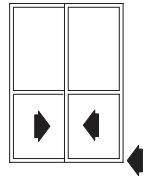
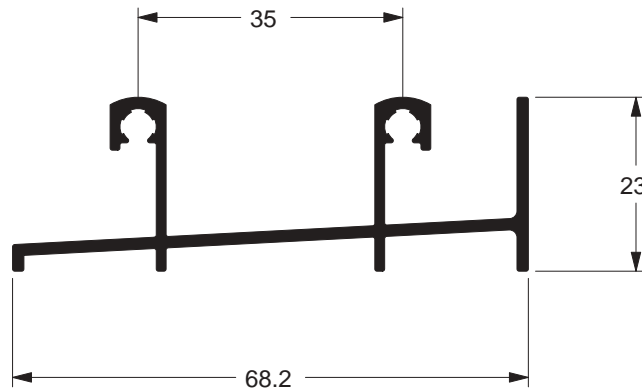

● **SU-260**  
 0,631 kg/m  
 Estoque CD  
 TUB ITS  
 ■ ■

Trilho porta

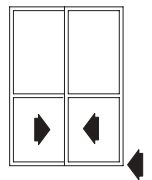
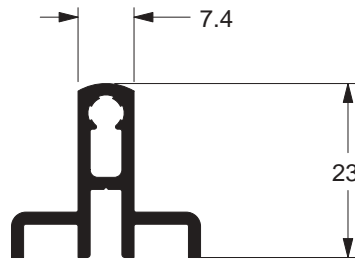

● **SU-271**  
 0,348 kg/m  
 Estoque CD  
 TUB ITS  
 ■ □

Trilho porta / correr 2

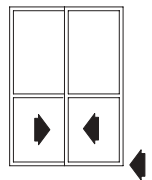
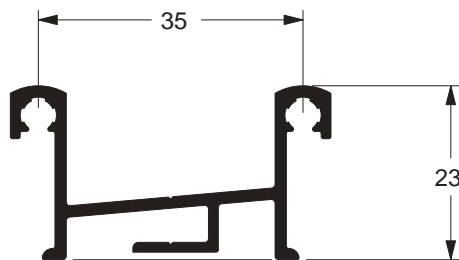

● **SU-272**  
 0,468 kg/m  
 Estoque CD  
 TUB ITS  
 ■ □

Marco superior / correr 4

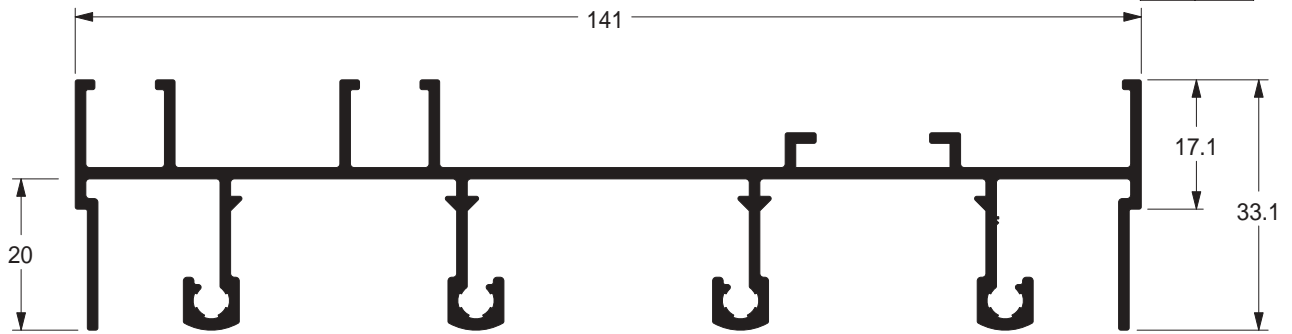

**SU-121**  
 1,586 kg/m

Estoque CD  
 TUB ITS



Marco inferior / correr 4

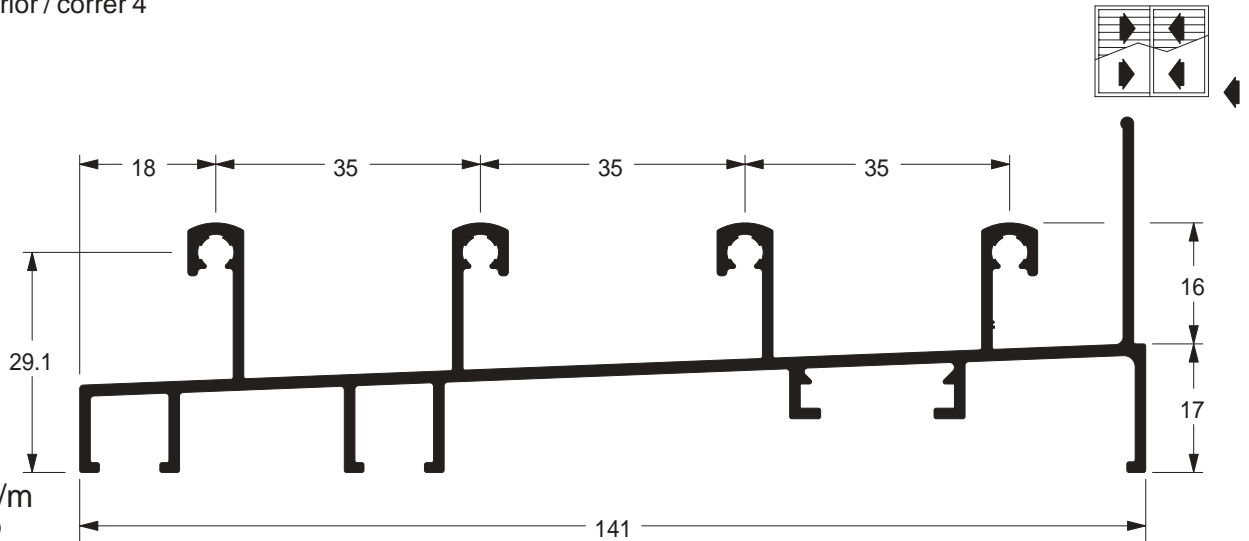

**SU-122**  
 1,512 kg/m

Estoque CD  
 TUB ITS



Marco lateral / correr 4

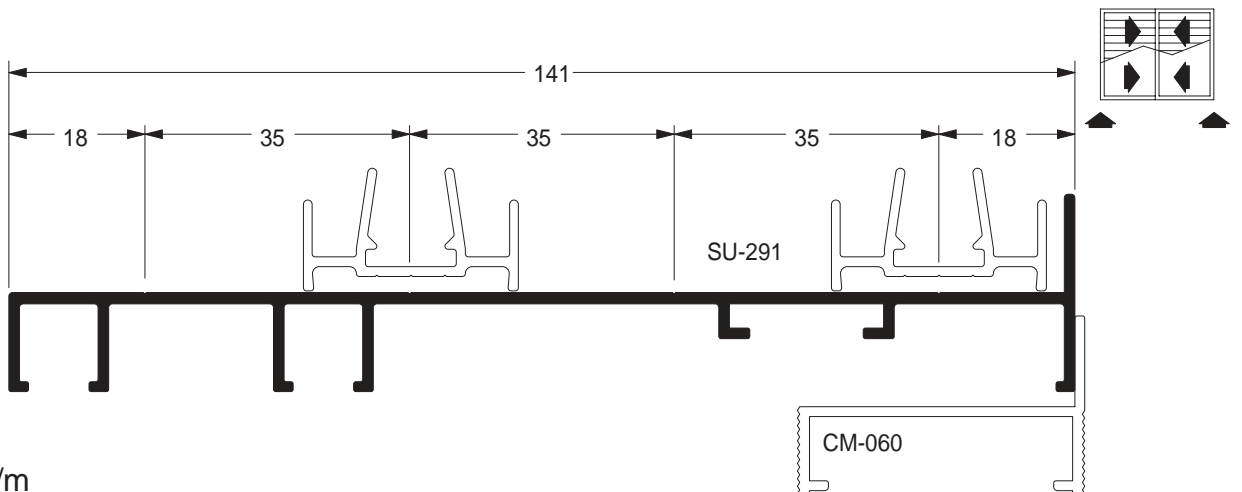

**SU-123**  
 0,919 kg/m

Estoque CD  
 TUB ITS



Marco superior / correr / veneziana camarão

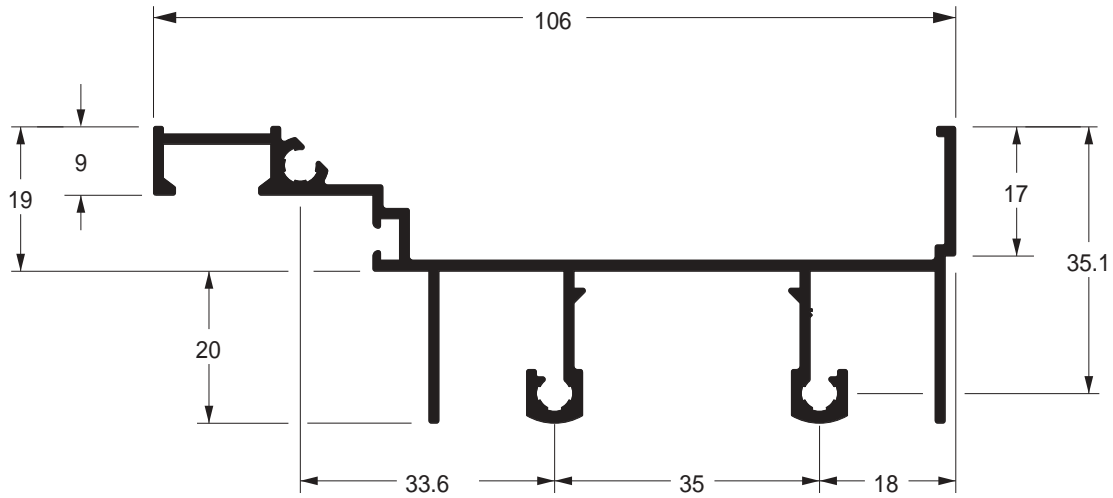
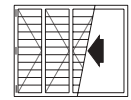

● **SU-024**  
 1,024 kg/m  
 Estoque CD  
 TUB ITS

Marco inferior / correr / veneziana camarão

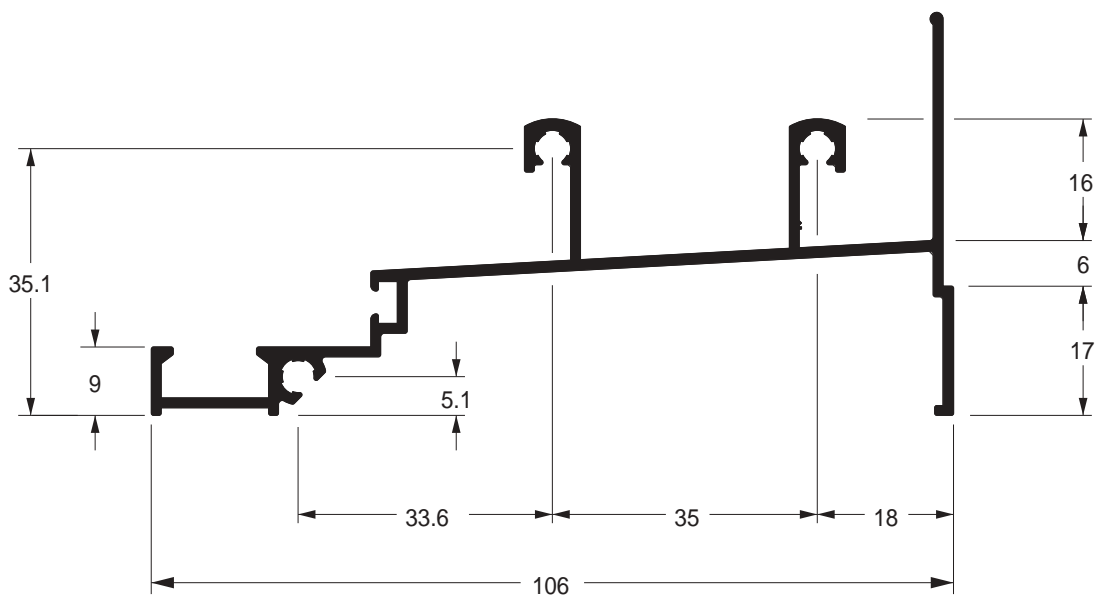
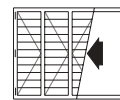

● **SU-025**  
 0,973 kg/m  
 Estoque CD  
 TUB ITS

Componente / coluna / correr 2

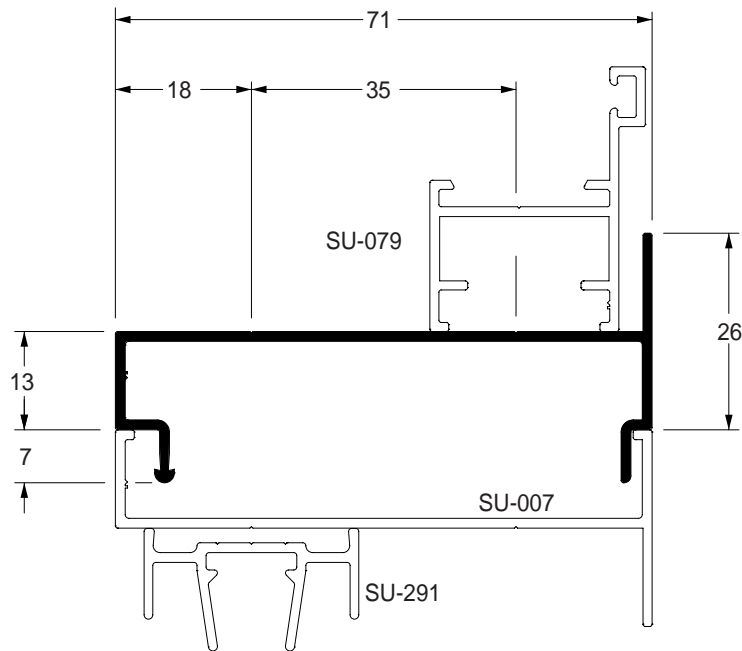

● **SU-036**  
 0,455 kg/m  
 Estoque CD  
 TUB ITS

Travessa superior bandeira / correr 3

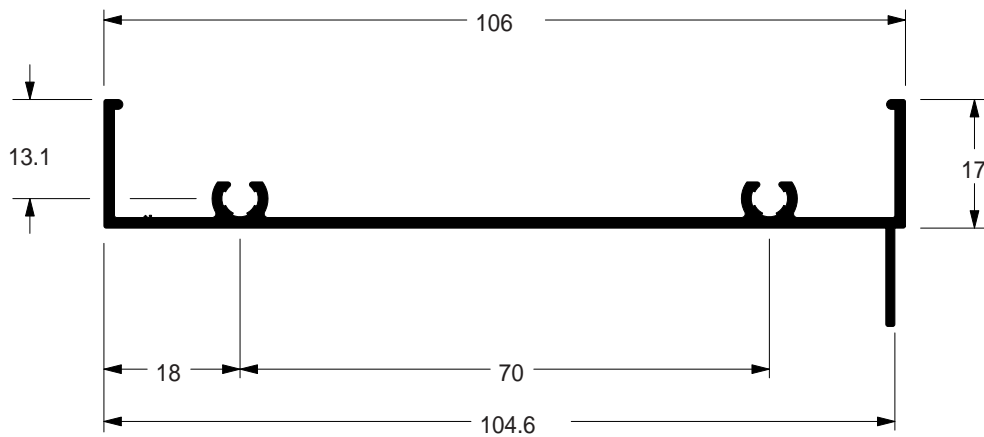

● **SU-018**  
 0,659 kg/m  
 Estoque CD  
 TUB ITS

Marco inferior / correr 2

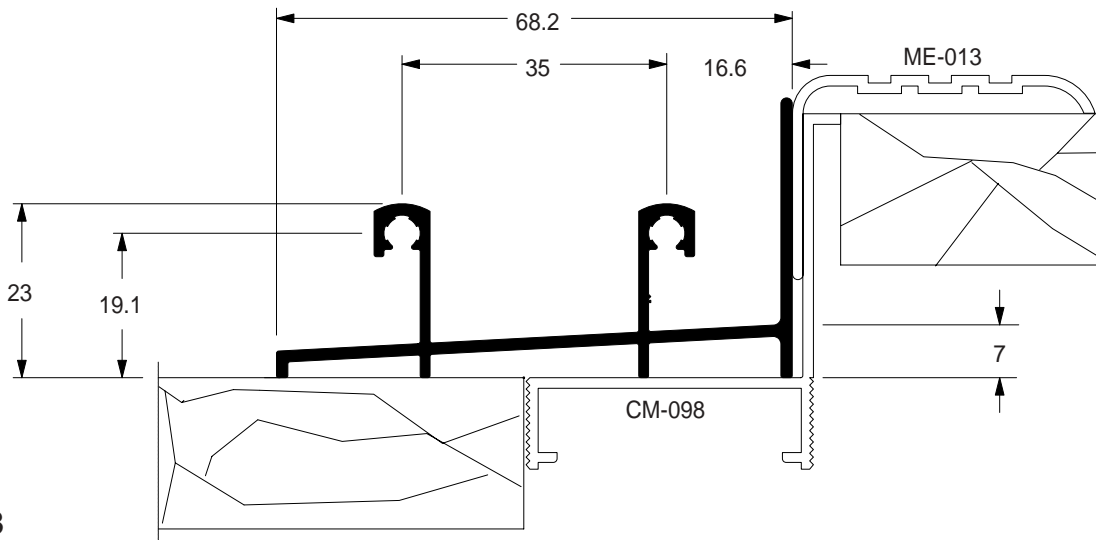
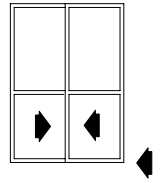

● **SU-228**  
 0,688 kg/m  
 Estoque CD  
 TUB ITS  
 ■ ■

Marco inferior / correr 3

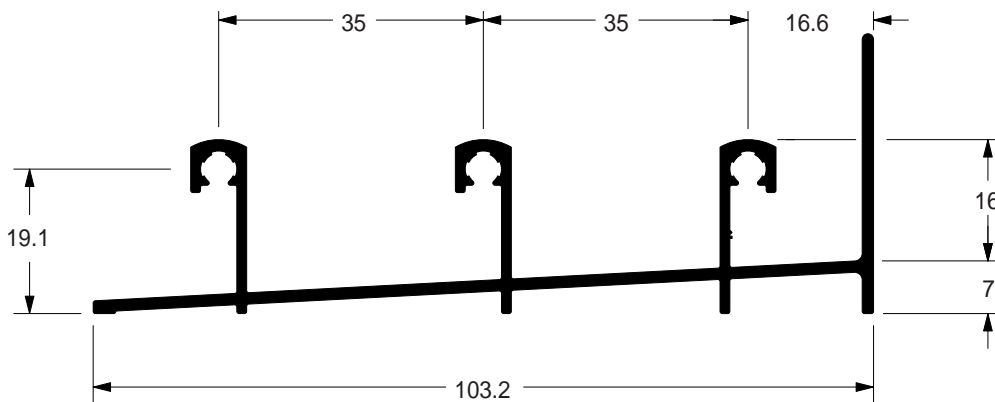
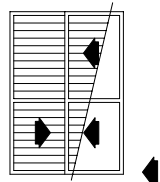

● **SU-230**  
 0,954 kg/m  
 Estoque CD  
 TUB ITS  
 ■ ■



Montante mão de amigo

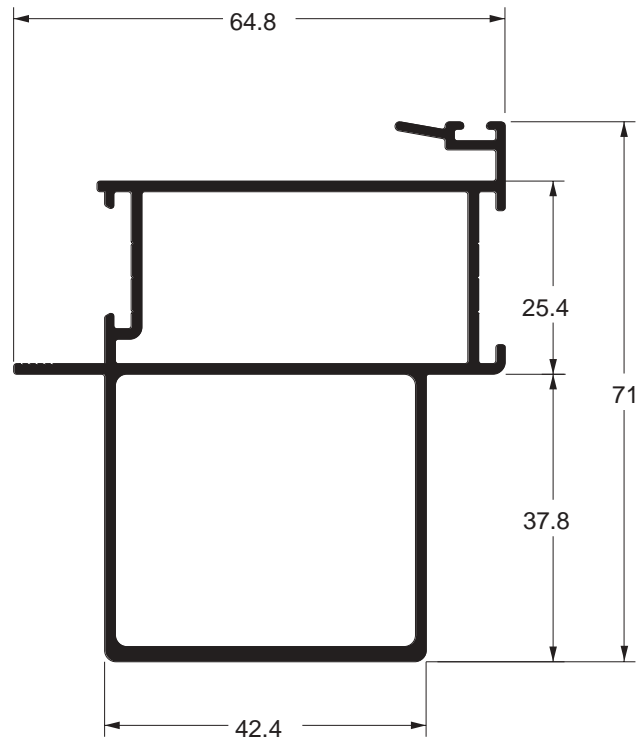

▲  
**SU-290**  
 1,247 kg/m  
 Estoque CD  
 TUB ITS  
 ■ □

Montante mão de amigo

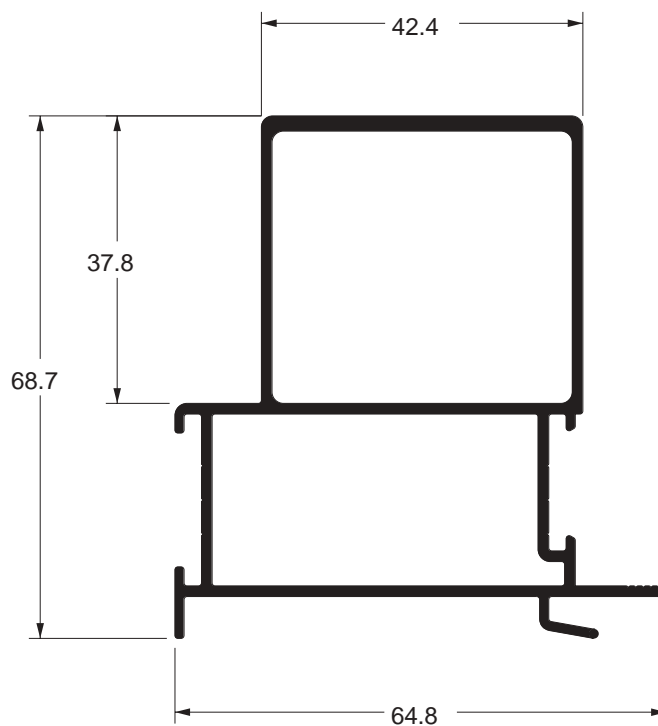

▲  
**SU-289**  
 1,217 kg/m  
 Estoque CD  
 TUB ITS  
 ■ □

Montante central folha / correr

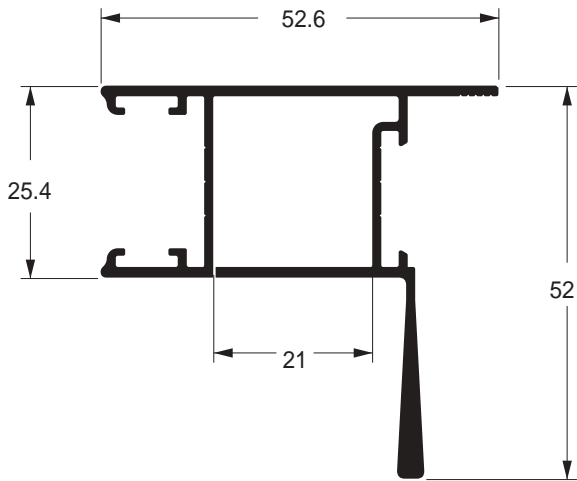
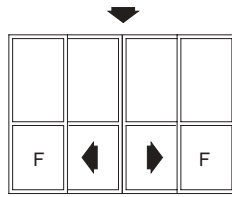

▲  
**SU-250**  
 0,736 kg/m  
 Estoque CD  
 TUB ITS  
 ■ □

Montante / folha / correr

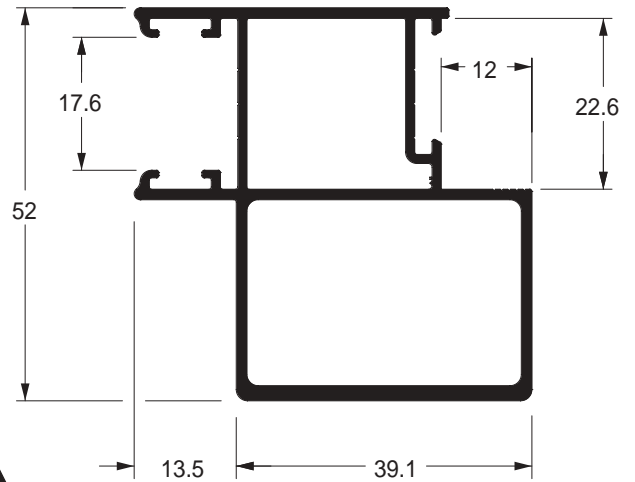
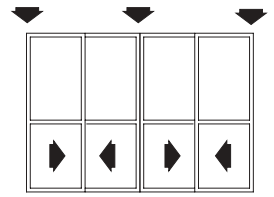

▲  
**SU-044**  
 0,970 kg/m  
 Estoque CD  
 TUB ITS  
 ■ ■

Montante mão de amigo

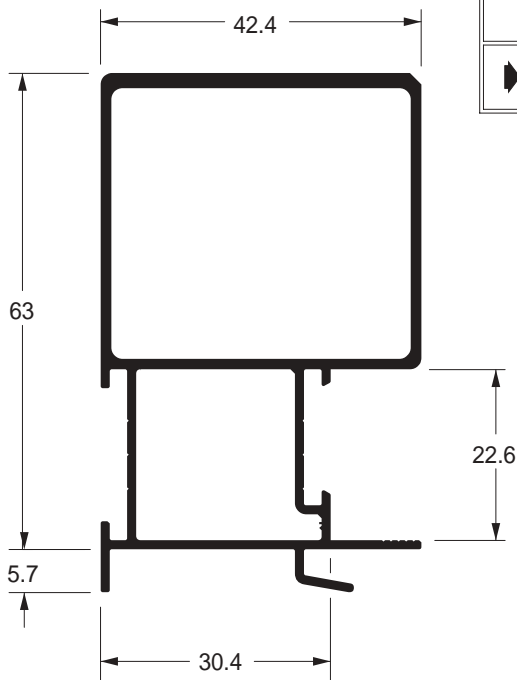
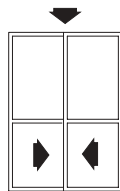

▲  
**SU-047**  
 1,041 kg/m  
 Estoque CD  
 TUB ITS  
 ■ ■

Montante mão de amigo

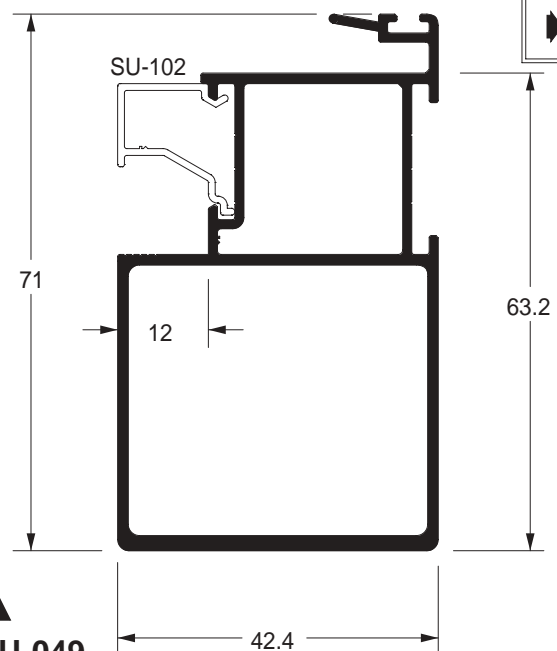
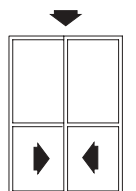

▲  
**SU-049**  
 1,052 kg/m  
 Estoque CD  
 TUB ITS  
 ■ ■

Travessa da folha

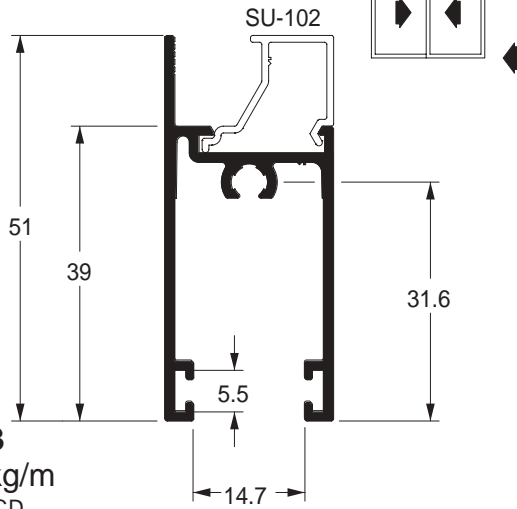

**SU-053**  
 0,507 kg/m  
 Estoque CD  
 TUB ITS

Montante da folha

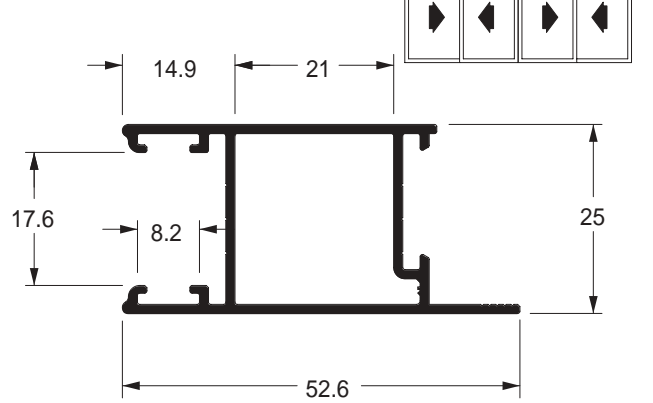

**SU-039**  
 0,520 kg/m  
 Estoque CD  
 TUB ITS

Montante mão de amigo

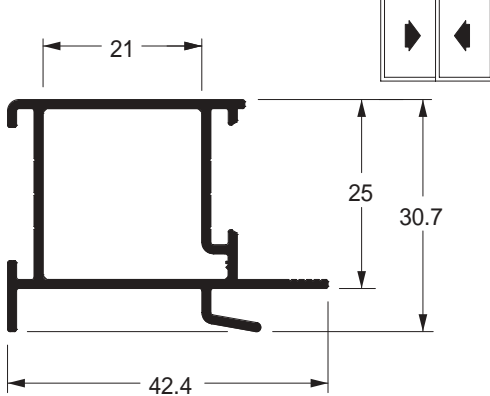

**SU-040**  
 0,480 kg/m  
 Estoque CD  
 TUB ITS

Montante mão de amigo

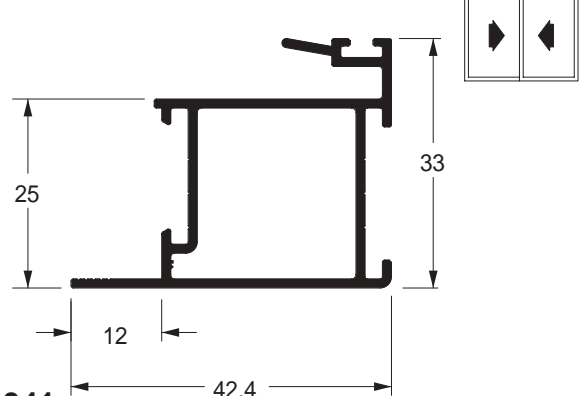

**SU-041**  
 0,507 kg/m  
 Estoque CD  
 TUB ITS

Montante mão de amigo

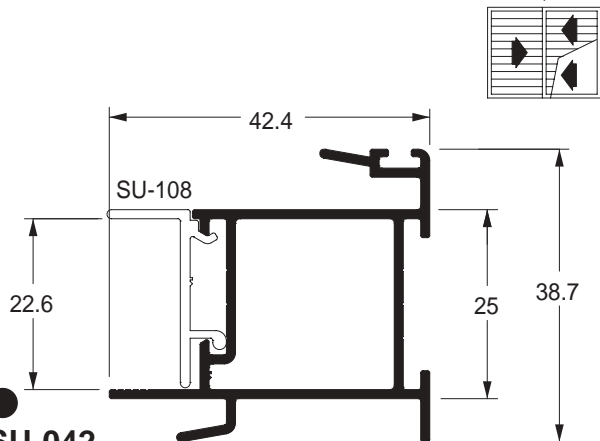

**SU-042**  
 0,564 kg/m  
 Estoque CD  
 TUB ITS

Montante folha vidro sem baguete

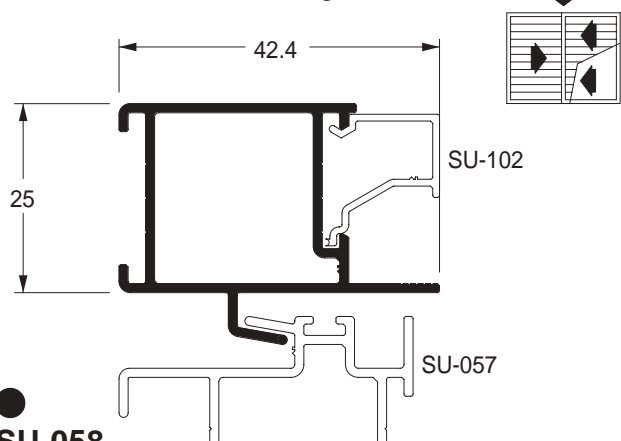

**SU-058**  
 0,463 kg/m  
 Estoque CD  
 TUB ITS

Montante mão de amigo

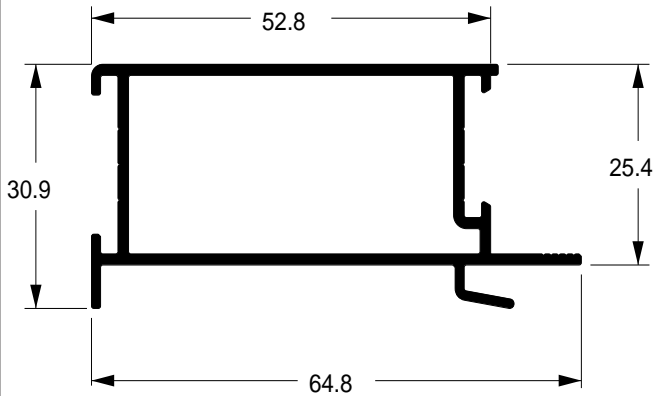
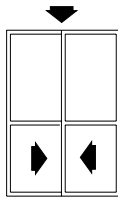

● **SU-243**  
 0,712 kg/m  
 Estoque CD  
 TUB ITS

Montante mão de amigo

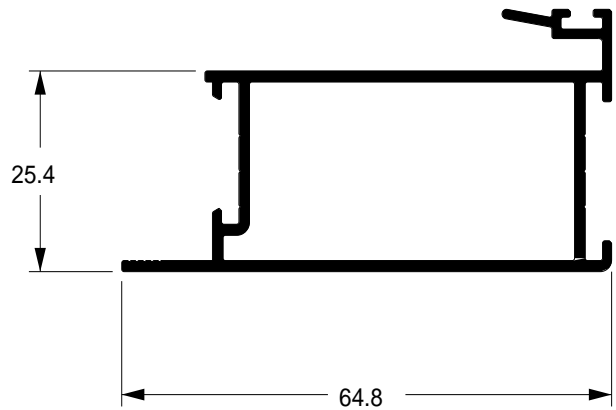
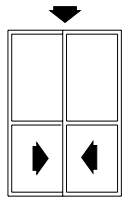

● **SU-242**  
 0,743 kg/m  
 Estoque CD  
 TUB ITS

Montante lateral da folha

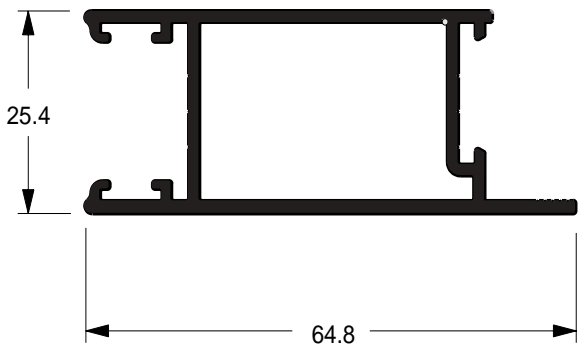
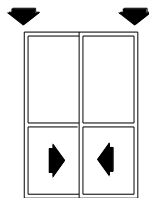

● **SU-245**  
 0.688 kg/m  
 Estoque CD  
 TUB ITS

Montante lateral da folha

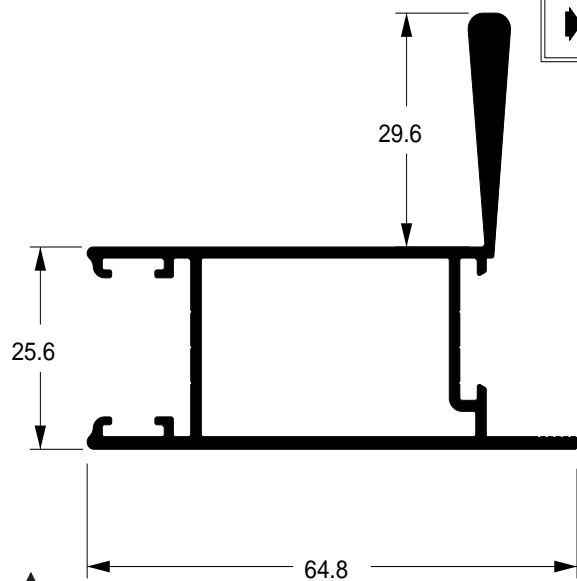
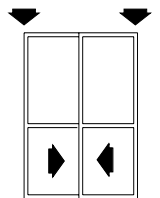

▲ **SU-280**  
 1,006 kg/m  
 Estoque CD  
 TUB ITS

Travessa central da folha

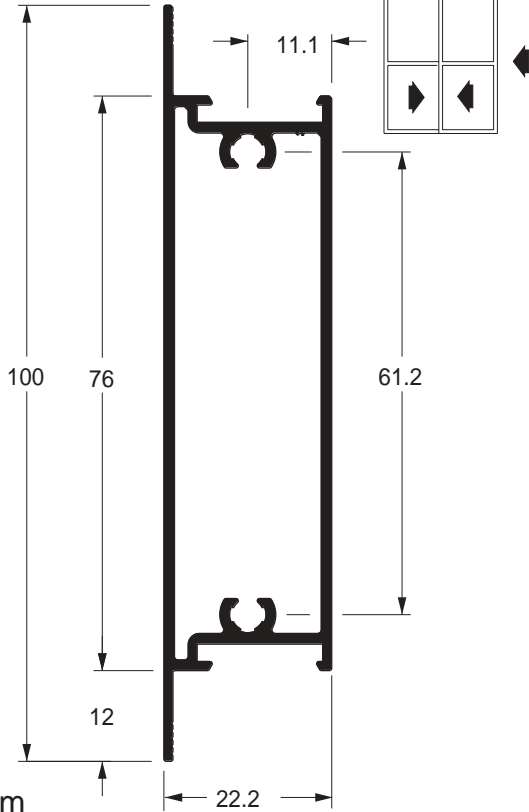

● **SU-050**  
 0,921 kg/m

Estoque CD  
 TUB ITS



Travessa central da folha

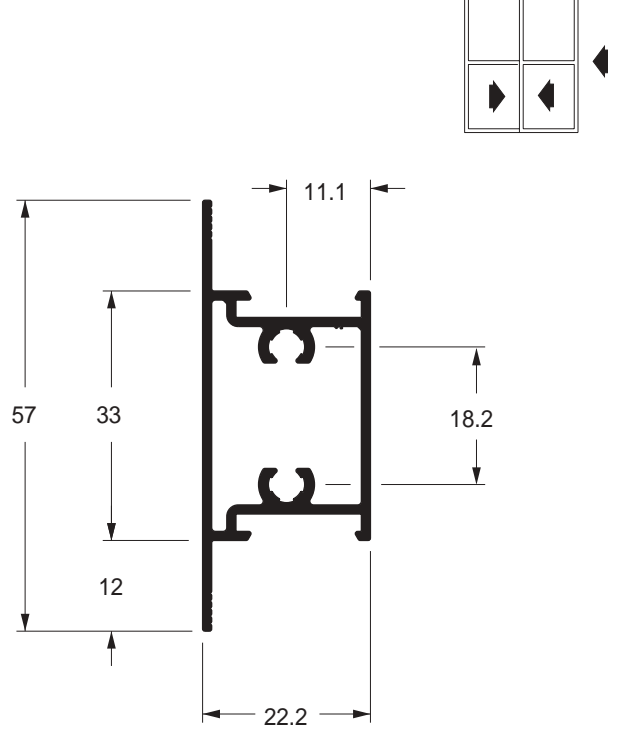

● **SU-227**  
 0,550 kg/m

Estoque CD  
 TUB ITS



Travessa inferior da folha

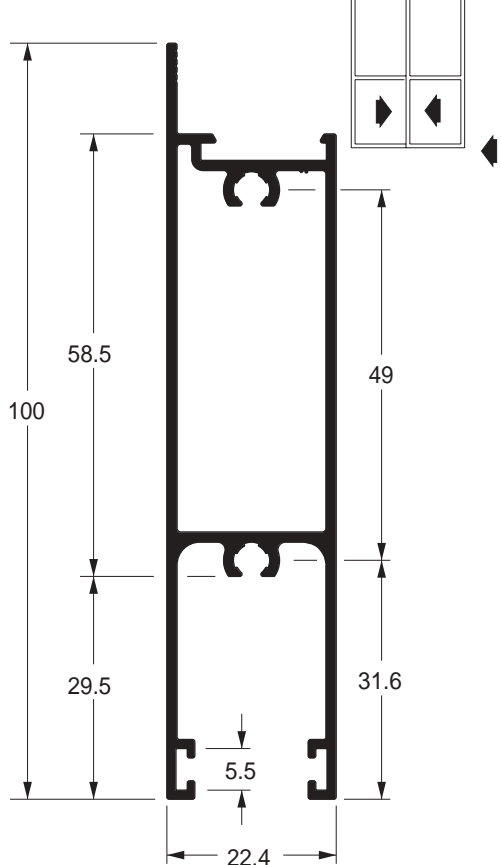

● **SU-225**  
 0,989 kg/m

Estoque CD  
 TUB ITS



Calço para folha fixa

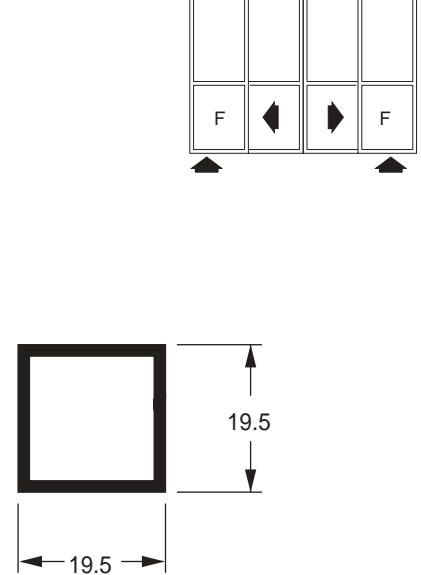

● **TQ-006**  
 0,303 kg/m

Estoque CD  
 TUB ITS



Montante mão de amigo

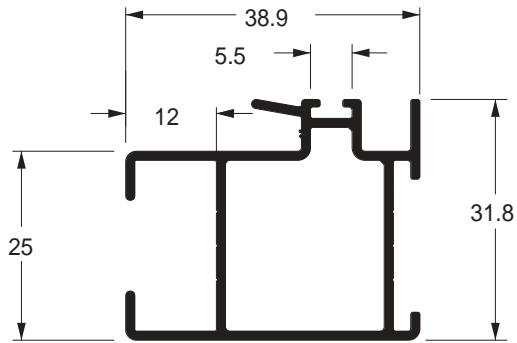
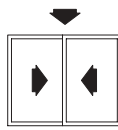

●  
**SU-056**  
 0,539 kg/m  
 Estoque CD  
 TUB ITS  
 ■ ■

Montante

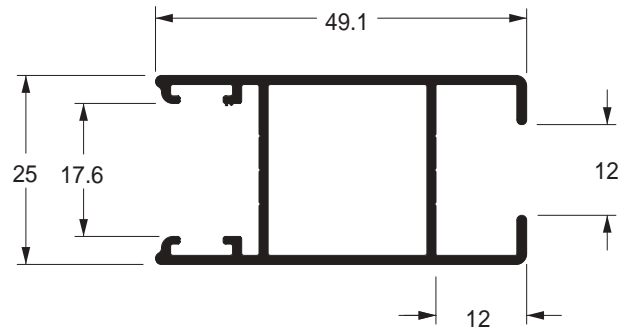
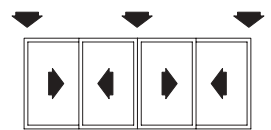

●  
**SU-055**  
 0,545 kg/m  
 Estoque CD  
 TUB ITS  
 ● ■ ■  
 ▲ ■ □

Montante mão de amigo

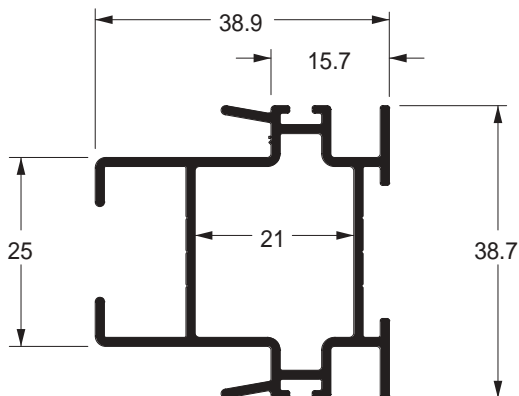
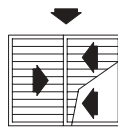

●  
**SU-057**  
 0,631 kg/m  
 Estoque CD  
 TUB ITS  
 ■ □

Montante

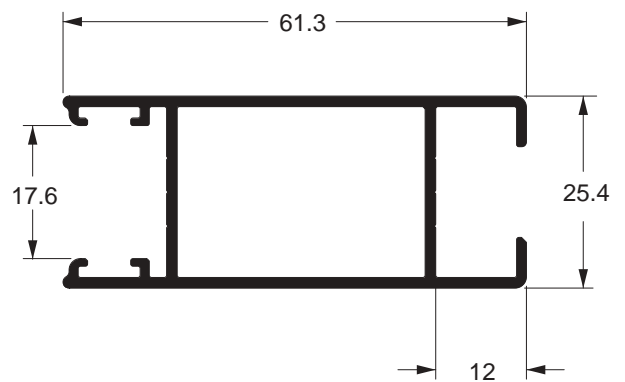
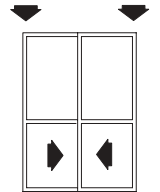

▲  
**SU-238**  
 0,714 kg/m  
 Estoque CD  
 TUB ITS  
 □ ■

Montante mão de amigo

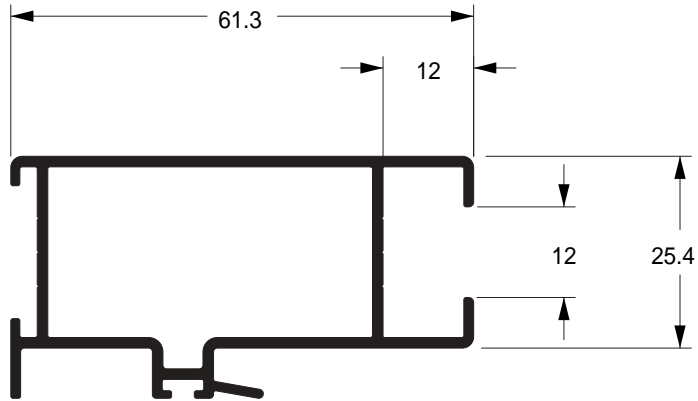
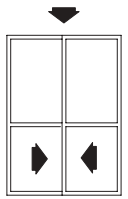

▲  
**SU-239**  
 0,783 kg/m  
 Estoque CD  
 TUB ITS

Travessa central da folha

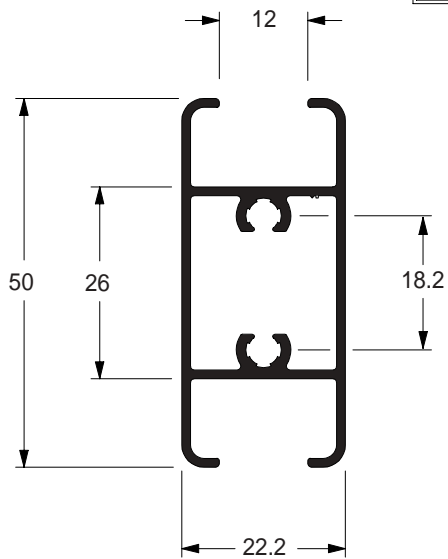
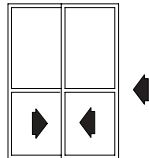

●  
**SU-188**  
 0,586 kg/m  
 Estoque CD  
 TUB ITS

Travessa da folha

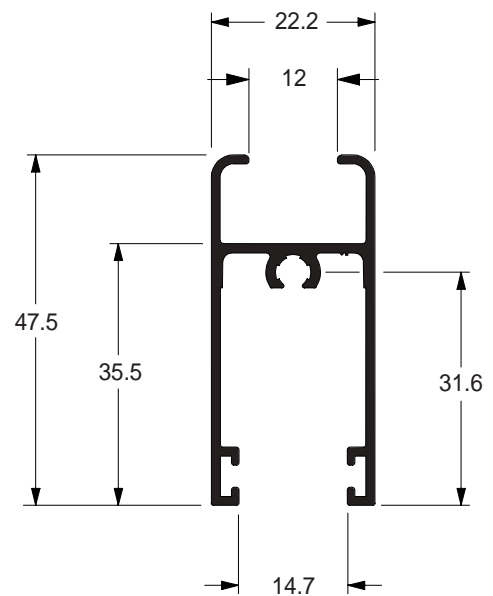
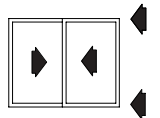

●  
**SU-186**  
 0,507 kg/m  
 Estoque CD  
 TUB ITS

Montante lateral da folha

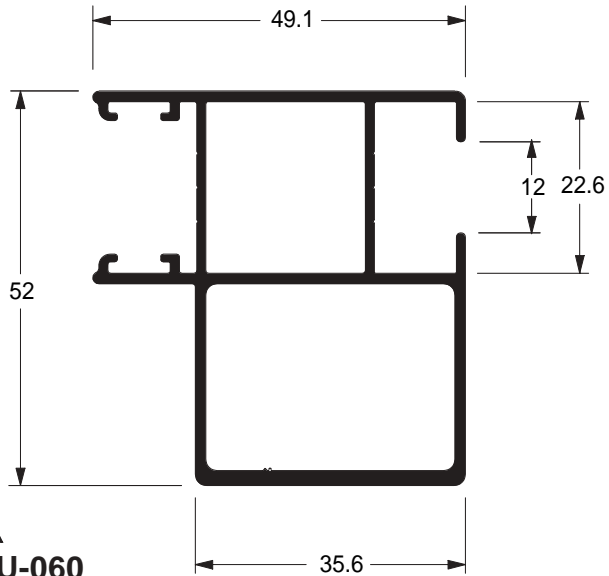
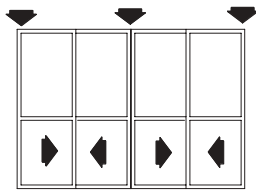

▲ **SU-060**  
 0,978 kg/m  
 Estoque CD  
 TUB ITS  
 ■ ■

Montante mão de amigo

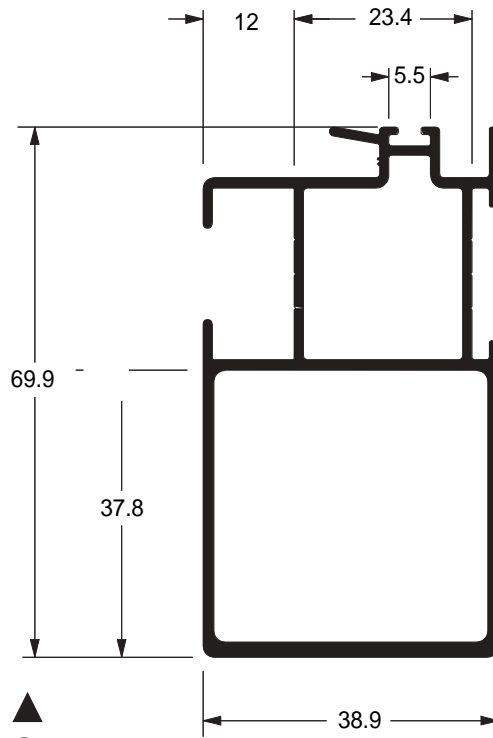
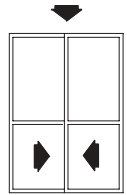

▲ **SU-061**  
 1,062 kg/m  
 Estoque CD  
 TUB ITS  
 ■ ■

Travessa inferior da folha

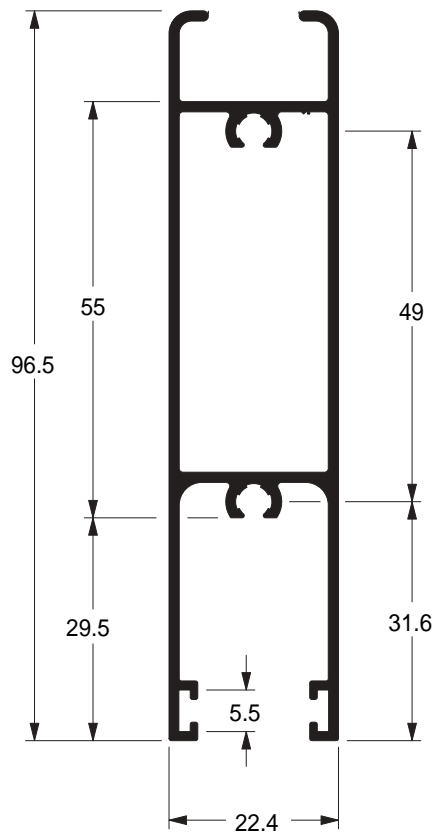
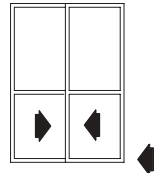

● **SU-226**  
 1,014 kg/m  
 Estoque CD  
 TUB ITS  
 ■ ■



Travessa da folha veneziana

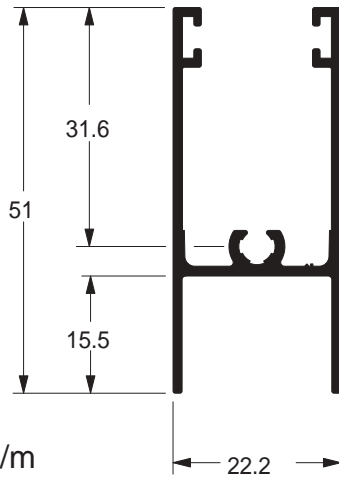

● **SU-187**  
 0,512 kg/m

Estoque CD  
 TUB ITS



Montante da folha veneziana

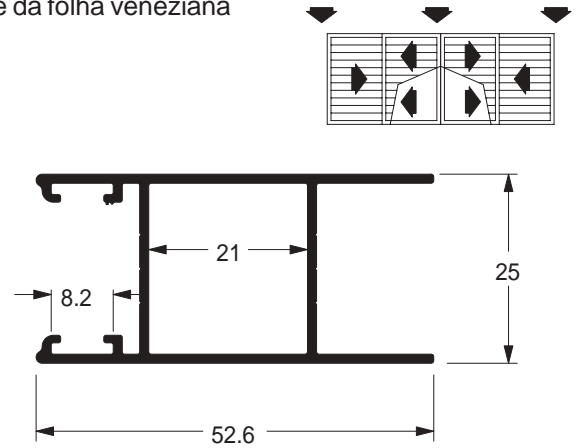

● **SU-068**  
 0,534 kg/m

Estoque CD  
 TUB ITS



Montante mão de amigo

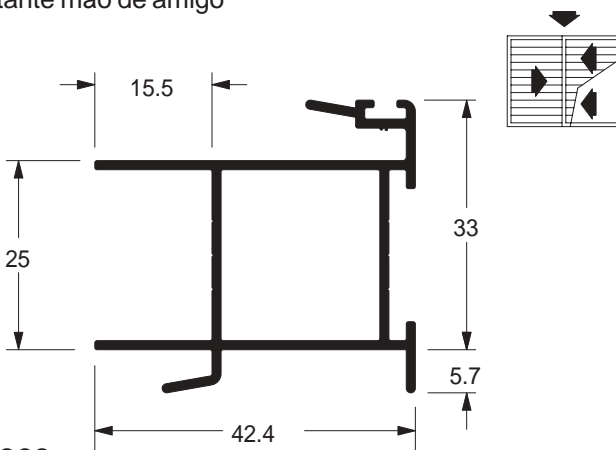

● **SU-069**  
 0,575 kg/m

Estoque CD  
 TUB ITS



Montante mão de amigo

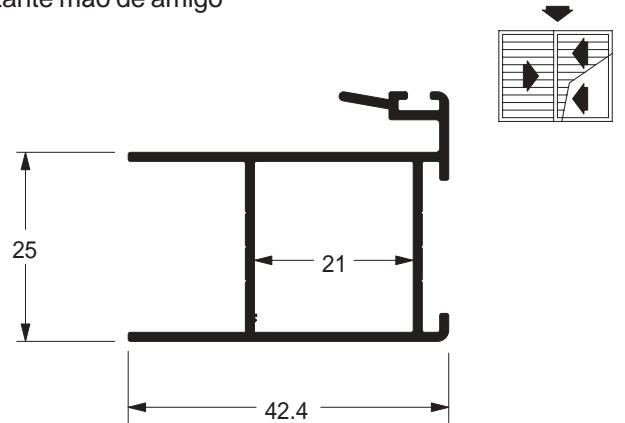

● **SU-070**  
 0,520 kg/m

Estoque CD  
 TUB ITS



Vedação do montante

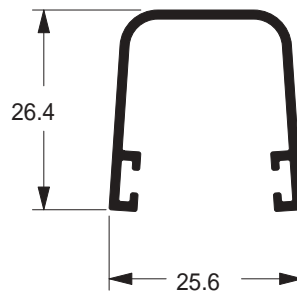

● **SU-107**  
 0,265 kg/m

Estoque CD  
 TUB ITS



Complemento marco

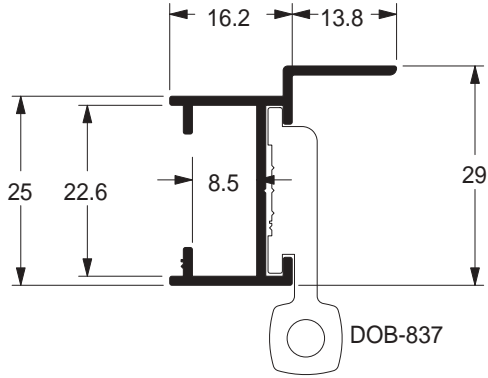
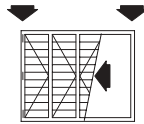

● **SU-071**  
 0,276 kg/m  
 Estoque CD  
 TUB ITS

Montante / folha veneziana

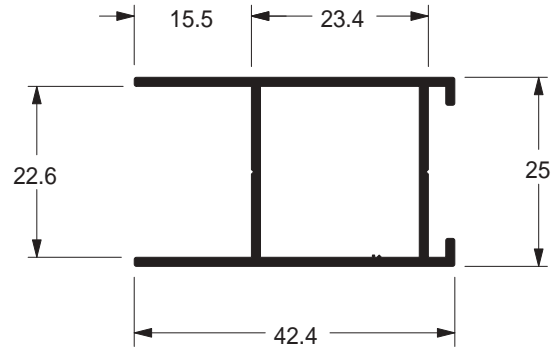
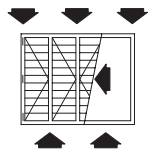

● **SU-072**  
 0,439 kg/m  
 Estoque CD  
 TUB ITS

Travessa / folha veneziana

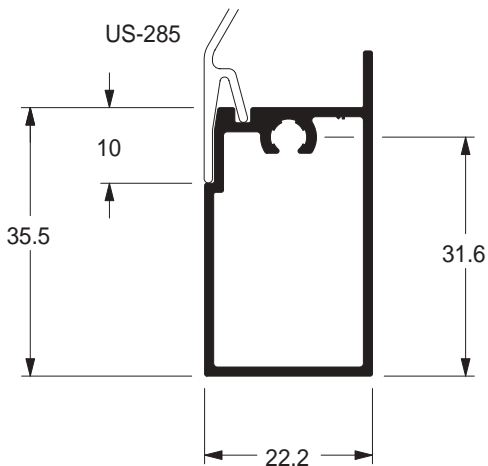
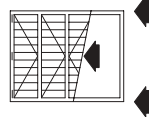

● **SU-073**  
 0,447 kg/m  
 Estoque CD  
 TUB ITS

Montante / folha veneziana

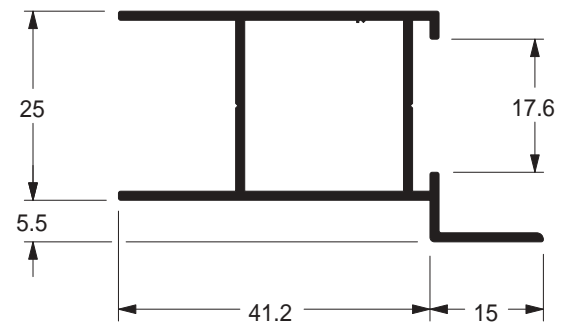
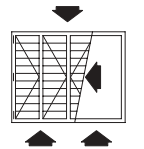

● **SU-074**  
 0,501 kg/m  
 Estoque CD  
 TUB ITS

Montante / travessa folha 45°

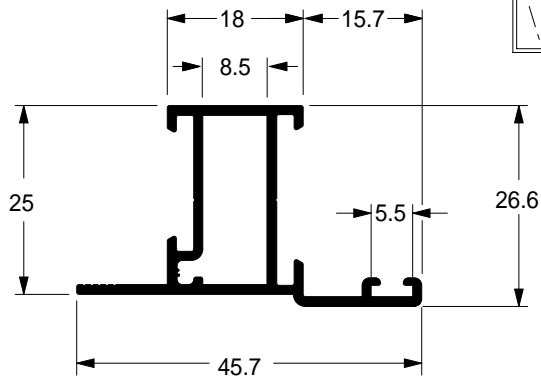

● **SU-200**  
 0,444 kg/m  
 Estoque CD  
 TUB ITS  
 ■ ■

Travessa superior folha 45°

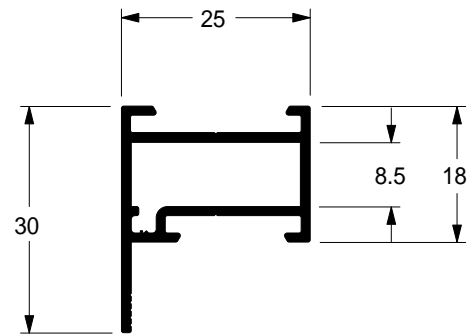

● **SU-080**  
 0,360 kg/m  
 Estoque CD  
 TUB ITS  
 ■ ■

Montante / folha

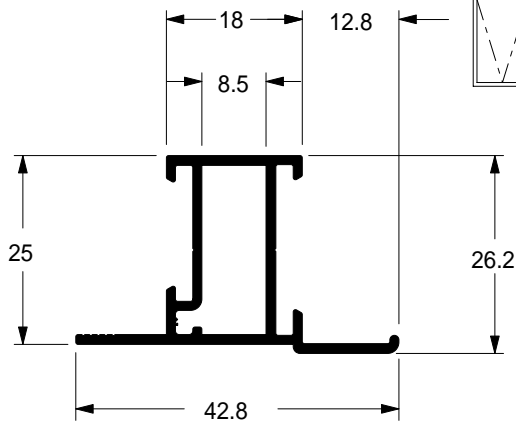

● **SU-081**  
 0,412 kg/m  
 Estoque CD  
 TUB ITS  
 ■ □

Travessa / folha

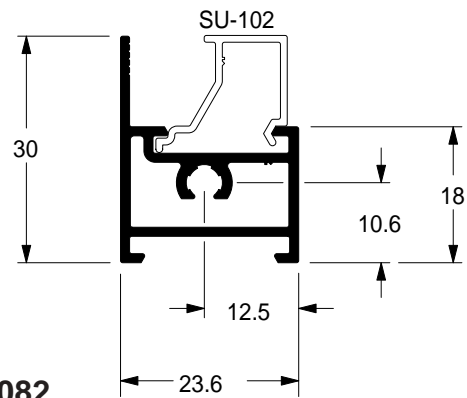

● **SU-082**  
 0,312 kg/m  
 Estoque CD  
 TUB ITS  
 ■ ■

Pingadeira / folha

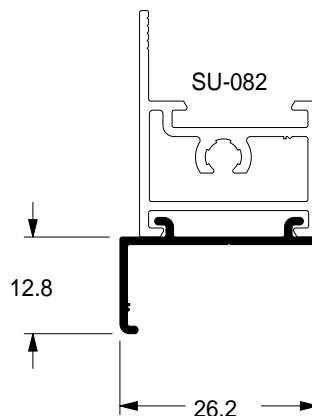

● **SU-084**  
 0,125 kg/m  
 Estoque CD  
 TUB ITS  
 ■ □

Montante / travessa inferior da folha 45°

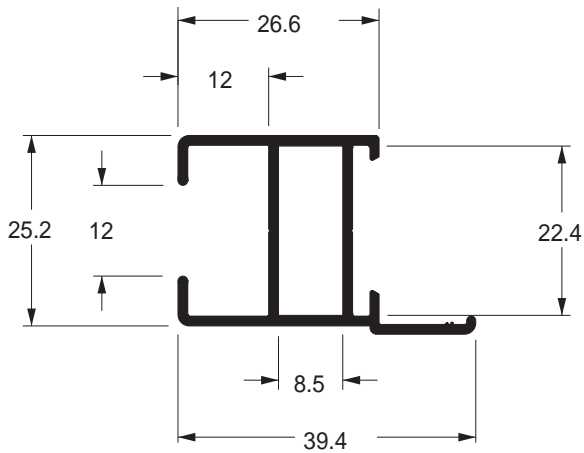

● **SU-090**  
 0,453 kg/m  
 Estoque CD  
 TUB ITS

Travessa superior da folha 45°

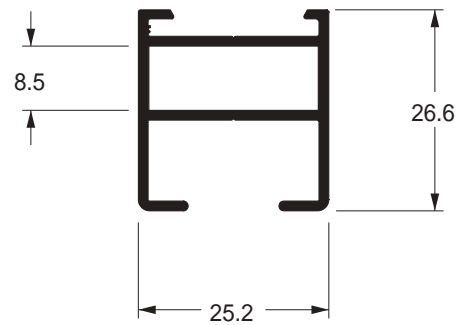
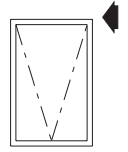

● **SU-091**  
 0,401 kg/m  
 Estoque CD  
 TUB ITS

Pingadeira

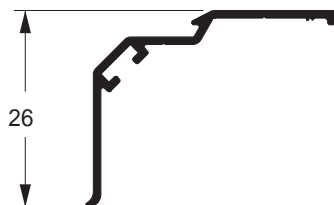
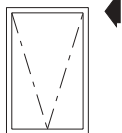

● **SU-276**  
 0,168 kg/m  
 Estoque CD  
 TUB ITS

Inversor para baguete

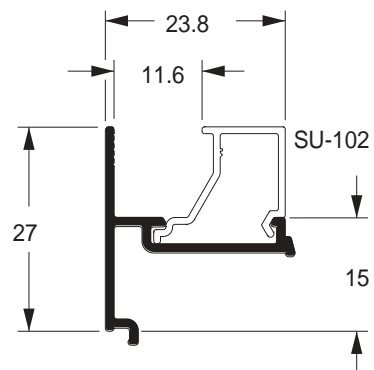
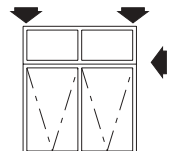

● **SU-292**  
 0,206 kg/m  
 Estoque CD  
 TUB ITS

Coluna / marco

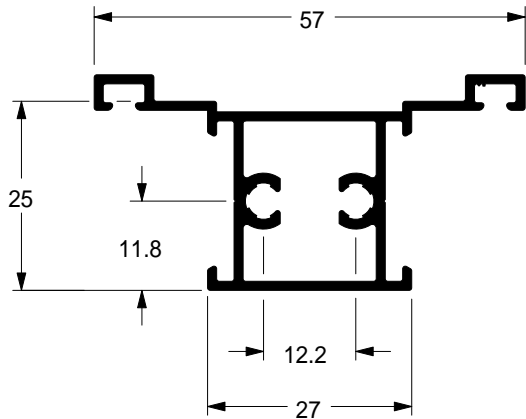
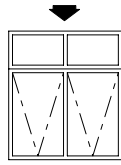

● **SU-086**  
 0,596 kg/m  
 Estoque CD  
 TUB ITS  
 ■ ■

Travessa / marco

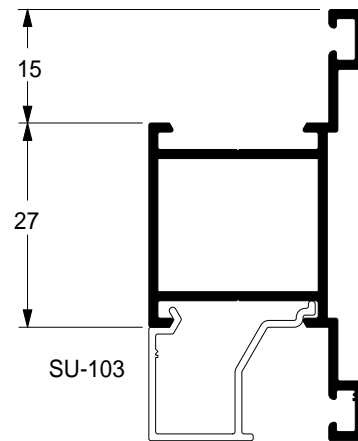
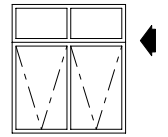

● **SU-085**  
 0,501 kg/m  
 Estoque CD  
 TUB ITS  
 ■ ■

Marco

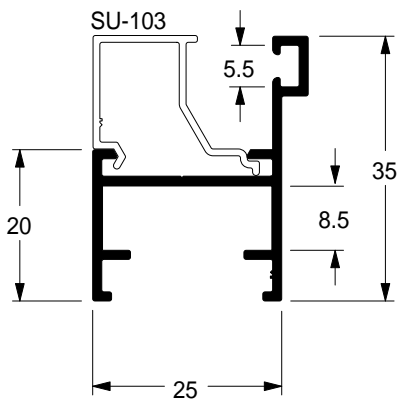
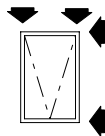

● **SU-079**  
 0,341 kg/m  
 Estoque CD  
 TUB ITS  
 ■ ■

Marco

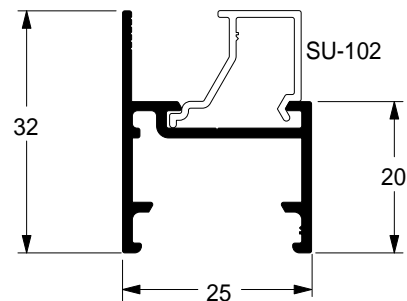
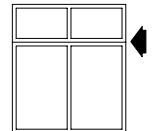

● **SU-088**  
 0,312 kg/m  
 Estoque CD  
 TUB ITS  
 ■ □

Marco

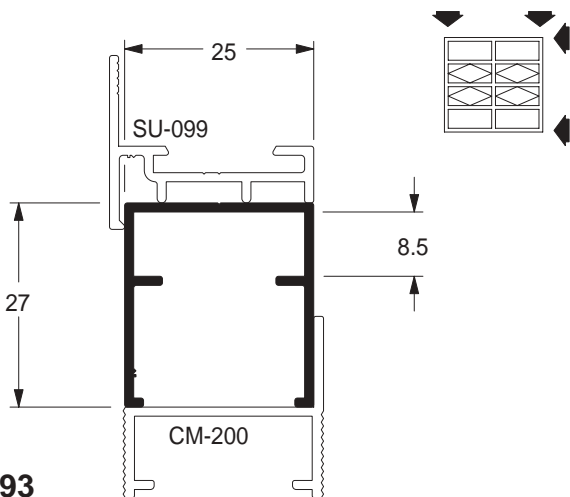

● **SU-093**  
 0,282 kg/m  
 Estoque CD  
 TUB ITS

Travessa / marco

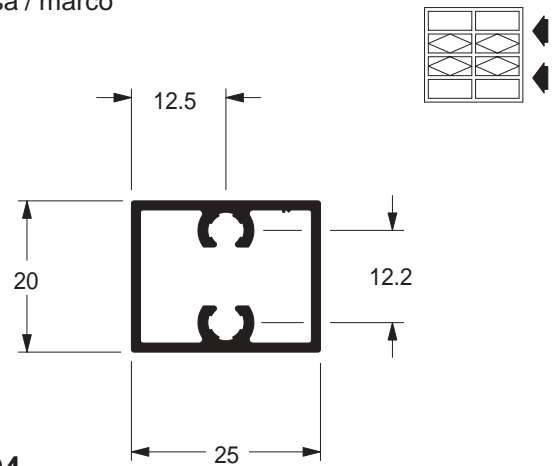

● **SU-094**  
 0,371 kg/m  
 Estoque CD  
 TUB ITS

Suporte

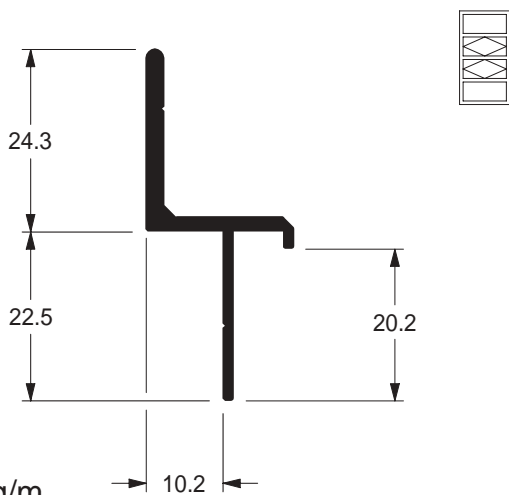

● **SU-101**  
 0,360 kg/m  
 Estoque CD  
 TUB ITS

Montante / folha

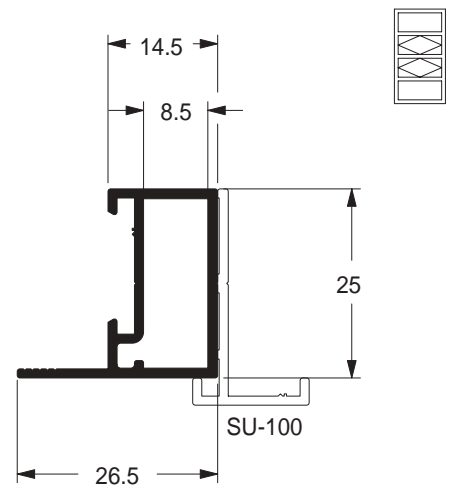

● **SU-096**  
 0,314 kg/m  
 Estoque CD  
 TUB ITS

Travessa / folha

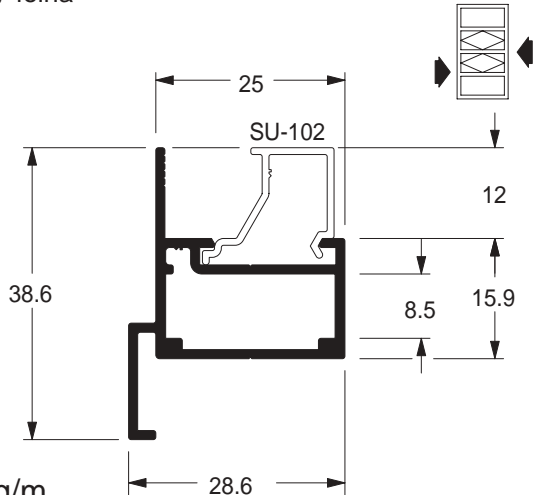

● **SU-097**  
 0,401 kg/m  
 Estoque CD  
 TUB ITS

Travessa / folha

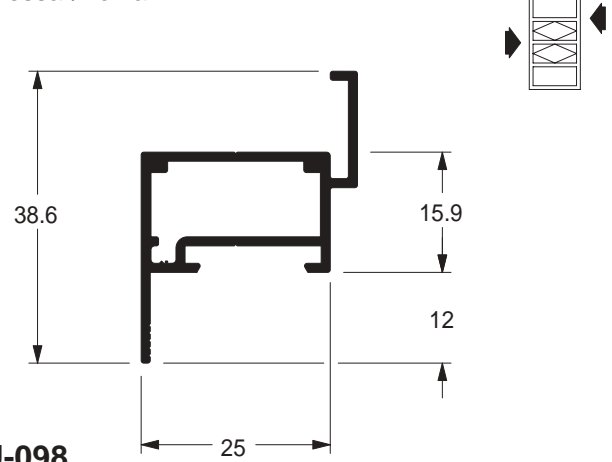

● **SU-098**  
 0,401 kg/m  
 Estoque CD  
 TUB ITS

Baguete

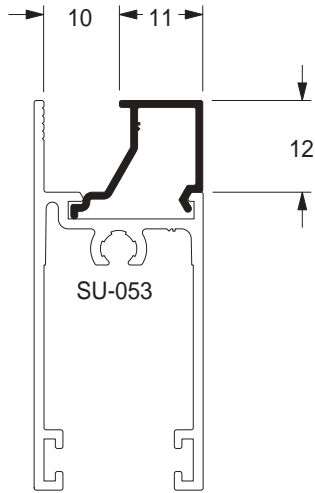

● **SU-102**  
 0,111 kg/m  
 Estoque CD  
 TUB ITS

Baguete

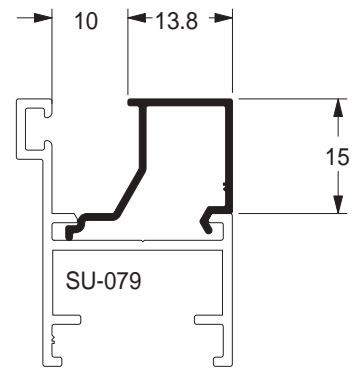

● **SU-103**  
 0,140 kg/m  
 Estoque CD  
 TUB ITS

Complemento veneziana 22 folha / correr

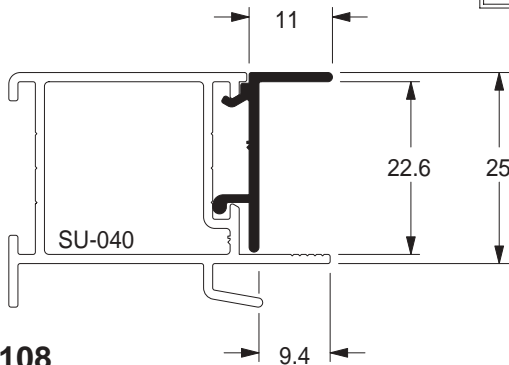
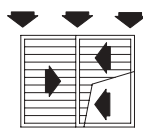

● **SU-108**  
 0,146 kg/m  
 Estoque CD  
 TUB ITS

Acoplador veneziana 12 e 22 folha / correr

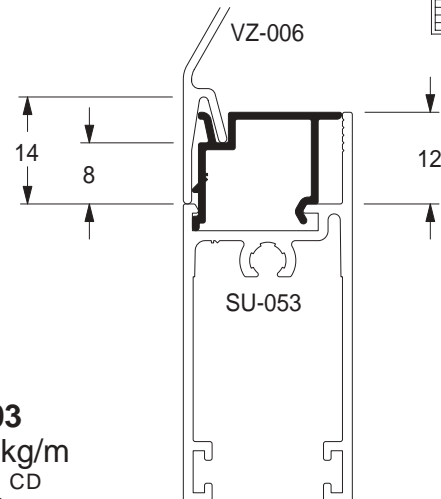
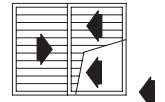

● **SU-203**  
 0,133 kg/m  
 Estoque CD  
 TUB ITS

Componente / marco

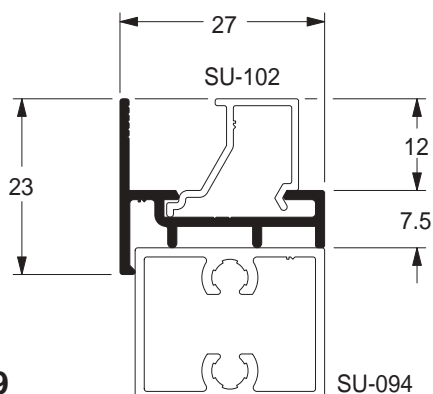
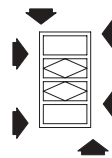

● **SU-099**  
 0,230 kg/m  
 Estoque CD  
 TUB ITS

Mata junta

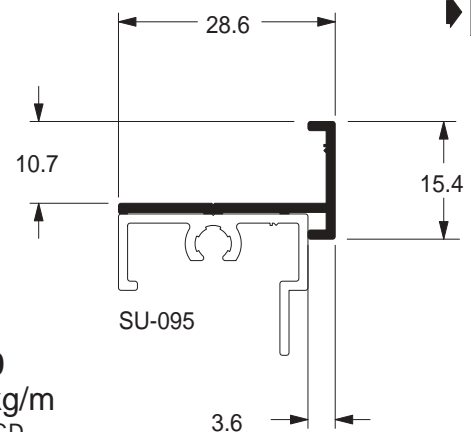
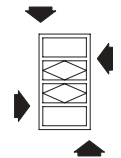

● **SU-100**  
 0,157 kg/m  
 Estoque CD  
 TUB ITS

Marco lateral

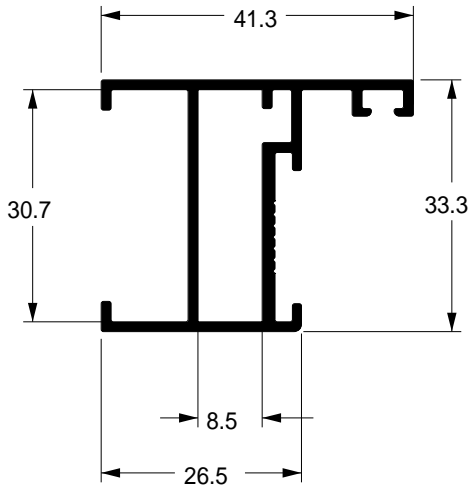
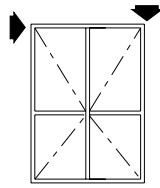

● **SU-279**  
 0,565 kg/m  
 Estoque CD  
 TUB ITS  
 ■ ■

Trilho superior

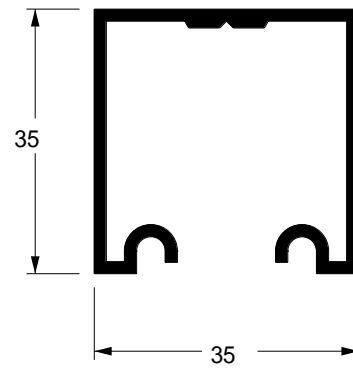
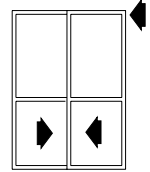

● **CX-1226**  
 0,567 kg/m  
 Estoque CD  
 TUB ITS  
 ■ □

Montante folha

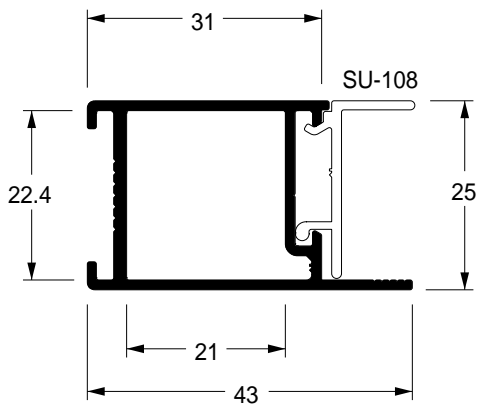
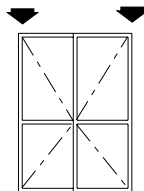

▲ **SU-120**  
 0,482 kg/m  
 Estoque CD  
 TUB ITS  
 ■ □

Travessa folha

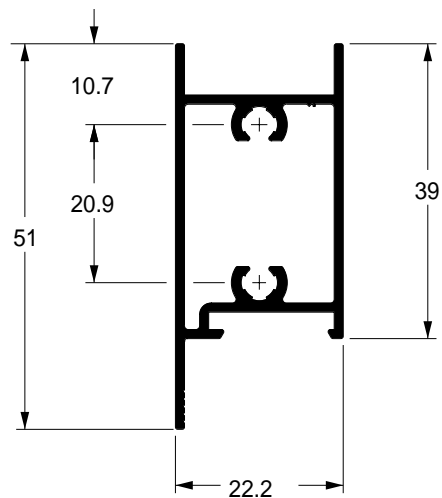
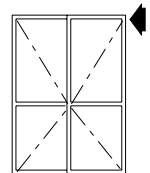

● **SU-110**  
 0,534 kg/m  
 Estoque CD  
 TUB ITS  
 ■ □



Montante folha

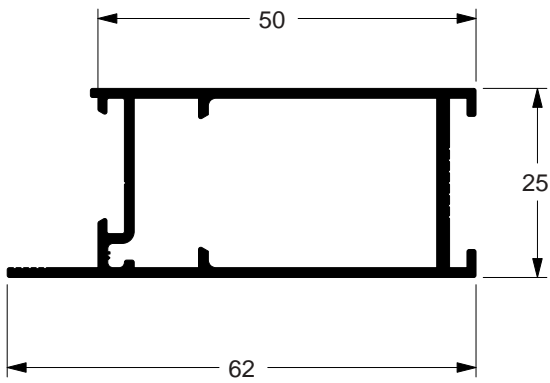
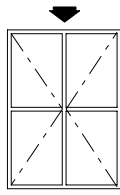

**SU-111**  
 0,640 kg/m

Estoque CD  
 TUB ITS

● ■ ■  
 ▲ ■ □

Montante folha sem baguete

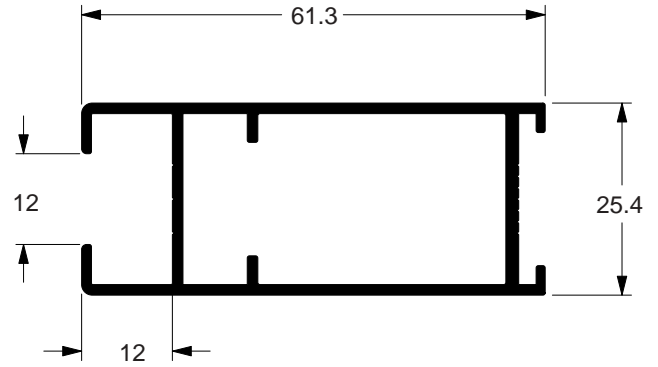
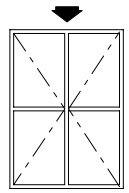

▲  
**SU-241**  
 0,734 kg/m

Estoque CD  
 TUB ITS

■ ■

Complemento folha

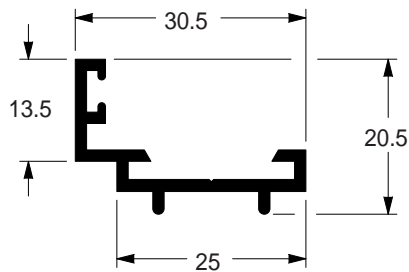
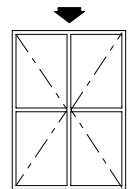

●  
**25-548**  
 0,283 kg/m

Estoque CD  
 TUB ITS

■ ■

Veneziana

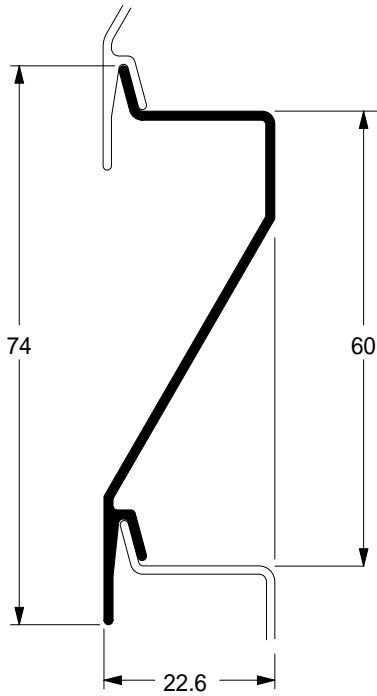

●  
**VZ-006**  
 0,326 kg/m  
 Estoque CD  
 TUB ITS  
 ■ □

Veneziana ventilada

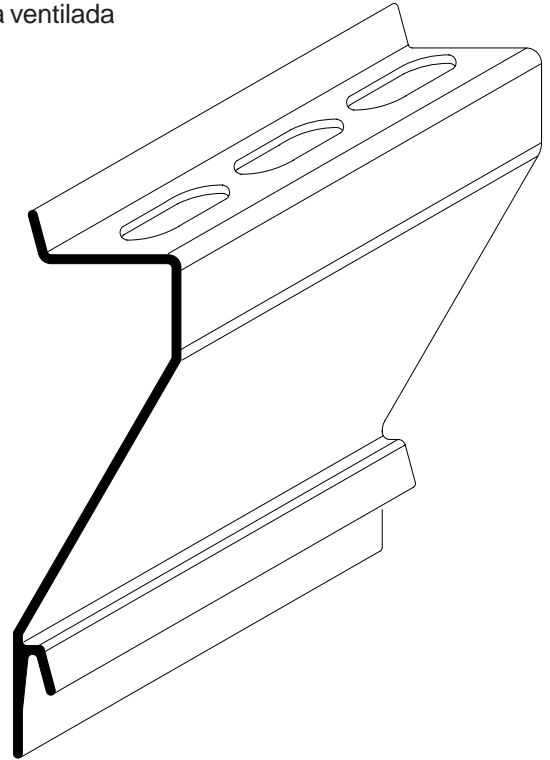

●  
**US-285**  
 0,326 kg/m  
 Estoque CD  
 TUB ITS  
 ■ □

Veneziana

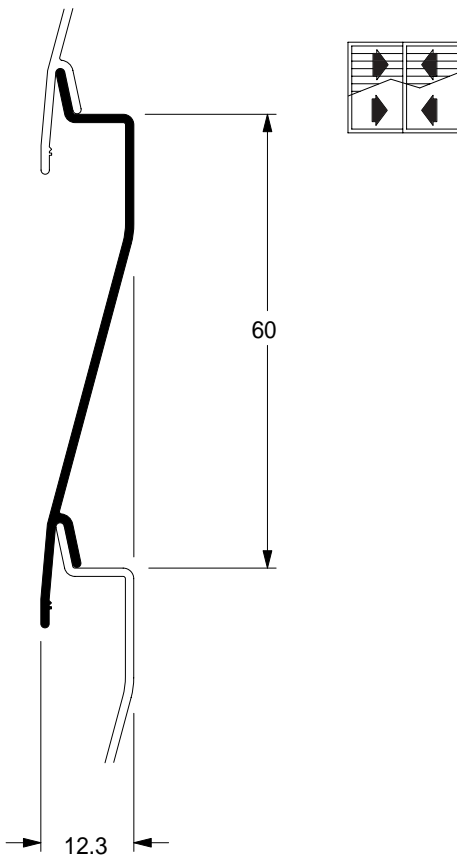

●  
**VZ-051**  
 0,268 kg/m  
 Estoque CD  
 TUB ITS  
 ■ □

Veneziana ventilada

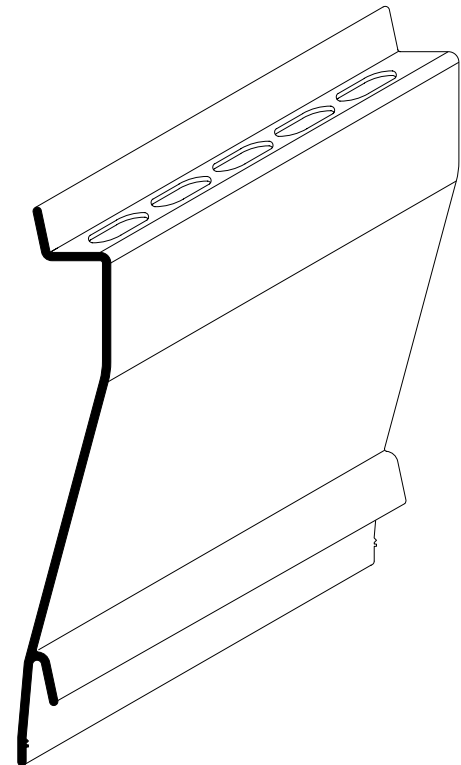

●  
**US-294**  
 0,268 kg/m  
 Estoque CD  
 TUB ITS  
 ■ □



## Capítulo 6

# Componentes

Código	Aplicação	Página
ALA-057	Alavanca com cavalete	97
BRA-702	Braço	93
BRA-703	Braço	93
BRA-705	Braço	93
BRA-725	Braço reforçado	93
CHU-787	Chumbador	99
CHU-838	Chumbador	99
CHU-840	Chumbador	99
CHU-864	Chumbador	99
CON-280	Concha simples	81
CON-295	Contratesta	95
CON-370	Contrafecho	83
CON-376	Fixador de travessa	94
CON-409	Contrafecho	82
DOB-837	Dobradiça	90
DOB-840	Dobradiça	96
FEC-009	Fecho direito para janela maxim-ar	91
FEC-010	Fecho direito para janela maxim-ar	91
FEC-011	Haste de comando	92
FEC-052	Concha lisa	84
FEC--055	Contrafecho	83
FEC-056	Fecho direito	77
FEC-057	Fecho direito	78
FEC-058	Fecho esquerdo	77
FEC-059	Haste de comando	92
FEC-060	Fecho esquerdo	78
FEC-338	Fecho tipo unha de sobrepor	97
FEC-636	Fecho-concha sem chave e trava reta	81
FEC-645	Fecho-concha com chave e trava reta	82
FEC-677	Fecho-concha com chave	84
FEC-695	Fecho duplo	89
FIT-206	Fita vedadora sem barreira plástica	100
FIT-212	Fita vedadora sem barreira plástica	100
FIT-246	Fita vedadora sem barreira plástica	100
FRA-820	Fechadura	85
FRA-822	Fechadura	95
GUA-007	Guarnição	102
GUA-053	Guarnição	102
GUA-157	Guarnição adesiva esponjosa	101

Código	Aplicação	Página
GUA-171	Guarnição adesiva esponjosa	101
GUA-172	Guarnição adesiva esponjosa	101
GUA-239	Guarnição	102
GUA-256	Guarnição	103
GUA-258	Guarnição adesiva esponjosa	101
GUA-259	Guarnição	103
GUA-282	Guarnição adesiva esponjosa	102
GUA-283	Guarnição	103
GUA-284	Guarnição	103
HAS-812	Haste de comando	89
MAC-927	Maçaneta com espelho	99
NYL-042	Botão tampa furo	102
NYL-190	Botão de fixação do remate	102
NYL-329	Vedador de vento	80
NYL-332	Guia deslizante	79
NYL-335	Vedador de vento	80
NYL-355	Recobrimento	94
NYL-356	Recobrimento	87
NYL-357	Recobrimento	87
NYL-363	Recobrimento para perfil SU-059 e SU-060	87
NYL-364	Recobrimento para perfil SU-061	88
NYL-414	Batedeira	88
NYL-416	Recobrimento da soleira	88
PAR-428	Parafuso 4.8 x 32mm cabeça panela	104
PAR-431	Parafuso 4.8 x 50mm cabeça panela	104
PAR-437	Parafuso 3.5 x 9.5mm cabeça panela	104
PAR-693	Parafuso cabeça panela 4.2 x25mm	105
PAR-694	Parafuso 4.2 x 32mm cabeça panela	105
PAR-936	Parafuso 4.2 x 16mm cabeça panela	104
PIV-752	Pivô da folha	94
PIV-753	Pivô para basculante	97
PRE-965	Presilha de remate	100
PUX-006	Puxador	85
REB-115	Rebite do repuxo 4 x 10.2mm	105
REB-117	Rebite do repuxo 3.2 x 10.2mm	105
ROL-426	Roldana com regulagem sem rolamento	79
ROL-439	Roldana dupla com rolamento e regulagem	86
ROL-440	Roldana com regulagem e rolamento	86
ROL-461	Roldana com regulagem sem rolamento	79

Produtos em estoque nestes Centros de Distribuição (CD):

TUB  Tubarão      ITS  Itapissuma

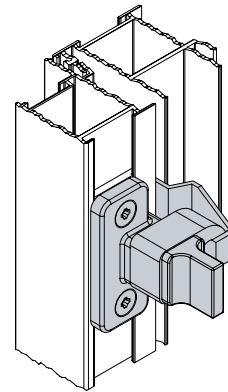
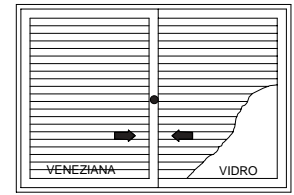
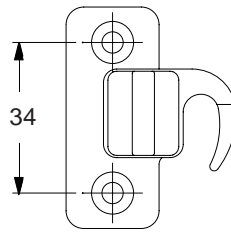
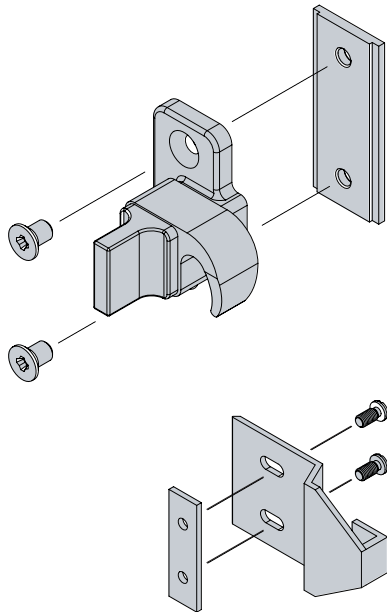

Aplicação

**FEC-056**

Fecho direito - Janela de correr  
 Acabamento: Alumínio preto  
 Embalagem: 1 peça

Estoque CD  
 TUB ITS  
 ■ ■

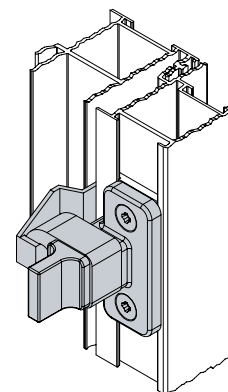
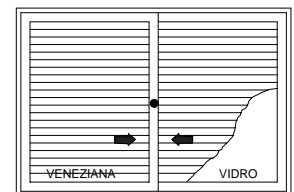
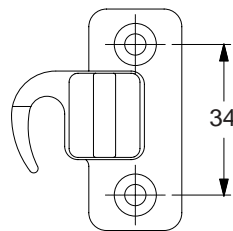
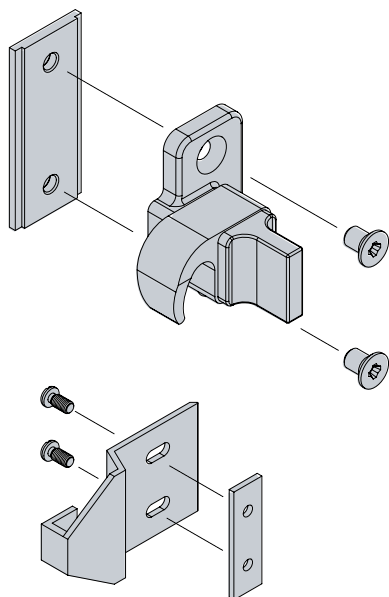

Aplicação

**FEC-058**

Fecho esquerdo - Janela de correr  
 Acabamento: Alumínio preto  
 Embalagem: 1 peça

Estoque CD  
 TUB ITS  
 □ ■

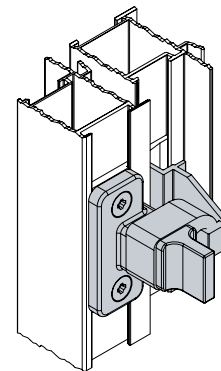
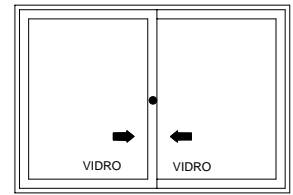
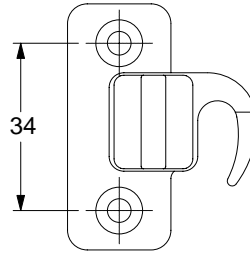
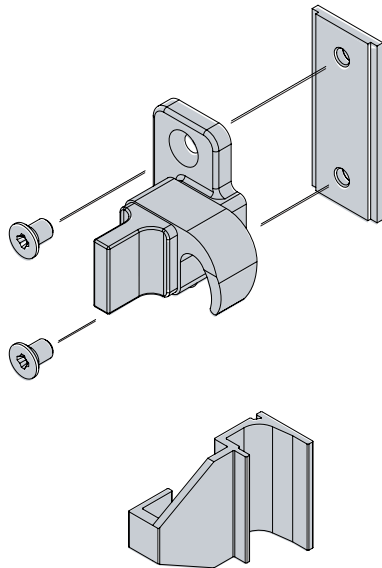

Aplicação

**FEC-057**

Fecho direito - Janela de correr  
 Acabamento: Alumínio preto  
 Embalagem: 1 peça

Estoque CD  
 TUB ITS

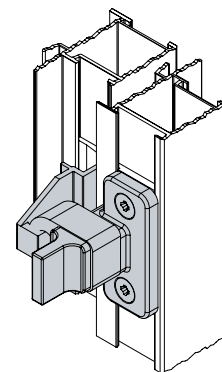
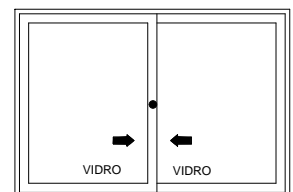
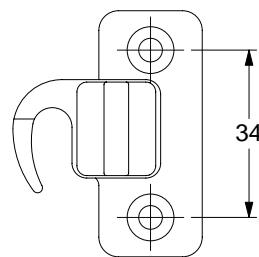
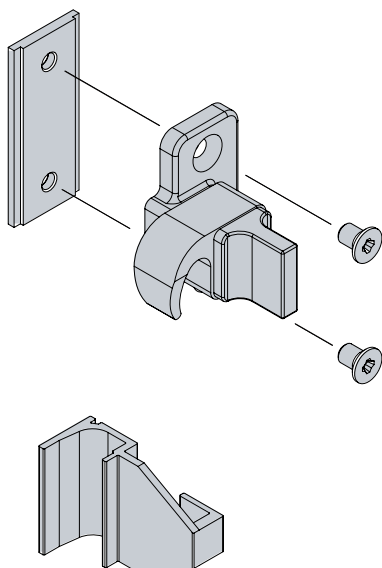

Aplicação

**FEC-060**

Fecho esquerdo - Janela de correr  
 Acabamento: Alumínio preto  
 Embalagem: 1 peça

Estoque CD  
 TUB ITS

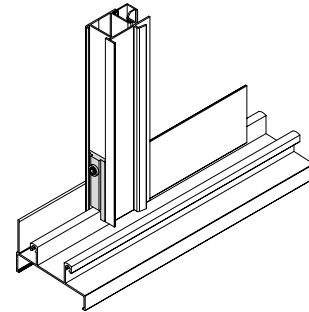
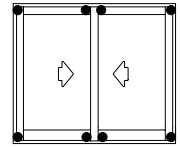
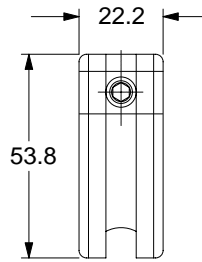
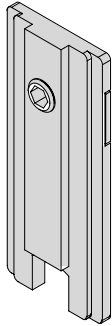

**NYL-332**

Guia deslizante - Janela e porta de correr  
 Acabamento: Nylon 6.6 preto  
 Embalagem: 20 peças

Aplicação

Estoque CD  
 TUB ITS  
 ■ ■

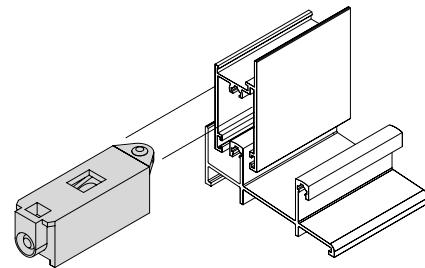
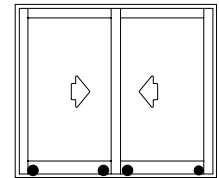
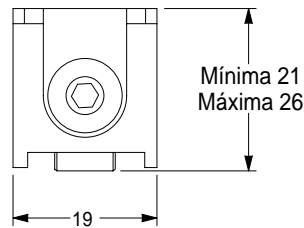
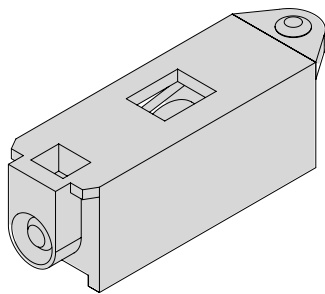

**ROL-426**

Roldana com regulagem sem rolamento - Janela de correr  
 Acabamento: Nylon 6.6 preto  
 Embalagem: 10 peças

Aplicação

Estoque CD  
 TUB ITS  
 ■ ■

Peso máximo por folha 15 kg

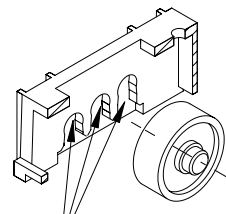
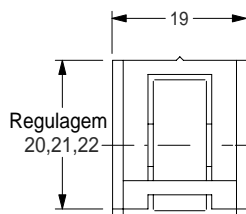
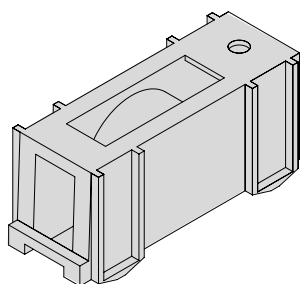

Regulagem com 3 estágios

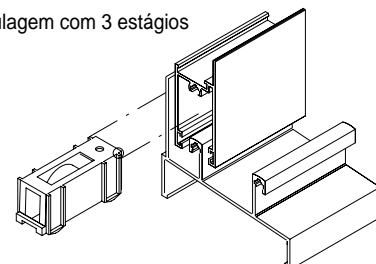
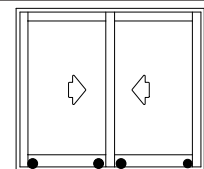

**ROL-461**

Roldana com regulagem sem rolamento - janela de correr  
 Acabamento: Nylon 6.6 preto  
 Embalagem: 10 peças

Aplicação

Estoque CD  
 TUB ITS  
 ■ ■

Peso máximo por folha 15 kg

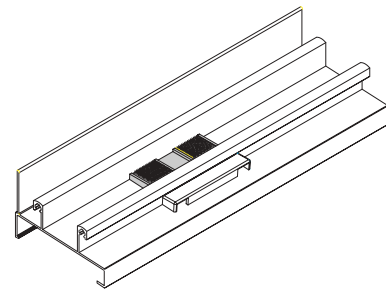
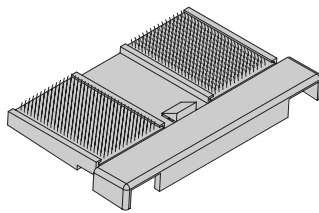
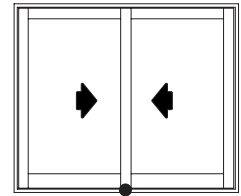
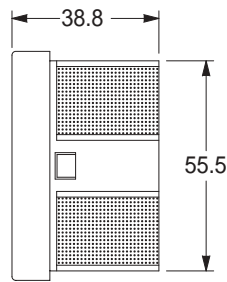

Aplicação

**NYL-329**

Caixa de dreno e vedador - Janela de correr  
 Acabamento: Nylon 6.6 preto  
 Embalagem: 10 peças

Estoque CD  
 TUB ITS  
 ■ ■

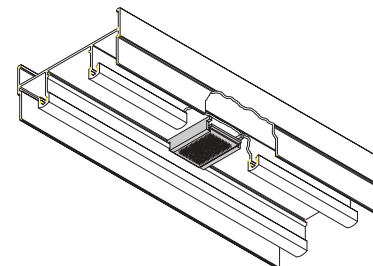
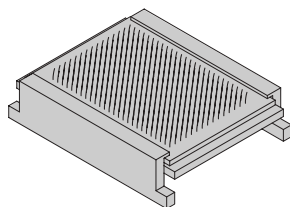
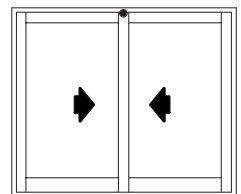
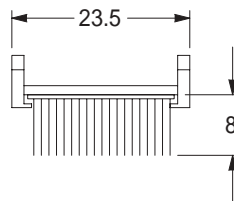

Aplicação

**NYL-335**

Vedador de vento - Janela de correr  
 Acabamento: Nylon 6.6 preto  
 Embalagem: 10 peças

Estoque CD  
 TUB ITS  
 ■ ■



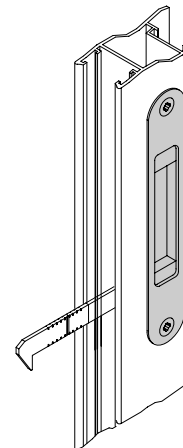
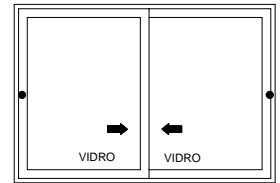
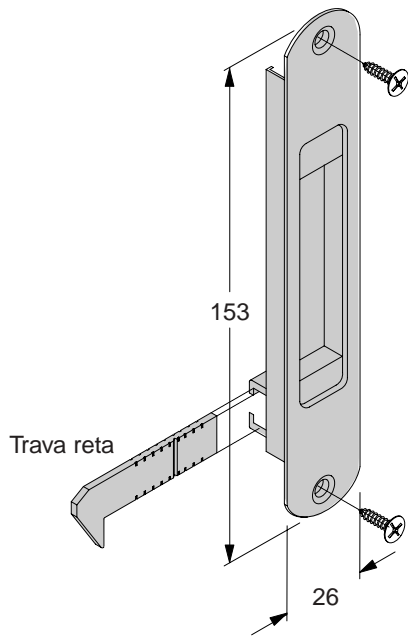

Aplicação

**FEC-636**

Fecho concha sem chave e trava reta - Janela e porta de correr

Acabamento: Alumínio preto

Embalagem: 1 peça

Estoque CD  
 TUB ITS  
 ■ ■

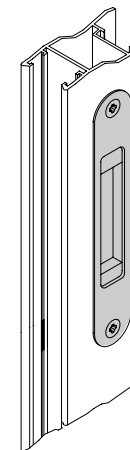
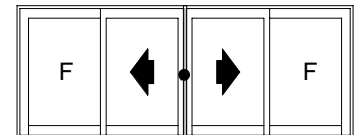
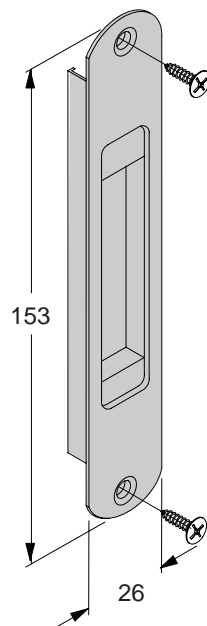

Aplicação

**CON-280**

Concha simples - Janela e porta de correr

Acabamento: Alumínio preto

Embalagem: 1 peça

Estoque CD  
 TUB ITS  
 ■ ■

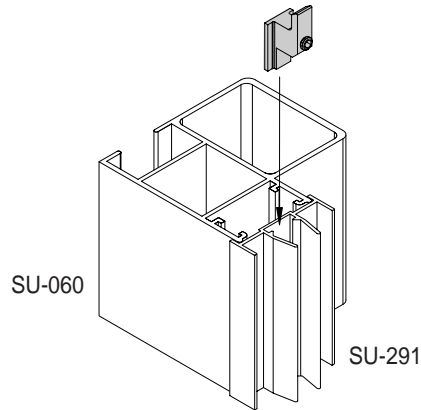
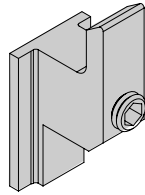
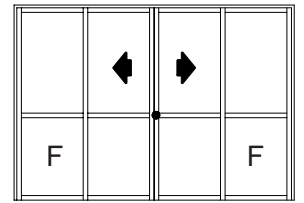
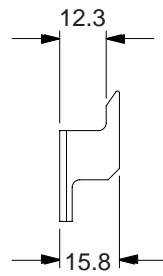

Aplicação

**CON-409**

Contrafecho para fechadura - Porta de correr  
 Acabamento: Zamak preto  
 Embalagem: 10 peças

Estoque CD  
 TUB ITS  
 ■ ■

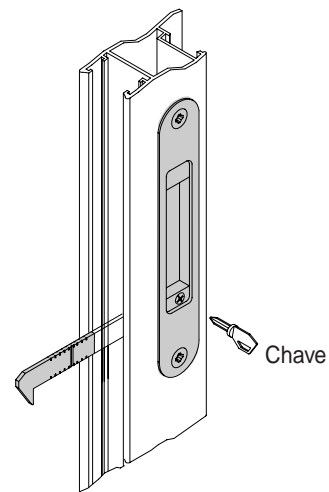
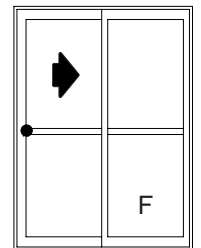
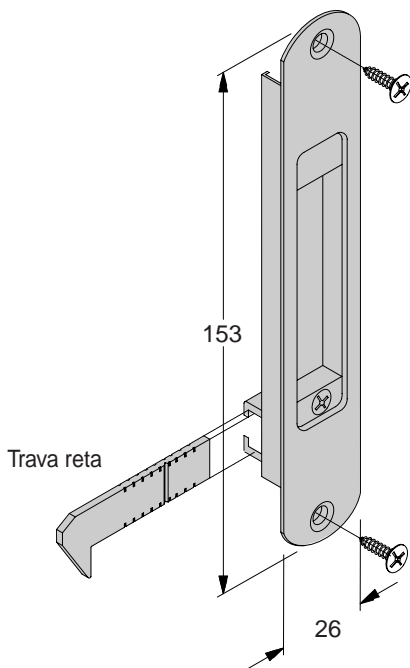

Aplicação

**FEC-645**

Fecho concha com chave e trava reta - Janela e porta de correr  
 Acabamento: Alumínio preto  
 Embalagem: 1 peça

Estoque CD  
 TUB ITS  
 ■ ■

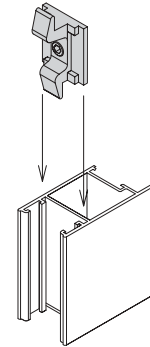
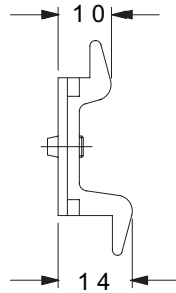
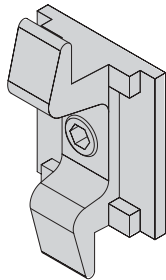

Aplicação

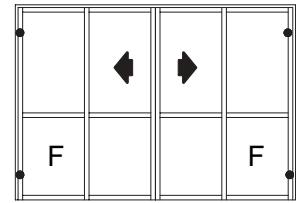

**FEC-055**

Contrafecho - Janela e porta de correr  
 Acabamento: Zamak preto  
 Embalagem: 10 peças

Estoque CD  
 TUB ITS  
 ■ ■

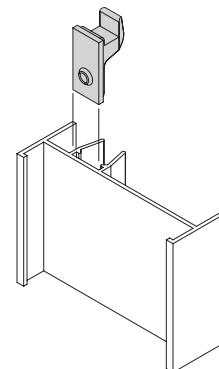
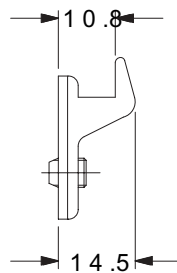
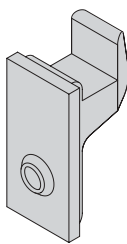

Aplicação

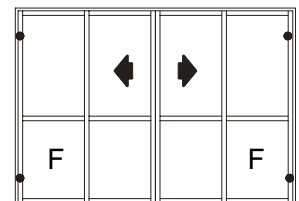

**CON-370**

Contrafecho - Janela e porta de correr  
 Acabamento: Zamak preto  
 Embalagem: 10 peças

Estoque CD  
 TUB ITS  
 ■ ■

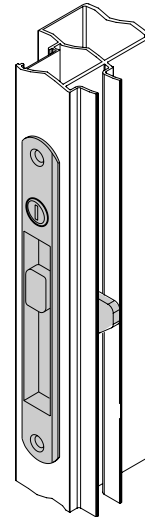
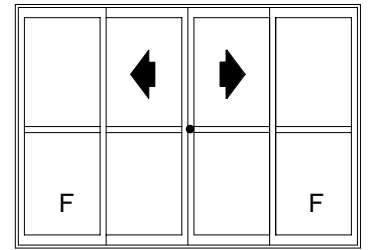
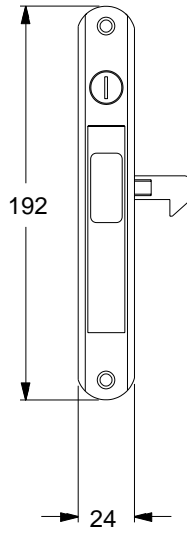
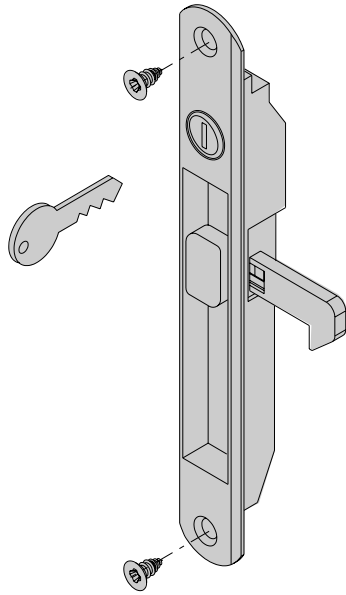

Aplicação

**FEC-677**

Fecho-concha com chave - Porta de correr  
 Acabamento: Alumínio preto  
 Embalagem: 1 peça

Estoque CD  
 TUB ITS

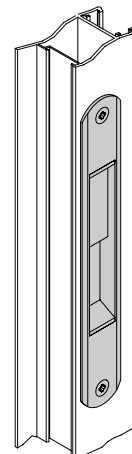
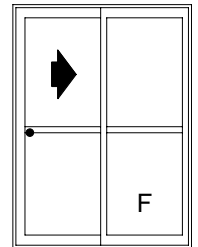
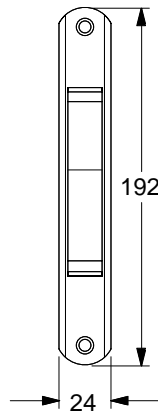
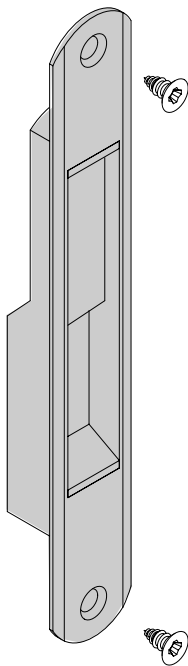

Aplicação

**FEC-052**

Concha lisa - Janela e porta de correr  
 Acabamento: Nylon preto  
 Embalagem: 1 peça

Estoque CD  
 TUB ITS

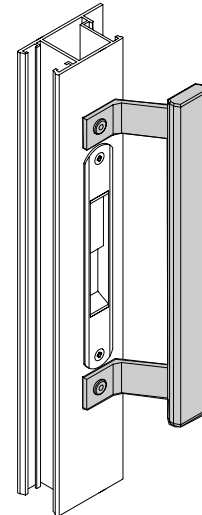
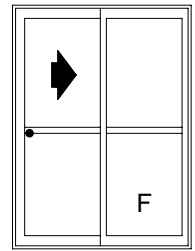
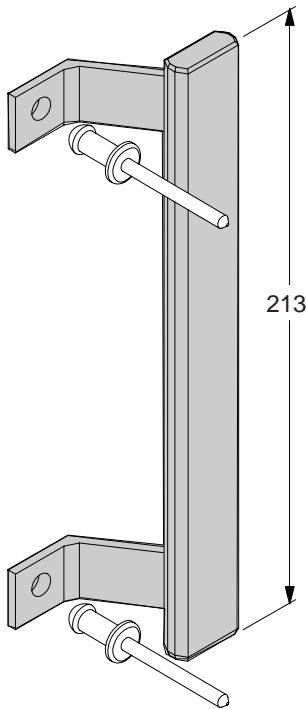

Aplicação

**PUX-006**

Puxador - Porta de correr  
 Acabamento: Alumínio preto  
 Embalagem: 1 peça

Estoque CD  
 TUB ITS  
 ■ ■

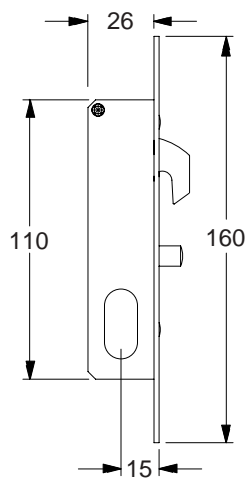
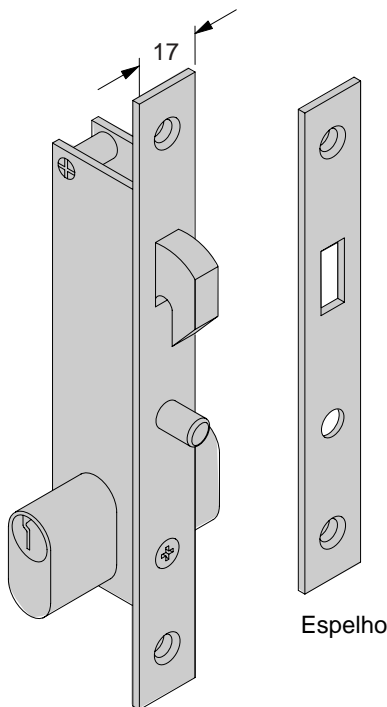

Espelho

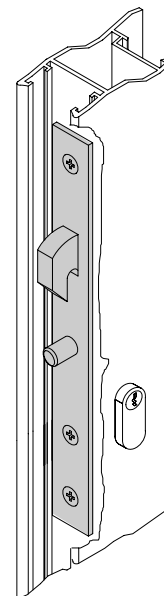
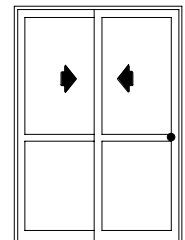

Aplicação

**FRA-820**

Fechadura - Porta de correr  
 Acabamento: Preto  
 Embalagem: 1 peça

Estoque CD  
 TUB ITS  
 ■ ■

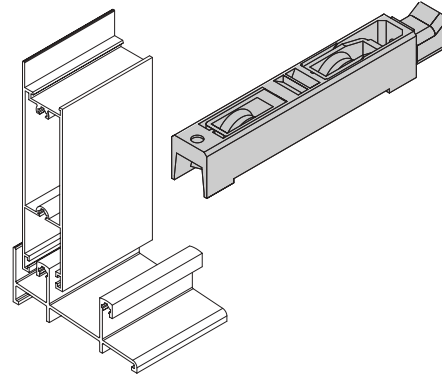
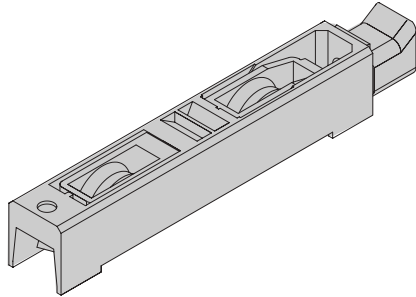
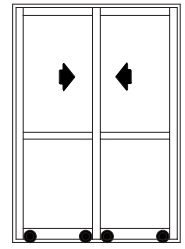
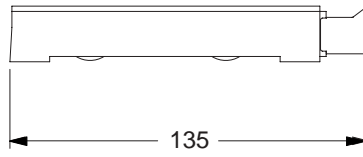

Aplicação

**ROL-439**

Roldana dupla com rolamento e regulagem - Porta de correr  
 Acabamento: Nylon  
 Embalagem: 2 peças

Carga máxima por folha 80 kg

Estoque CD  
 TUB ITS

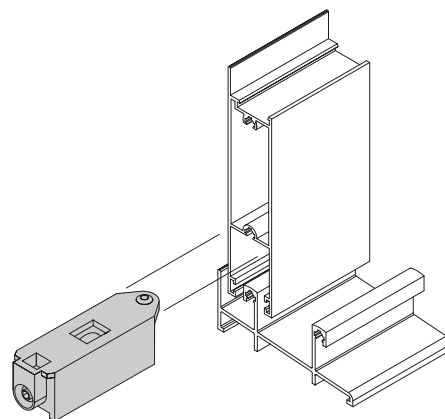
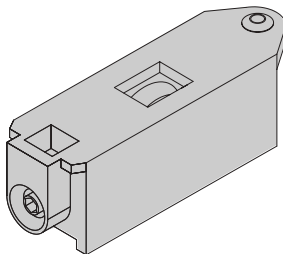
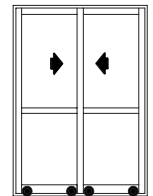
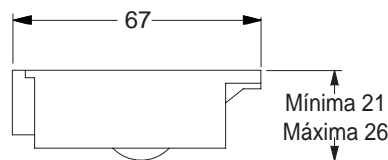

Aplicação

**ROL-440**

Roldana com regulagem e rolamento - Porta de correr  
 Acabamento: Nylon 6.6 preto  
 Embalagem: 10 peças

Carga máxima por folha 40 kg

Estoque CD  
 TUB ITS

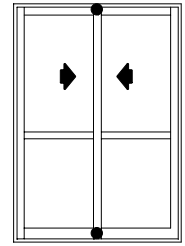
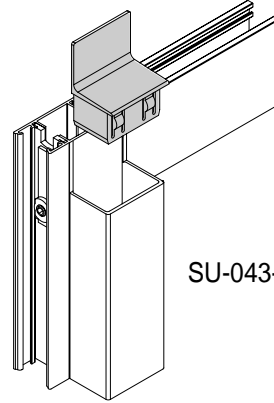
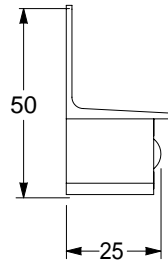
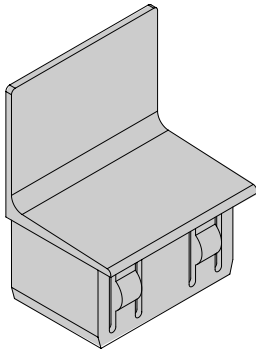

SU-043-044

**NYL-356**

Recobrimento - Porta de correr  
 Acabamento: Nylon 6.6 preto  
 Embalagem: 20 peças

Aplicação

Estoque CD  
 TUB ITS  
 ■ ■

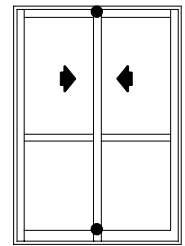
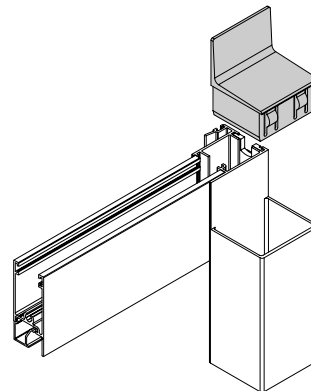
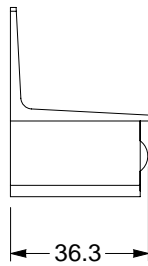
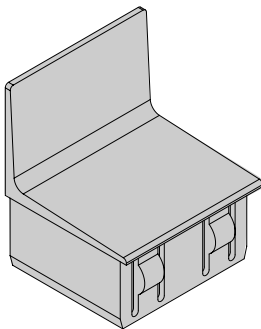

SU-047-049

**NYL-357**

Recobrimento - Porta de correr  
 Acabamento: Nylon 6.6 preto  
 Embalagem: 20 peças

Aplicação

Estoque CD  
 TUB ITS  
 ■ ■

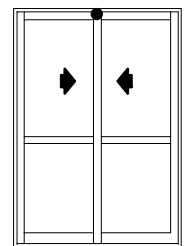
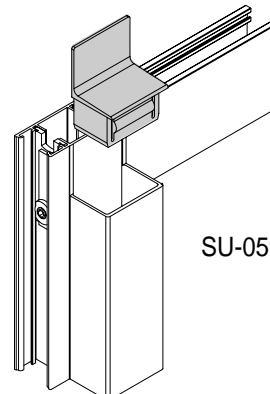
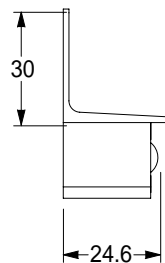
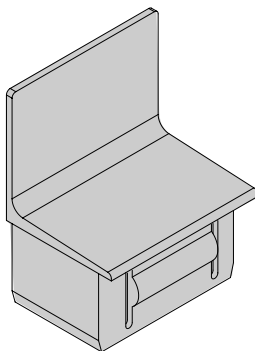

SU-059-060

**NYL-363**

Recobrimento - Porta de correr  
 Acabamento: Nylon 6.6 preto  
 Embalagem: 20 peças

Aplicação

Estoque CD  
 TUB ITS  
 ■ ■

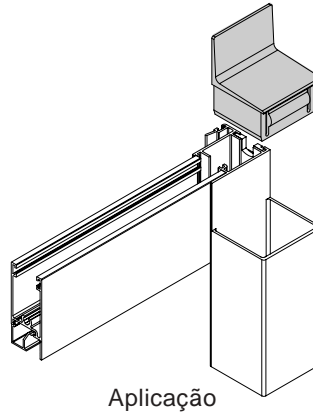
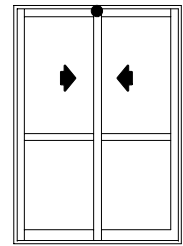
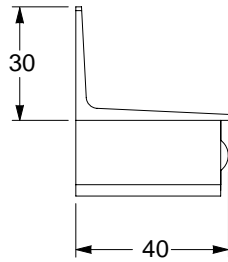
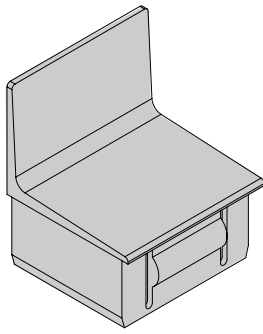

SU-061

Aplicação

Estoque CD  
 TUB ITS  
 ■ ■

**NYL-364**

Recobrimento - Porta de correr  
 Acabamento: Nylon 6.6 preto  
 Embalagem: 20 peças

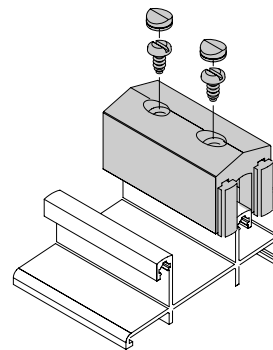
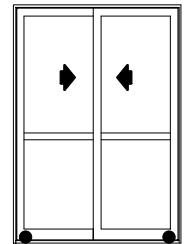
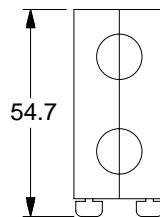
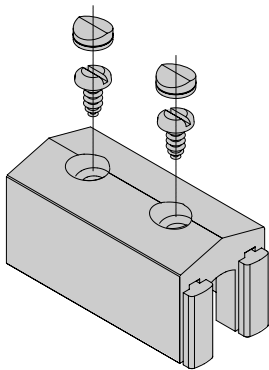

Aplicação

Estoque CD  
 TUB ITS  
 ■ □

**NYL-414**

Batedeira - Janela e porta de correr  
 Acabamento: Nylon 6.6 preto  
 Embalagem: 10 peças

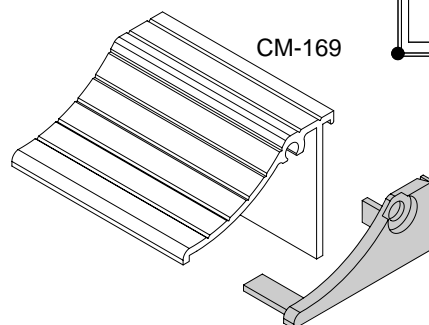
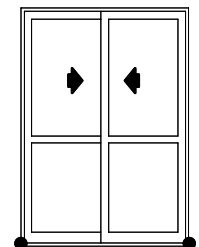
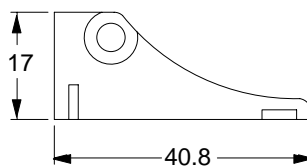
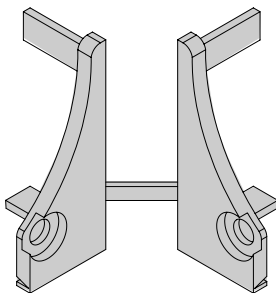

CM-169

Aplicação

Estoque CD  
 TUB ITS  
 ■ □

**NYL-416**

Recobrimento da soleira - Porta de correr  
 Acabamento: Nylon 6.6 preto  
 Embalagem: 10 peças com parafuso



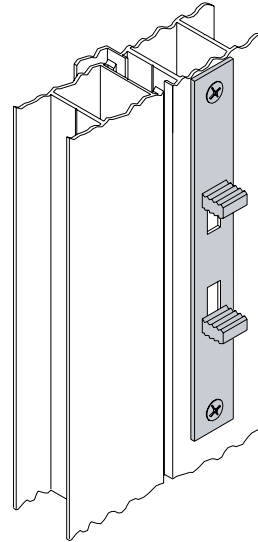
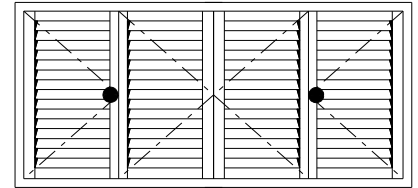
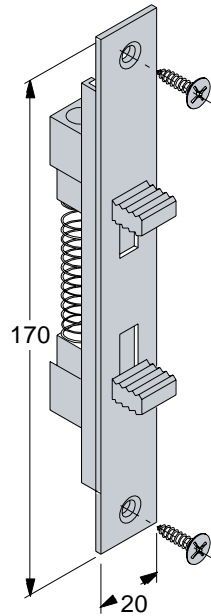

Aplicação

**FEC-695**

Fecho duplo - Janela camarão  
 Acabamento: Alumínio preto / Nylon 6.6  
 Embalagem: 1 peça com parafusos

Estoque CD  
 TUB ITS

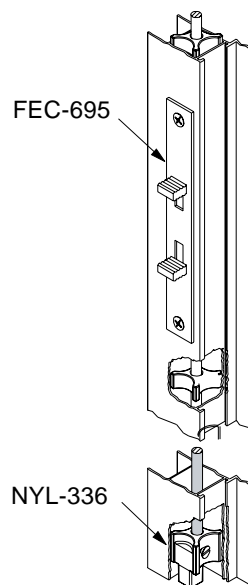
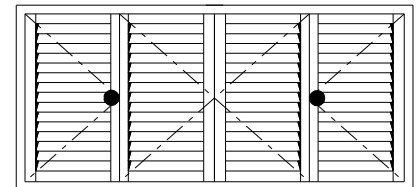
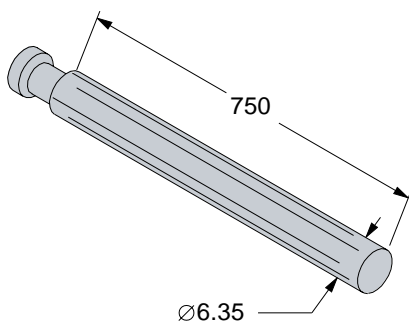

Aplicação

**HAS-812**

Haste de comando - Janela camarão  
 Acabamento: Alumínio natural  
 Embalagem: 10 peças

Estoque CD  
 TUB ITS

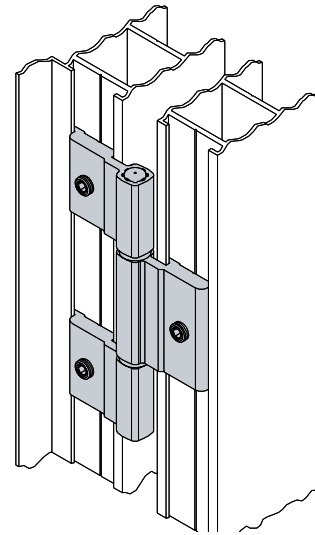
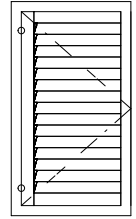
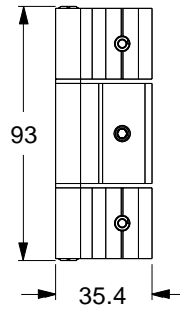
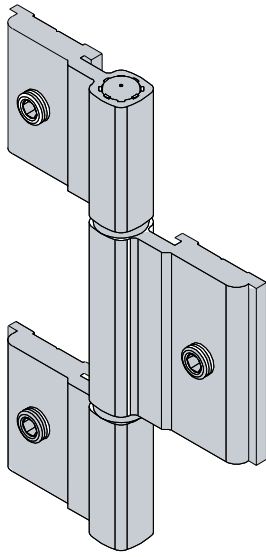

Aplicação

## DOB-837

Dobradiça - Portinhola  
Acabamento: Preto  
Embalagem: 2 peças

Estoque CD  
TUB ITS  
■ □

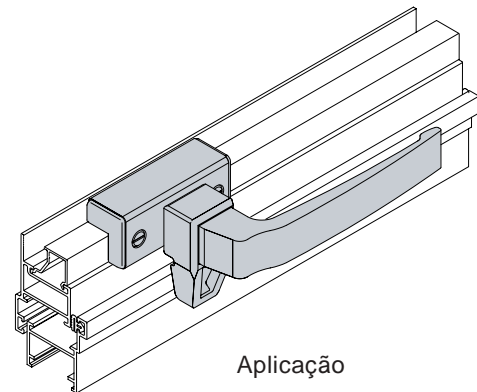
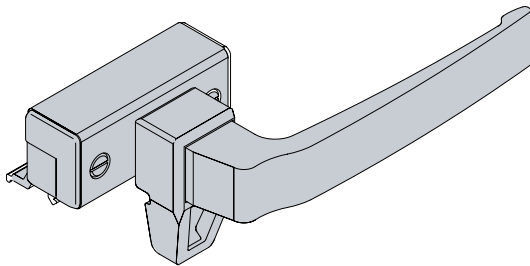
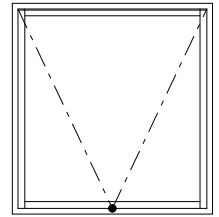
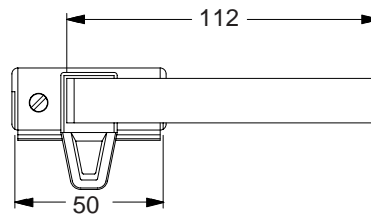

Aplicação

**FEC-009**

Fecho direito - Janela maxim-ar  
 Acabamento: Preto  
 Embalagem: 1 peça

Estoque CD  
 TUB ITS  
 ■ ■

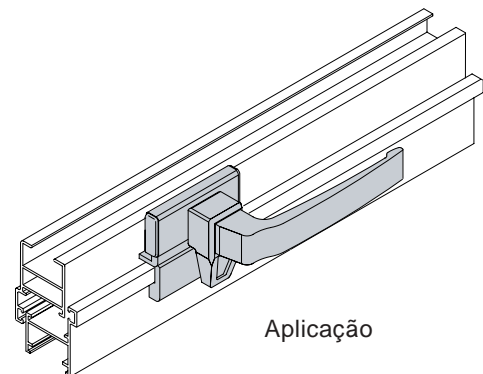
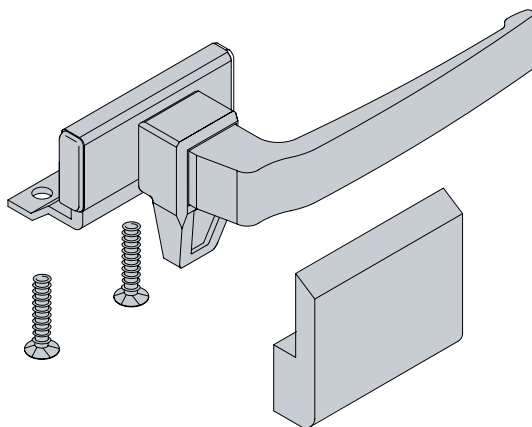
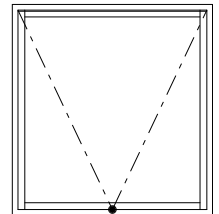
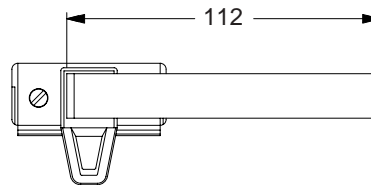

Aplicação

**FEC-010**

Fecho direito - Janela maxim-ar sem baguete  
 Acabamento: Preto  
 Embalagem: 1 peça

Estoque CD  
 TUB ITS  
 ■ ■

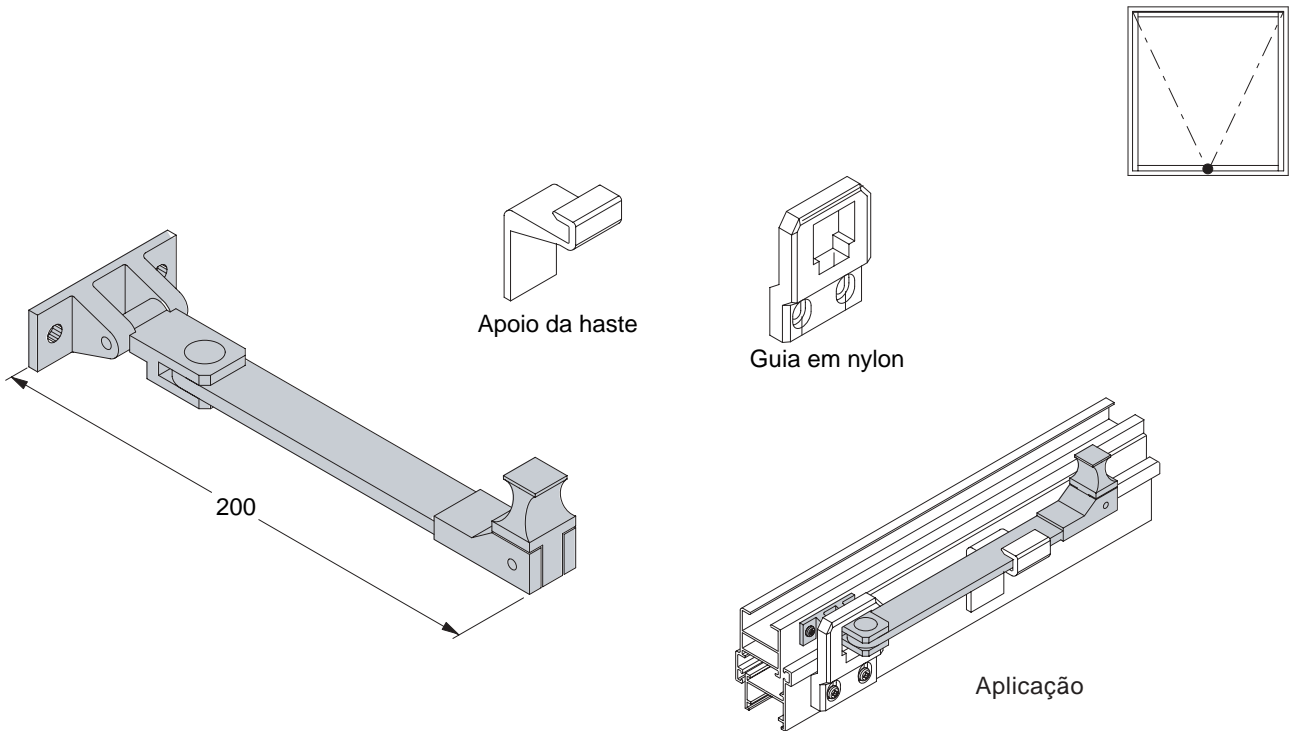

**FEC-011**

Haste de comando - Janela maxim-ar  
 Acabamento: Alumínio preto / Nylon  
 Embalagem: 1 peça

Estoque CD  
 TUB ITS  
 ■ □

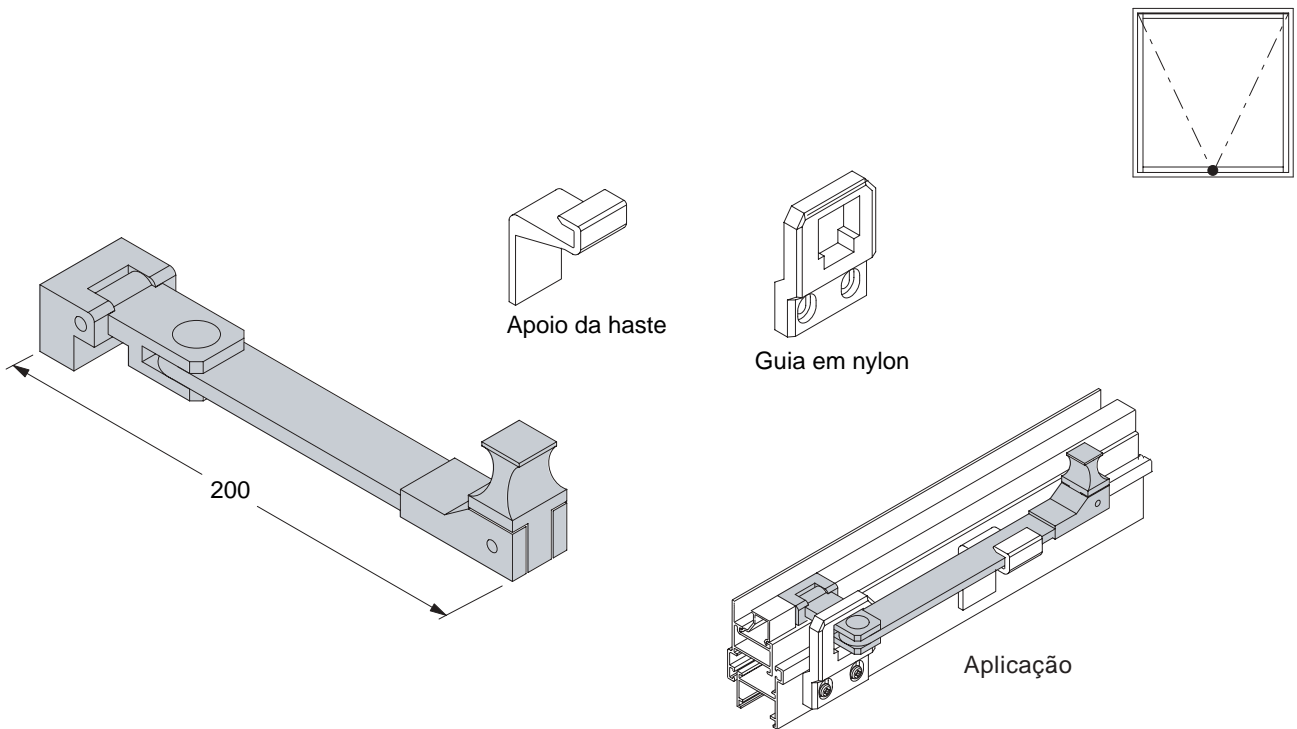

**FEC-059**

Haste de comando - Janela maxim-ar  
 Acabamento: Alumínio preto / Nylon  
 Embalagem: 1 peça

Estoque CD  
 TUB ITS  
 ■ □

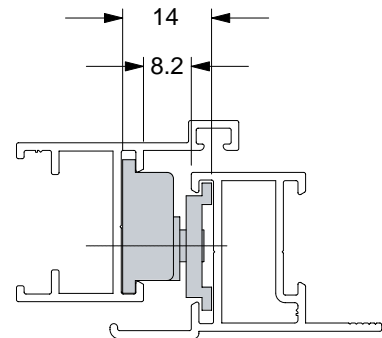
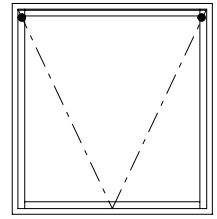
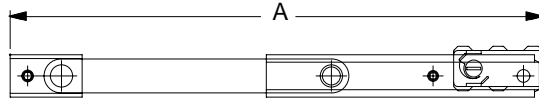
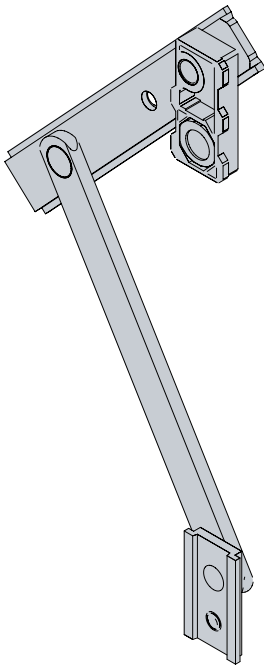

Aplicação

Código	Dimensões (mm)	Altura da folha (mm)	
	(A)	Mínimo	Máximo
<b>BRA-705</b>	250	270	500
<b>BRA-702</b>	500	510	760
<b>BRA-703</b>	750	770	900

Acabamento: Alumínio preto  
Embalagem: 1 par

Estoque CD  
TUB ITS  
■ ■

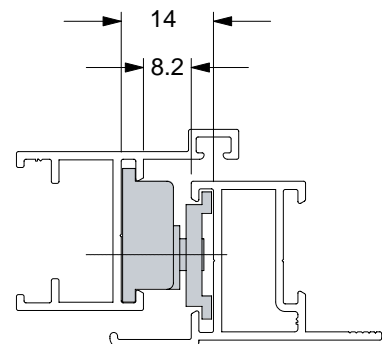
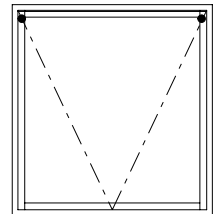
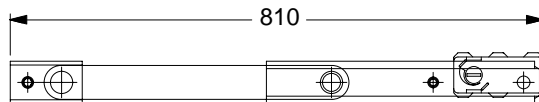
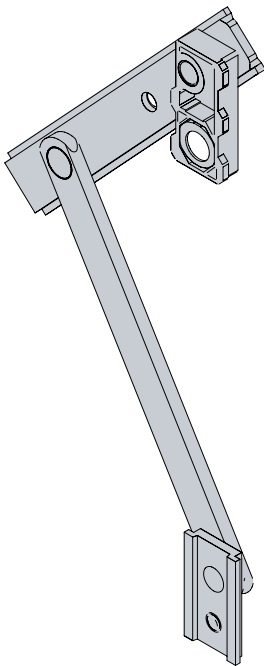

Aplicação

Braço reforçado

Código	Dimensões (mm)	Altura da folha (mm)	
	(A)	Mínimo	Máximo
<b>BRA-725</b>	810	900	1200

Acabamento: Alumínio preto  
Embalagem: 1 par

Estoque CD  
TUB ITS  
■ ■

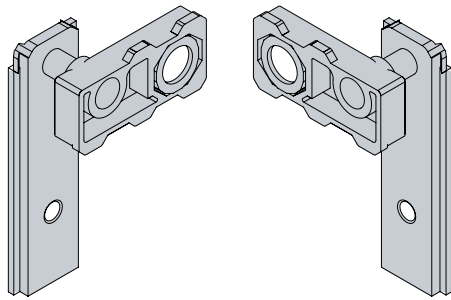

Esquerda

Direita

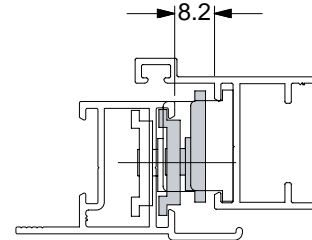
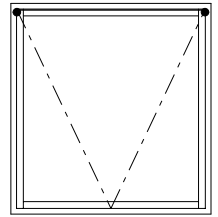
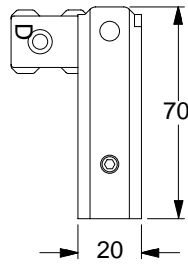

Aplicação

Estoque CD  
 TUB ITS  
 ■ ■

**PIV-752**

Pivô da folha - Janela projetante  
 Acabamento: Alumínio preto / Nylon  
 Embalagem: 1 par

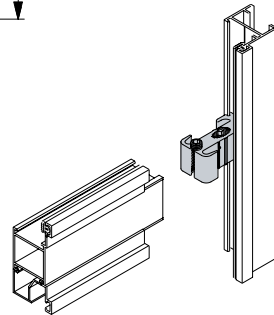
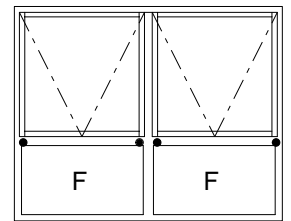
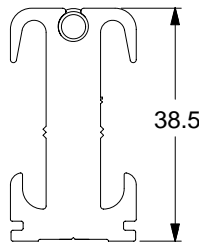
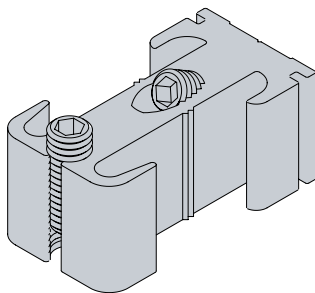

Aplicação

Estoque CD  
 TUB ITS  
 ■ ■

**CON-376**

Fixador de travessa - Janela maxim-ar  
 Acabamento: Natural  
 Embalagem: 10 peças

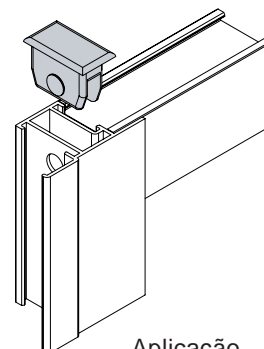
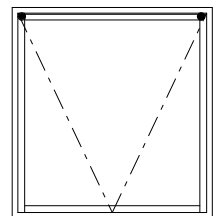
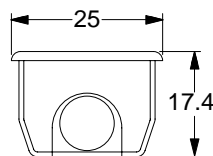
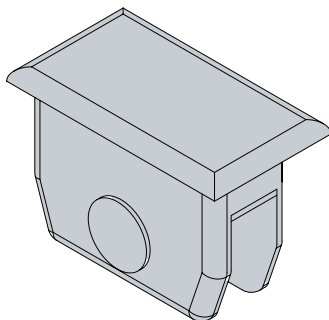

Aplicação

Estoque CD  
 TUB ITS  
 ■ ■

**NYL-355**

Recobrimento - Janela maxim-ar 90°  
 Acabamento: Nylon 6.6 preto  
 Embalagem: 100 peças

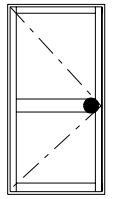
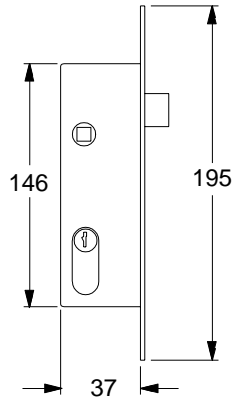
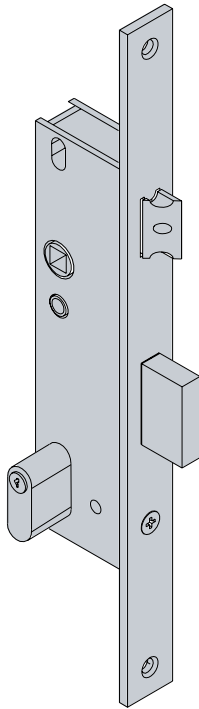

**FRA-822**

Fechadura - Porta de giro  
 Acabamento: Latão fumê  
 Embalagem: 1 peça

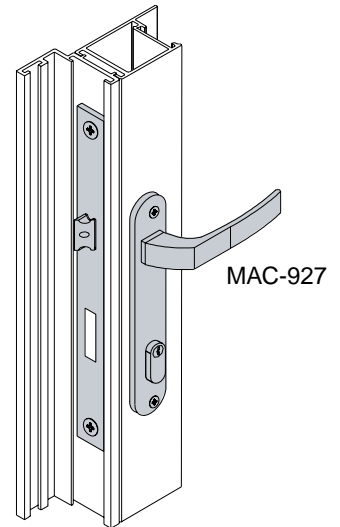

MAC-927

Aplicação

Estoque CD  
 TUB ITS  
 ■ ■

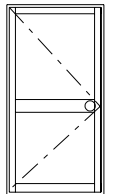
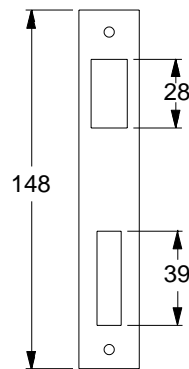
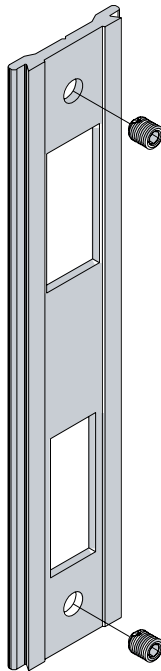

**CON-295**

Contra testa - Porta de giro  
 Acabamento: Alumínio preto  
 Embalagem: 2 peças

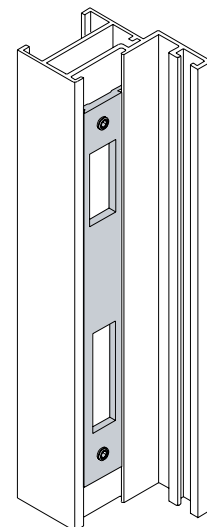

Aplicação

Estoque CD  
 TUB ITS  
 ■ □

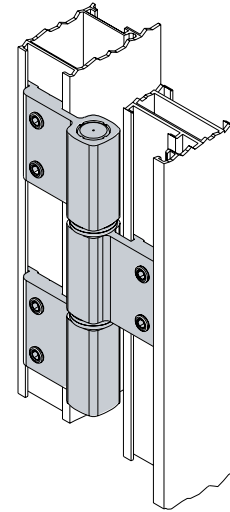
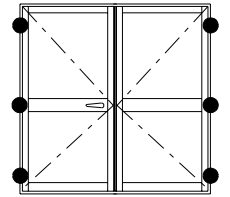
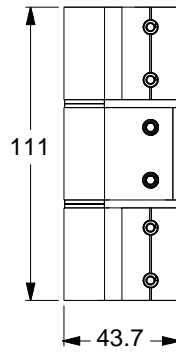
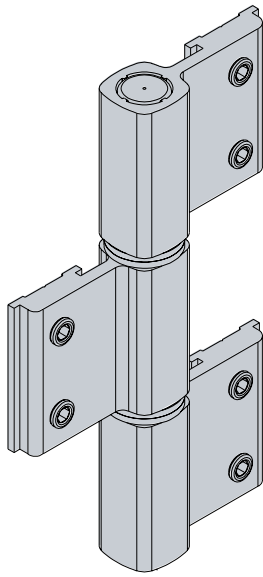

Aplicação

**DOB-840**

Dobradiça - Porta de giro  
 Acabamento: Preto  
 Embalagem: 3 peças

Estoque CD  
 TUB ITS  
 ■ ■

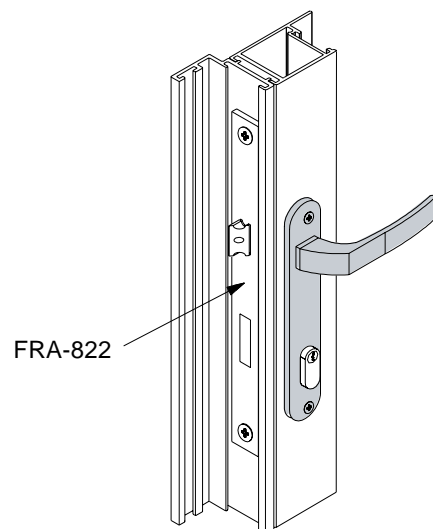
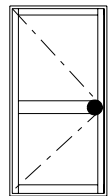
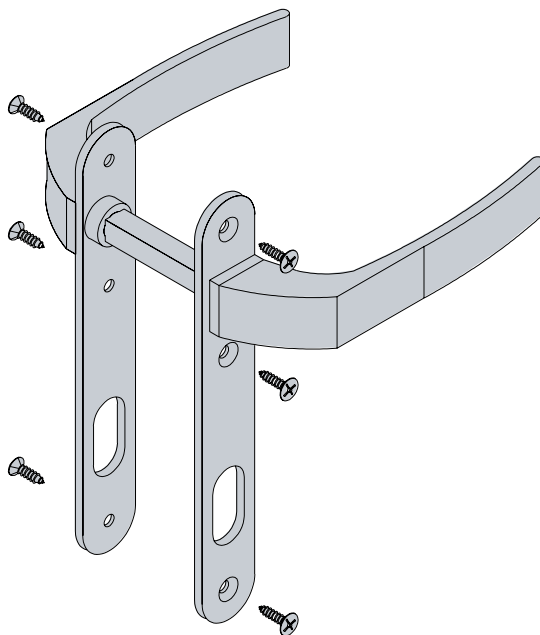

Aplicação

**MAC-927**

Maçaneta com espelho - Porta de giro  
 Acabamento: Preto  
 Embalagem: 1 peça

Estoque CD  
 TUB ITS  
 ■ ■



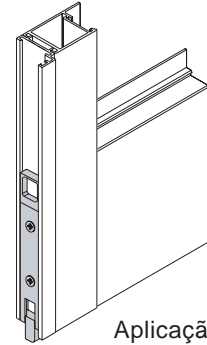
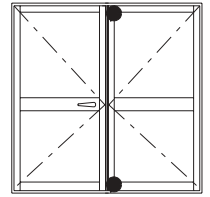
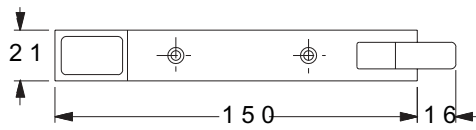
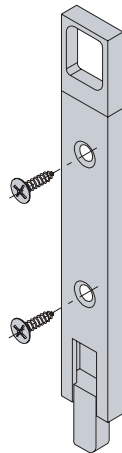

Aplicação

Estoque CD  
 TUB ITS

**FEC-338**

Fecho tipo unha de sobrepor - Porta de giro  
 Acabamento: Alumínio / Nylon  
 Embalagem: 1 peça

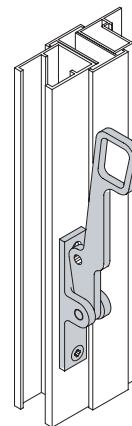
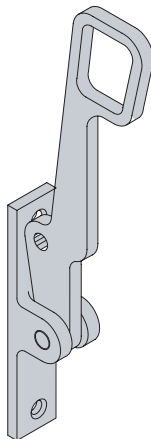

Aplicação

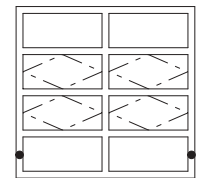

Estoque CD  
 TUB ITS

**ALA-057**

Alavanca com cavalete - Janela basculante  
 Acabamento: Alumínio preto  
 Embalagem: 1 peça

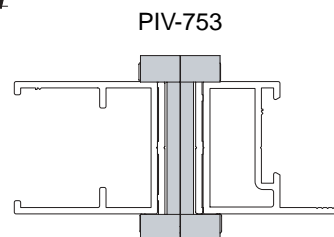
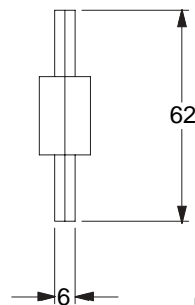
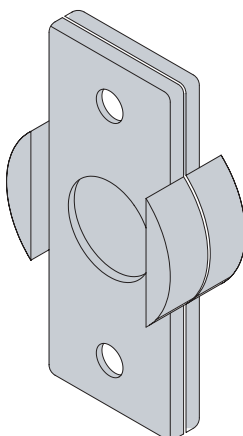

PIV-753

Aplicação

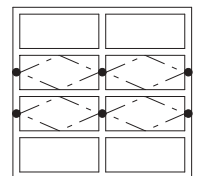

Estoque CD  
 TUB ITS

**PIV-753**

Pivô - Janela basculante  
 Acabamento: Nylon 6.6 preto  
 Embalagem: 10 peças

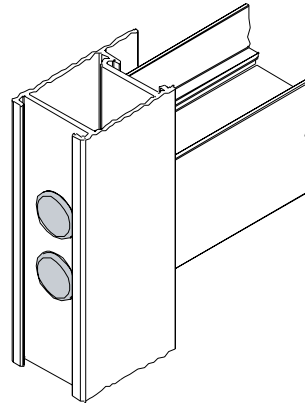
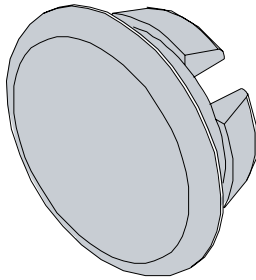
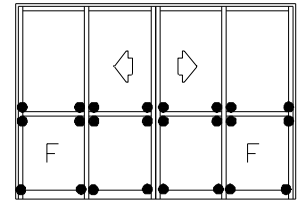
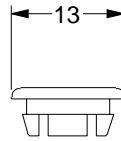

Aplicação

**NYL-042**

Botão tampa furo - Janela e porta de correr  
 Acabamento: Nylon 6.6 preto  
 Embalagem: 1.000 peças

Estoque CD  
 TUB ITS  
 ■ ■

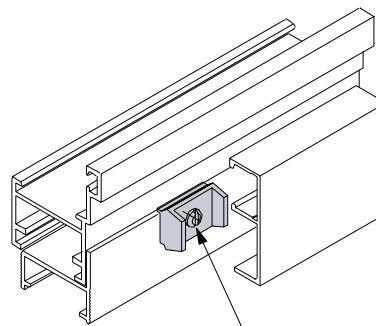
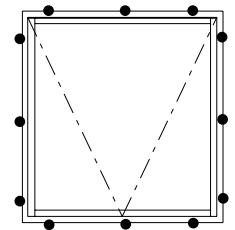
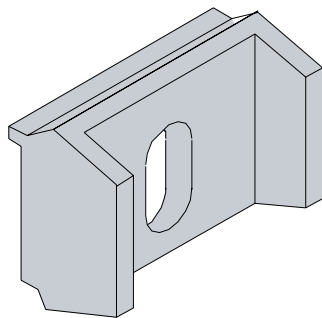

MP-347

PAR-936

Aplicação

**NYL-190**

Botão de fixação do remate - Janela e porta  
 Acabamento: Nylon 6.6 preto  
 Embalagem: 500 peças

Estoque CD  
 TUB ITS  
 ■ ■

Perfil base CM-093

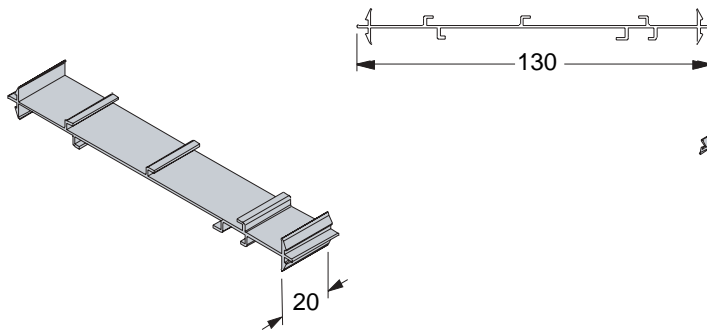

**CHU-838**

Chumbador - Contramarco  
 Acabamento: Alumínio natural  
 Embalagem: 50 peças

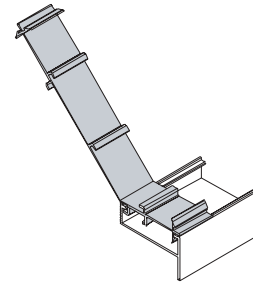

Aplicação

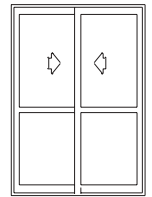

Perfil CM-200

Estoque CD  
 TUB ITS

Perfil base CM-099

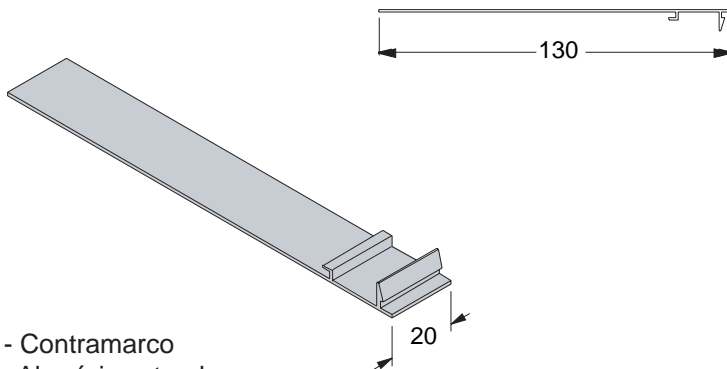

**CHU-840**

Chumbador - Contramarco  
 Acabamento: Alumínio natural  
 Embalagem: 50 peças

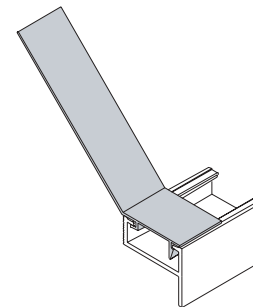

Aplicação

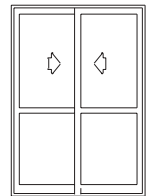

Perfil CM-200

Estoque CD  
 TUB ITS

Perfil base CM-124

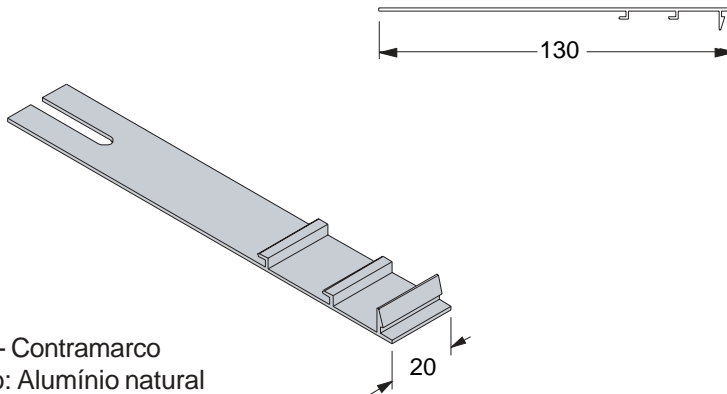

**CHU-864**

Chumbador - Contramarco  
 Acabamento: Alumínio natural  
 Embalagem: 50 peças

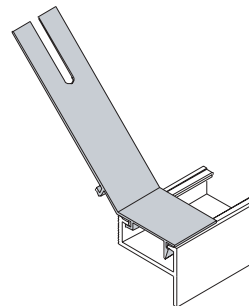

Aplicação

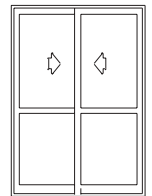

Perfil CM-060/098/200

Estoque CD  
 SBA TUB ITS

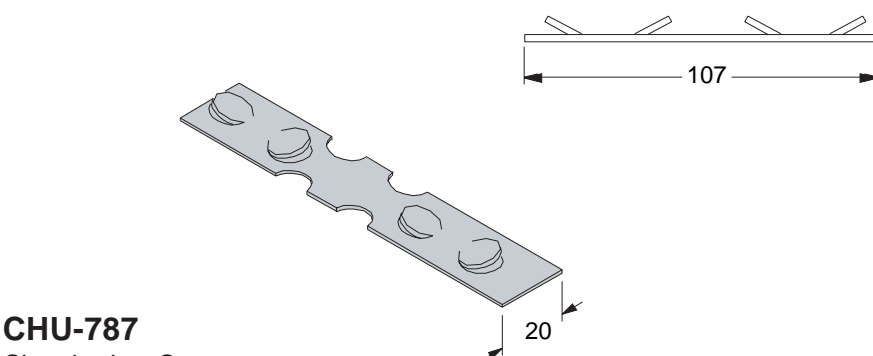

**CHU-787**

Chumbador - Contramarco  
 Acabamento: Aço zincado  
 Embalagem: 50 peças

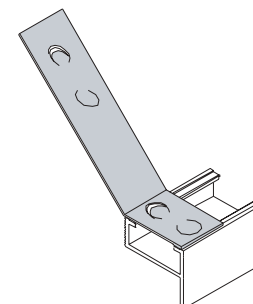

Aplicação

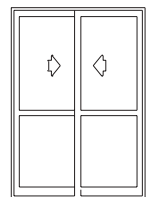

Perfil CM-060/200

Estoque CD  
 SBA TUB ITS

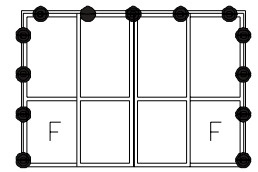
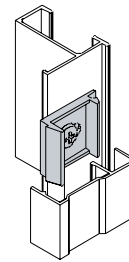
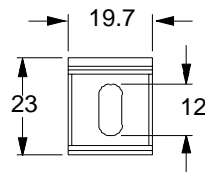
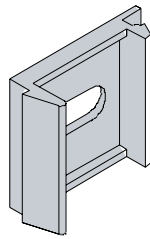

**PRE-965**

Presilha do remate - Contramarco  
 Acabamento: Nylon 6.6 preto  
 Embalagem: 100 peças

Aplicação

Estoque CD  
 TUB ITS

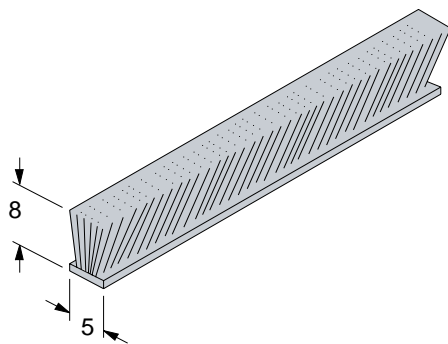

**FIT-212**

Fita vedadora sem barreira plástica  
 Acabamento: Preto  
 Embalagem: 50 metros

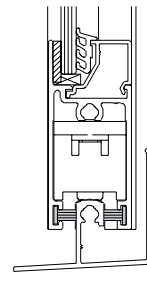

Aplicação

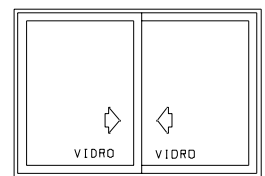

Estoque CD  
 TUB ITS

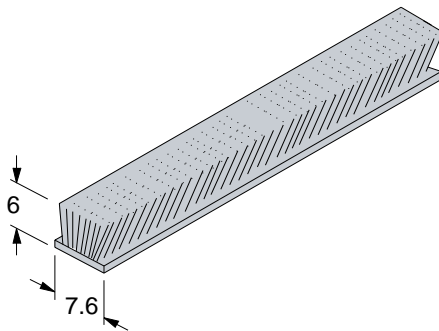

**FIT-246**

Fita vedadora sem barreira plástica  
 Acabamento: Preto  
 Embalagem: 50 metros

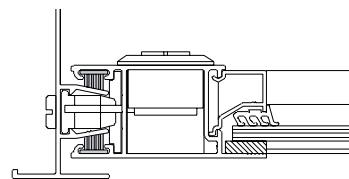

Aplicação

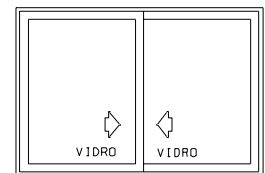

Estoque CD  
 TUB ITS

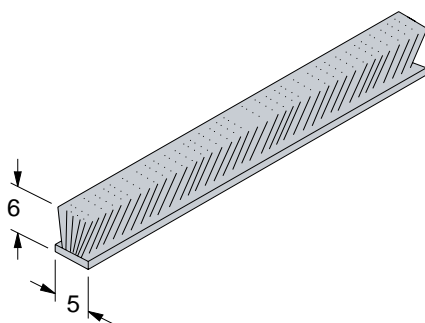

**FIT-206**

Fita vedadora sem barreira plástica  
 Acabamento: Preto  
 Embalagem: 50 metros

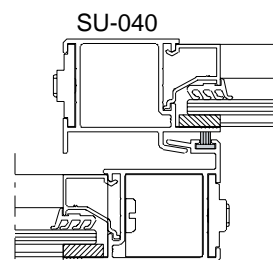

Aplicação

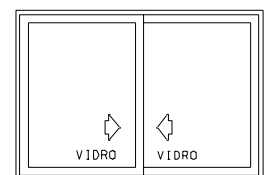

Estoque CD  
 TUB ITS

**GUA-172**

Guarnição adesiva esponjosa  
 Acabamento: Preto  
 Embalagem: 61 metros

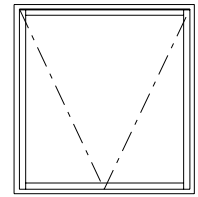
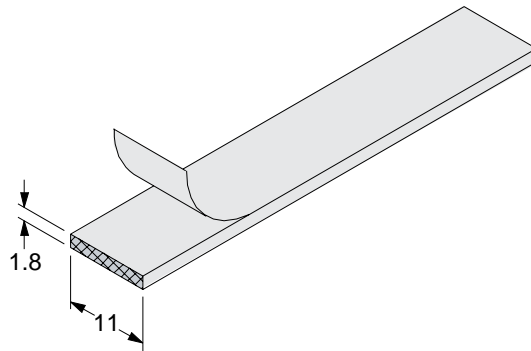

Estoque CD  
 TUB ITS



**GUA-171**

Guarnição adesiva esponjosa  
 Acabamento: Preto  
 Embalagem: 30 metros

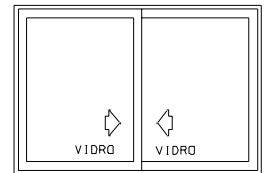
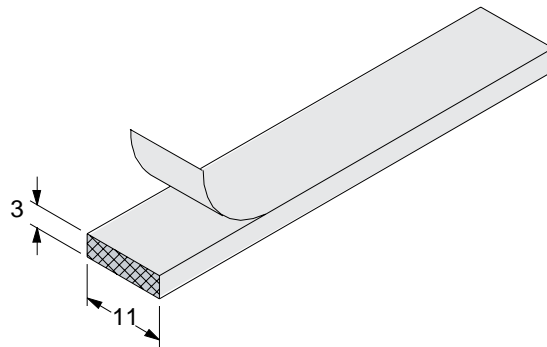

Estoque CD  
 TUB ITS



Ver aplicação na página 106

**GUA-258**

Guarnição adesiva esponjosa  
 Acabamento: Preto  
 Embalagem: 15 metros

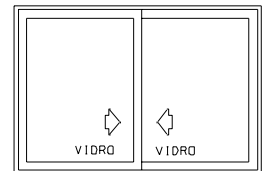
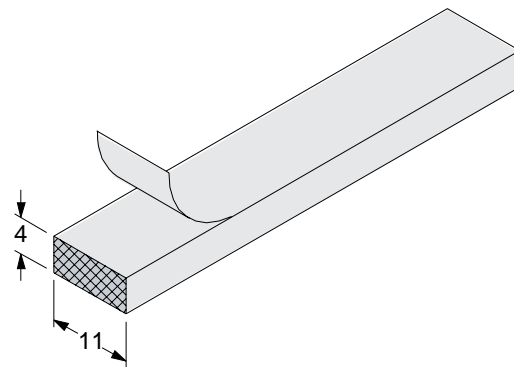

Estoque CD  
 TUB ITS



Ver aplicação na página 106

**GUA-157**

Guarnição adesiva esponjosa  
 Acabamento: Preto  
 Embalagem: 15 metros

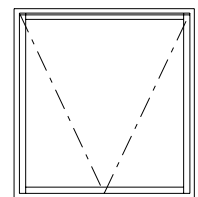
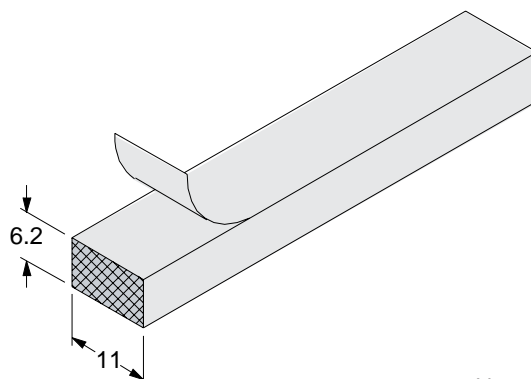

Estoque CD  
 TUB ITS



Ver aplicação na página 106

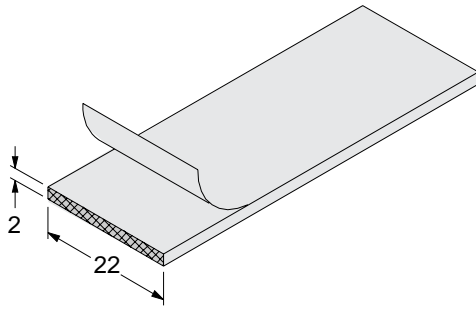

**GUA-282**

Guarnição adesiva esponjosa  
 Acabamento: Preto  
 Embalagem: 61 metros

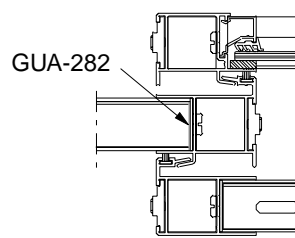

Aplicação

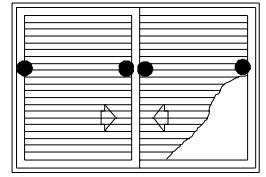

Estoque CD  
 TUB ITS

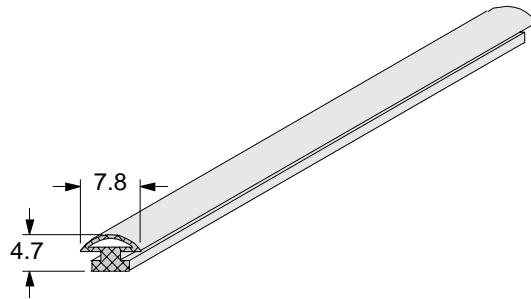

**GUA-053**

Guarnição em EPDM  
 Acabamento: Preto  
 Embalagem: 50 metros

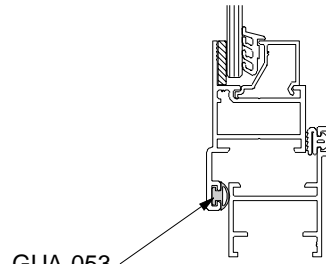

Aplicação

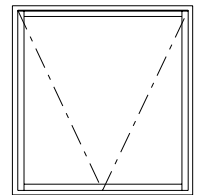

Estoque CD  
 TUB ITS

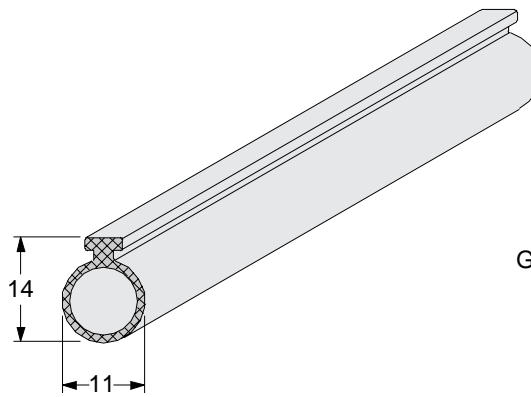

**GUA-007**

Guarnição em EPDM  
 Acabamento: Preto  
 Embalagem: 50 metros

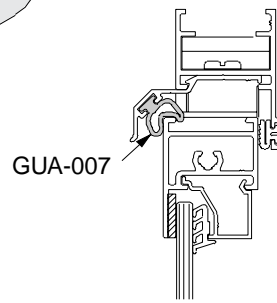

Aplicação

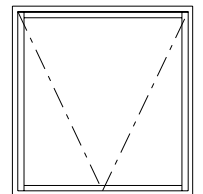

Estoque CD  
 TUB ITS

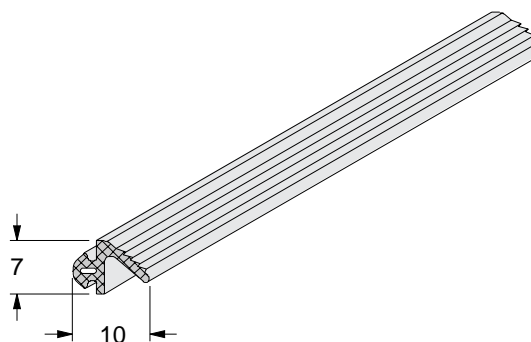

**GUA-239**

Guarnição em EPDM  
 Acabamento: Preto  
 Embalagem: 50 metros

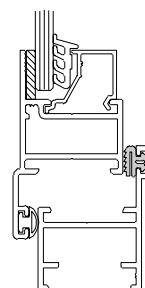

Aplicação

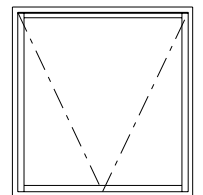

Estoque CD  
 TUB ITS

**GUA-256**

Guarnição em EPDM  
 Acabamento: Preto  
 Embalagem: 50 metros

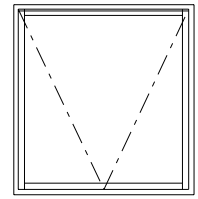
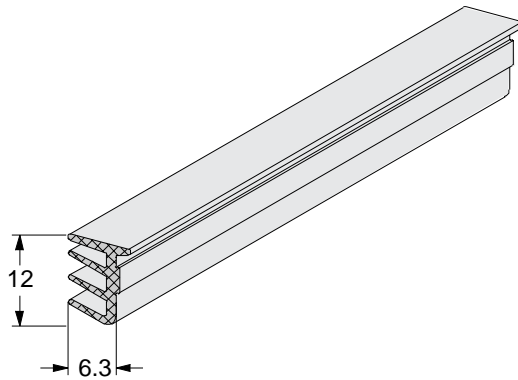

Ver aplicação na página 106

Estoque CD  
 TUB ITS

**GUA-259**

Guarnição em EPDM  
 Acabamento: Preto  
 Embalagem: 50 metros

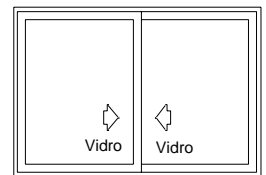
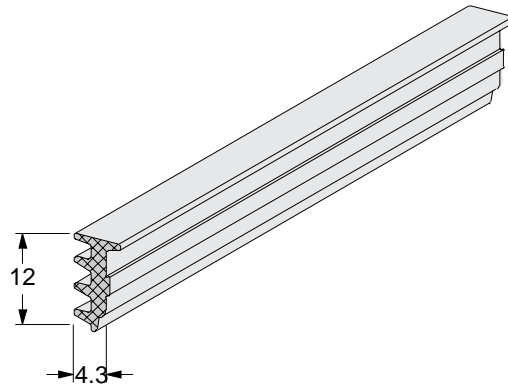

Ver aplicação na página 106

Estoque CD  
 TUB ITS

Para vidro 4 mm

**GUA-284**

Guarnição em EPDM  
 Acabamento: Preto  
 Embalagem: 50 metros

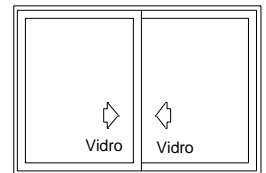
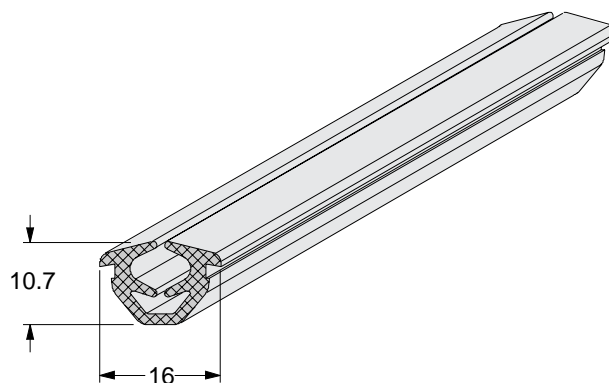

Ver aplicação na página 106

Estoque CD  
 TUB ITS

Para vidros 5 e 6 mm

**GUA-283**

Guarnição em EPDM  
 Acabamento: Preto  
 Embalagem: 50 metros

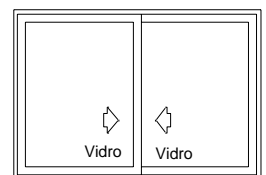
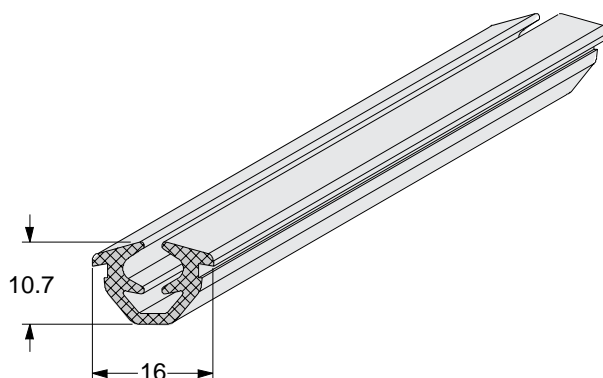

Ver aplicação na página 106

Estoque CD  
 TUB ITS

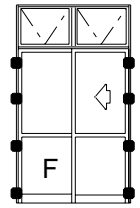
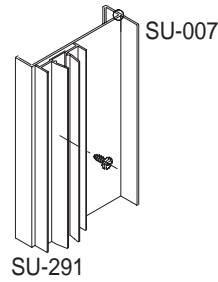
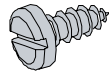

**PAR-437**

Parafuso 3.5 x 9.5 mm cabeça panela  
 Acabamento: Inox  
 Embalagem: 100 peças

Aplicação

Estoque CD  
 TUB ITS

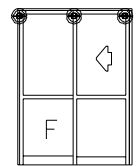
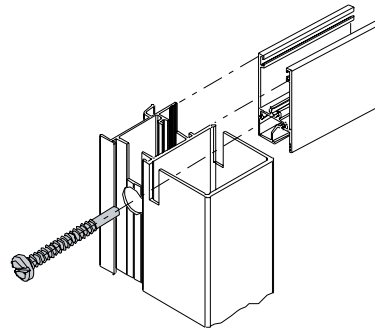
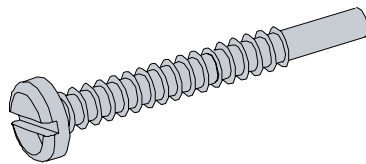

**PAR-428**

Parafuso 4.8 x 32 mm cabeça panela  
 Acabamento: Inox  
 Embalagem: 100 peças

Aplicação

Estoque CD  
 TUB ITS

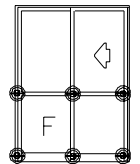
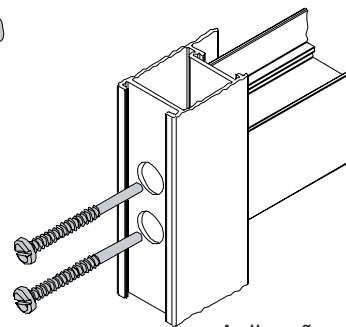
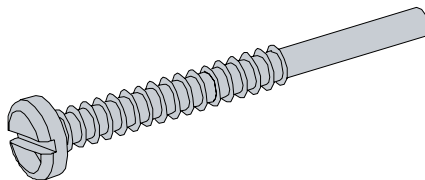

**PAR-431**

Parafuso 4.8 x 50 mm cabeça panela  
 Acabamento: Inox  
 Embalagem: 100 peças

Aplicação

Estoque CD  
 TUB ITS

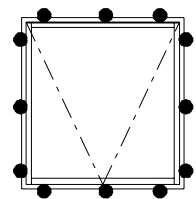
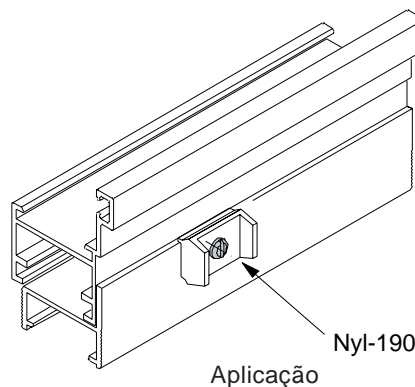
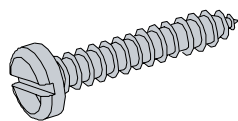

**PAR-936**

Parafuso 4.2 x 16 mm cabeça panela  
 Acabamento: Inox  
 Embalagem: 100 peças

Aplicação

Estoque CD  
 TUB ITS



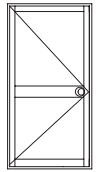
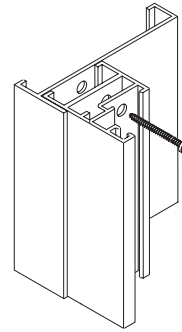
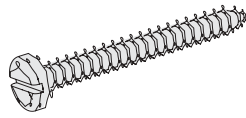

**PAR-694**

Parafuso 4.2 X 32mm cabeça panela  
 Acabamento: Inox  
 Embalagem: 100 peças

SU-279

Aplicação

Estoque CD  
 TUB ITS

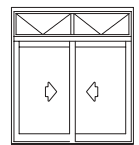
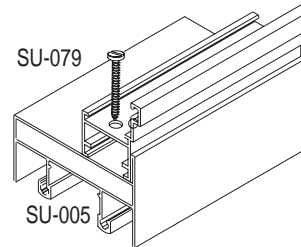
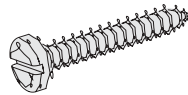

**PAR-693**

Parafuso 4.2 X 25mm cabeça panela  
 Acabamento: Inox  
 Embalagem: 100 peças

Aplicação

Estoque CD  
 TUB ITS

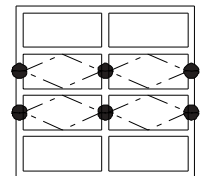
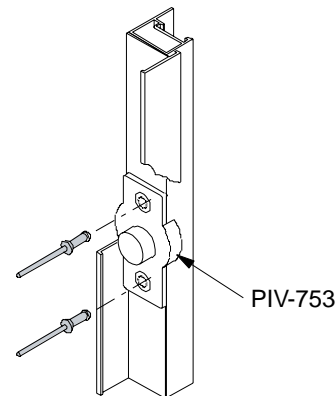
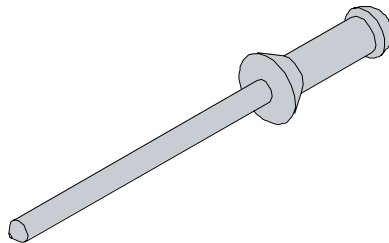

**REB-115**

Rebite de repuxo 4 x 10.2 mm  
 Acabamento: Alumínio preto  
 Embalagem: 1.000 peças

Aplicação

Estoque CD  
 TUB ITS

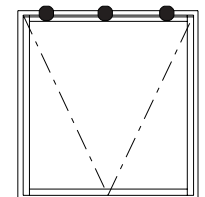
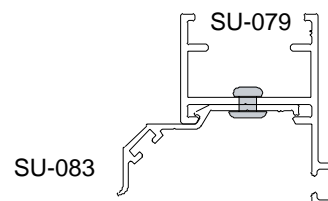
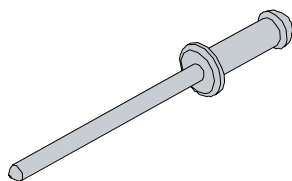

**REB-117**

Rebite de repuxo 3.2 x 10.2 mm  
 Acabamento: Alumínio  
 Embalagem: 1.000 peças

Aplicação

Estoque CD  
 TUB ITS

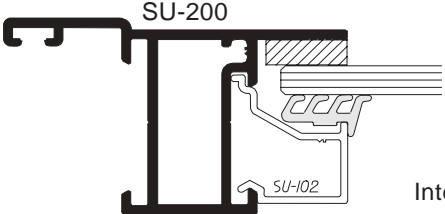
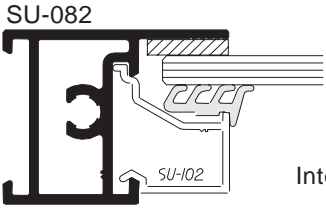
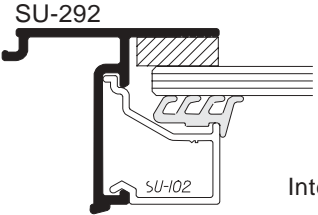
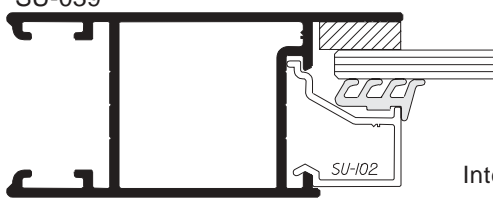
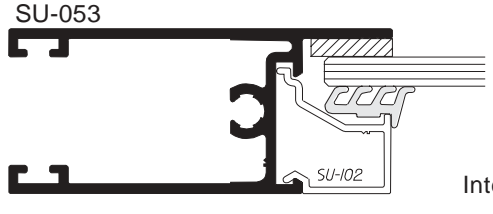
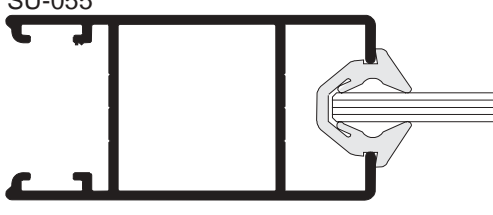

Detalhes		Espessura vidro	Guarnição interna	Guarnição externa
 <p>SU-200</p> <p>SU-102</p>	Externo	3	GUA-256	GUA-157
	Interno	4	GUA-256	GUA-157
		5	GUA-256	GUA-258
	6	GUA-259	GUA-157	
 <p>SU-082</p> <p>SU-102</p>	Externo	3	GUA-256	GUA-258
	Interno	4	GUA-256	GUA-258
		5	GUA-256	GUA-171
	6	GUA-259	GUA-157	
 <p>SU-292</p> <p>SU-102</p>	Externo	3	GUA-256	GUA-258
	Interno	4	GUA-256	GUA-258
		5	GUA-256	GUA-171
	6	GUA-259	GUA-171	
 <p>SU-039</p> <p>SU-102</p>	Externo	4	GUA-256	GUA-157
	Interno	5	GUA-256	GUA-258
		6	GUA-259	GUA-258
 <p>SU-053</p> <p>SU-102</p>	Externo	4	GUA-256	GUA-258
	Interno	5	GUA-256	GUA-171
		6	GUA-259	GUA-171
 <p>SU-055</p>		4	GUA-284	
		5	GUA-283	
		6	GUA-283	

Detalhe de travamento do trilho da porta de correr para evitar a deflexão do trilho.

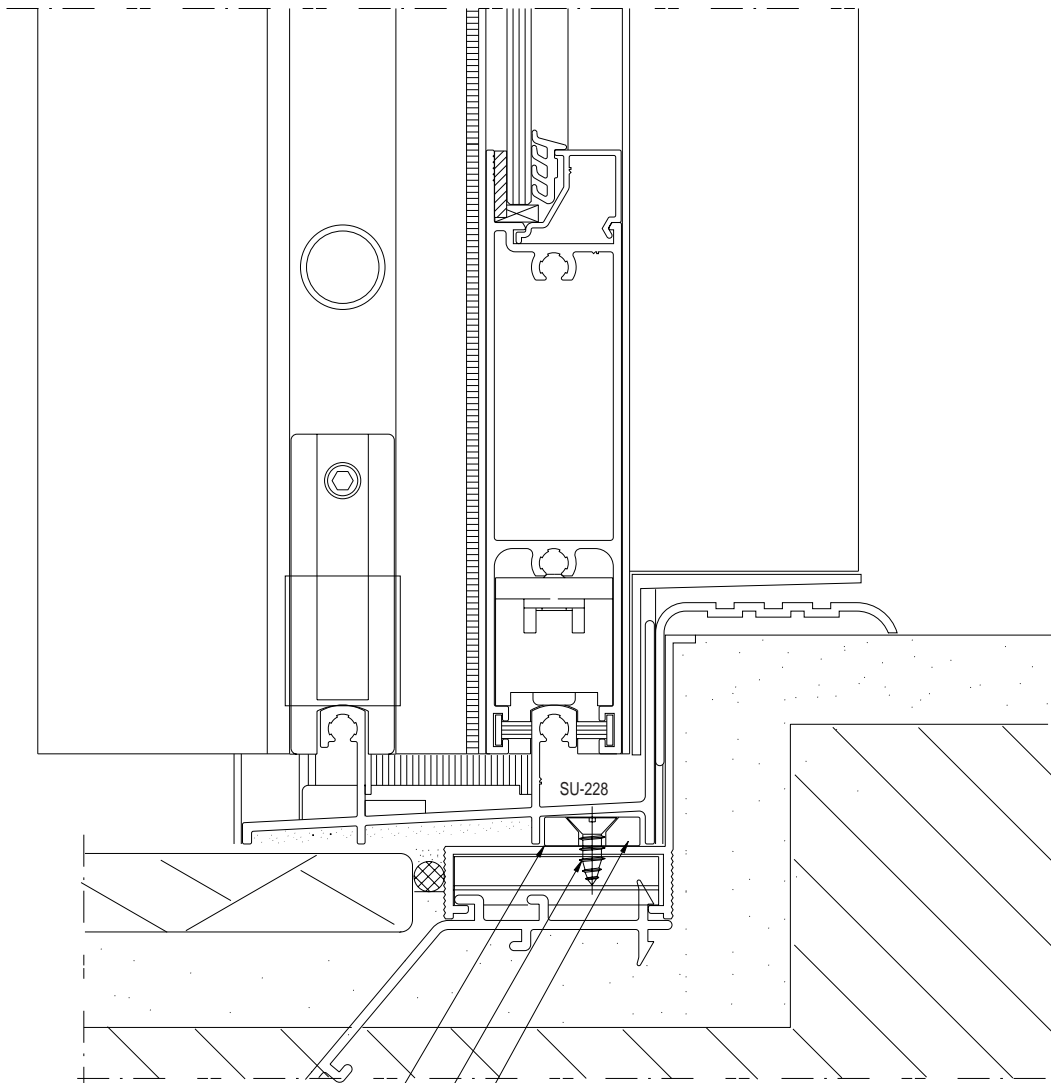

- Calços em barra chata perfil BC-009 (4.76x15.8x40mm)
- Parafuso cx. 4.8x13mm aço inox
- Fixar os calços aplicando silicone na parte inferior

## Trilho Suprema SU-228

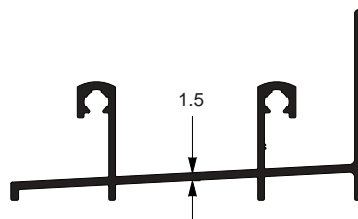

- Módulo 2000 x 2000mm
- Pressão de ensaio = 150 kg/m<sup>2</sup>
- Pressão de sucção = 120 kg/m<sup>2</sup>
- Parafuso diâmetro = 4.8mm aço inox

Exemplo de fixação do trilho

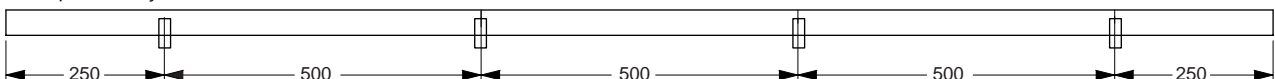



## Capítulo 7

**Estampos/  
Usinagens**

**COMPONENTES**

- 1- FERRAMENTA
- 2- MESA
- 3- PEDAL ACIONAMENTO
- 4- MANÔMETRO
- 5- BICO PARA LIMPEZA

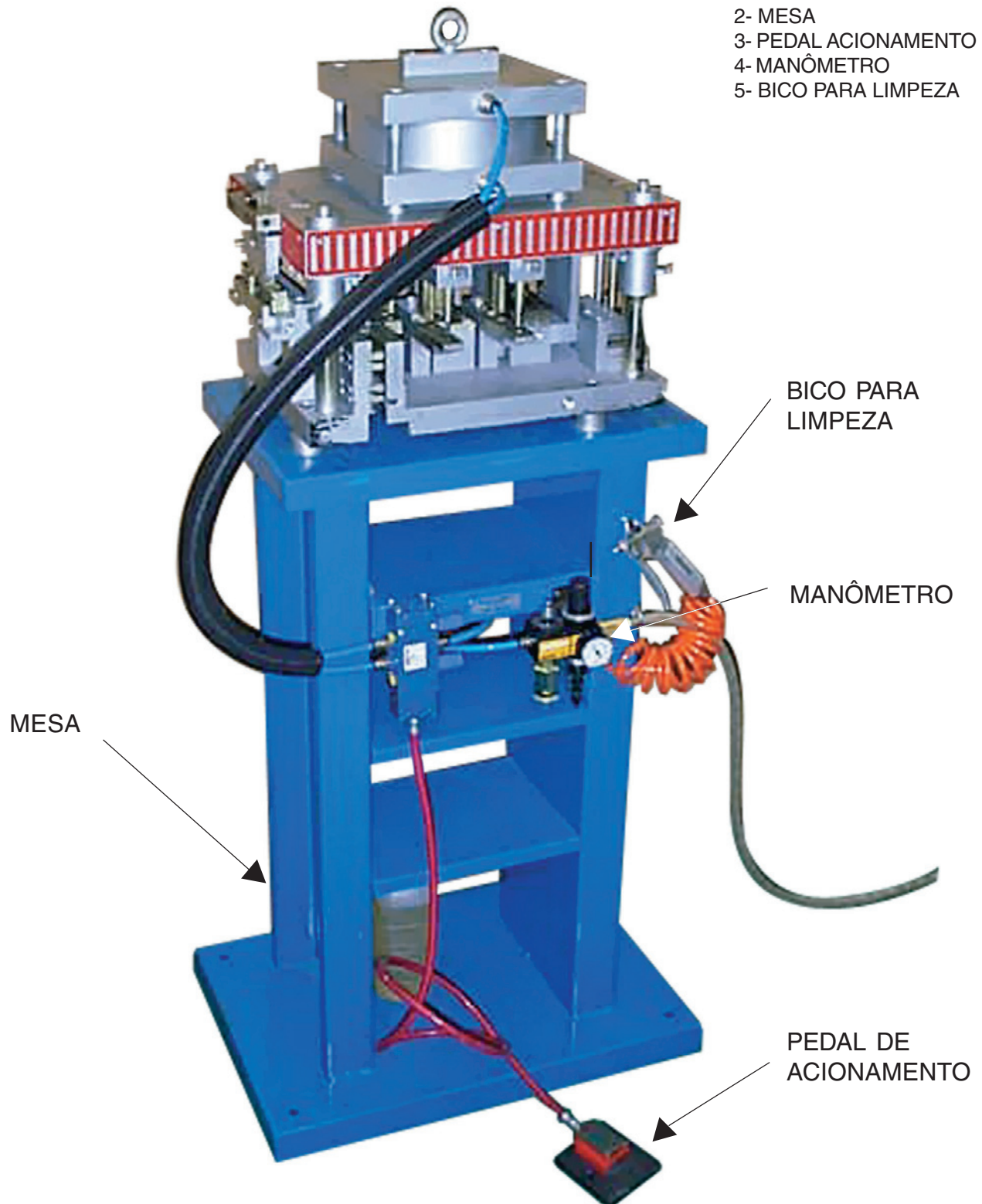

**Prensa pneumática EST-569**

**SU-006**

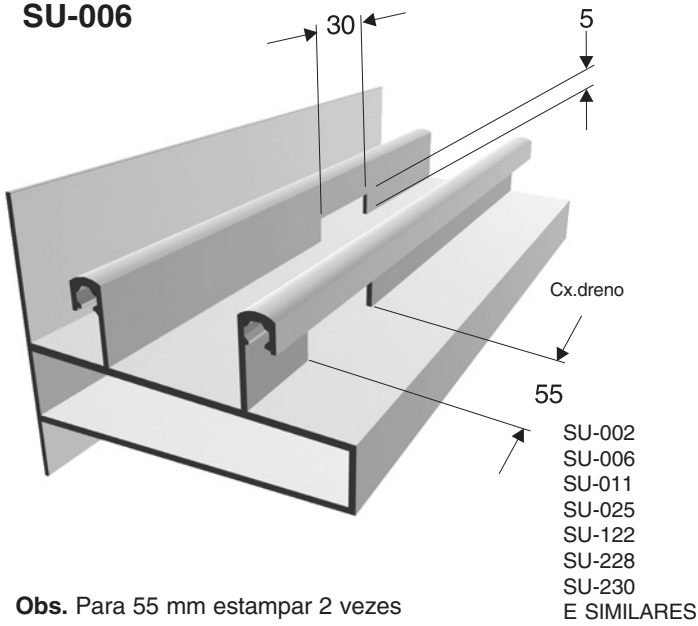

**Obs.** Para 55 mm estampar 2 vezes

**SU-012**

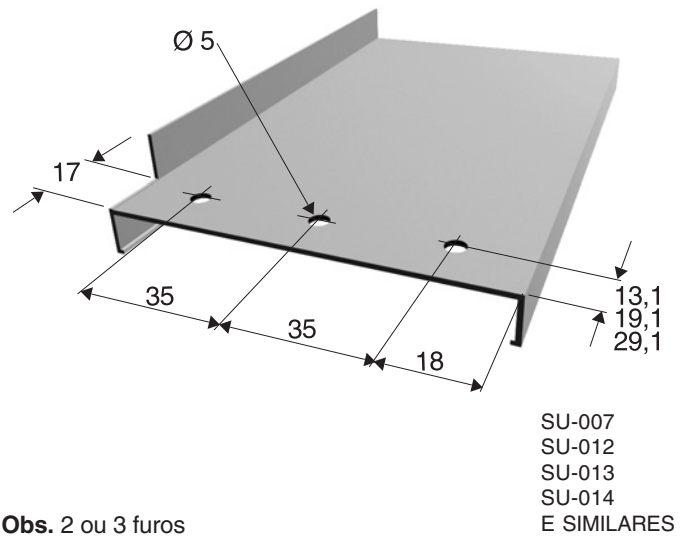

**Obs.** 2 ou 3 furos

**SU-014**

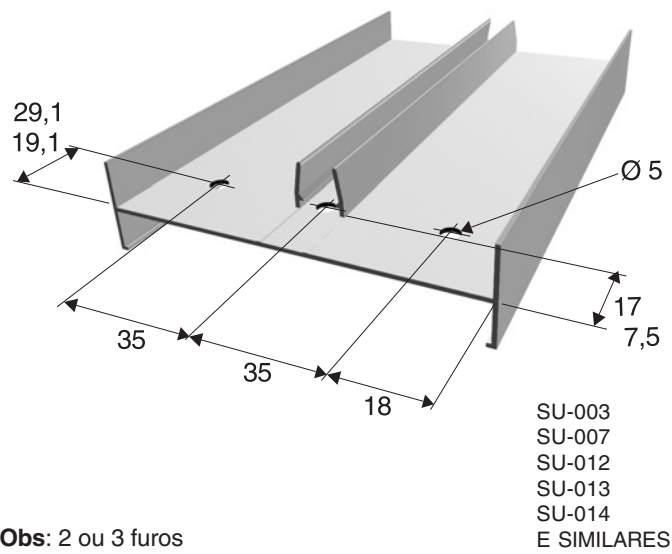

**Obs:** 2 ou 3 furos

**SU-014**

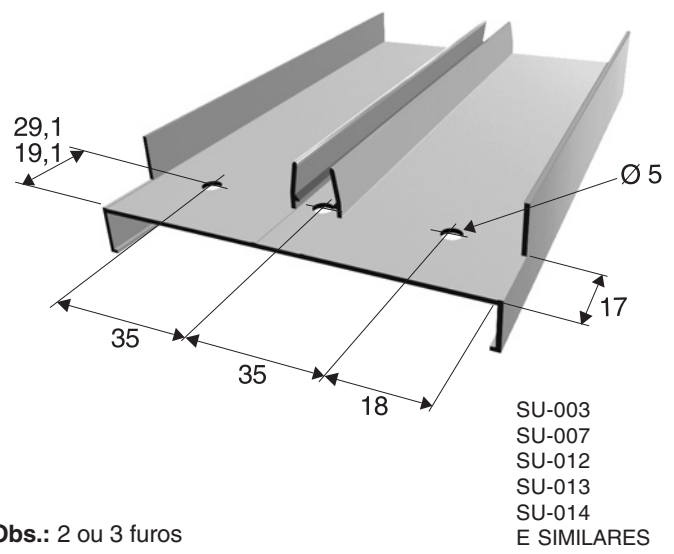

**Obs.:** 2 ou 3 furos

**SU-013**

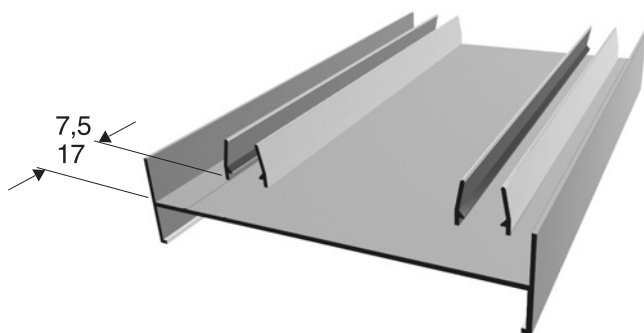

**SU-291**

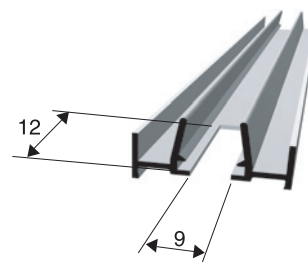

**SU-039**

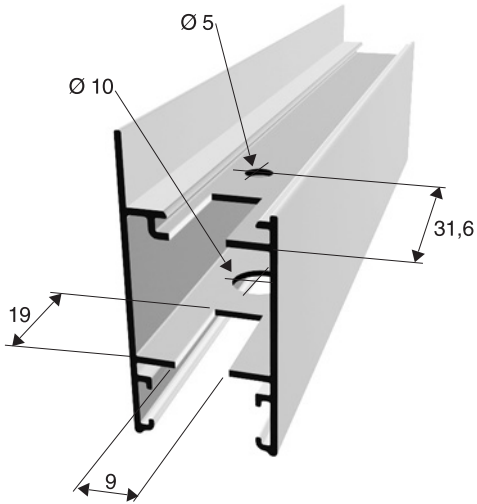

SU-039  
 SU-040  
 SU-041  
 SU-042  
 SU-044  
 SU-047  
 SU-049  
 SU-055  
 SU-056  
 SU-057  
 SU-058  
 SU-060  
 SU-061  
 E SIMILARES

**SU-039**

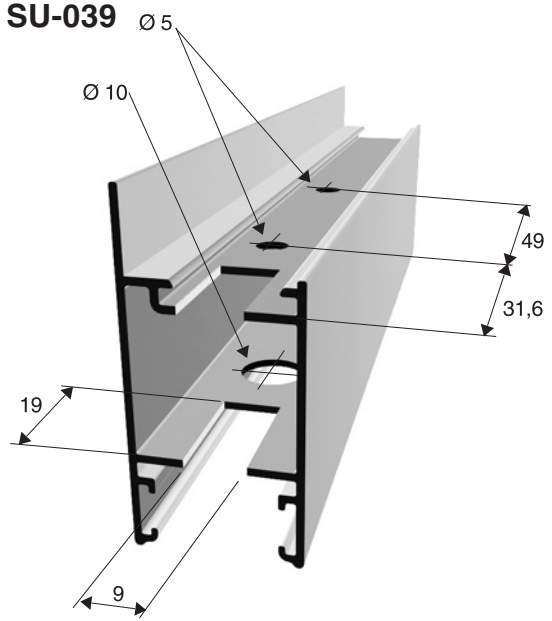

SU-039  
 SU-040  
 SU-041  
 SU-042  
 SU-044  
 SU-047  
 SU-049  
 SU-055  
 SU-056  
 SU-057  
 SU-058  
 SU-060  
 SU-061  
 E SIMILARES

**SU-055**

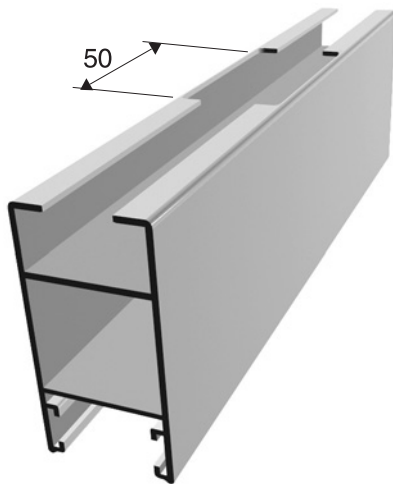

SU-055  
 SU-056  
 SU-057  
 SU-060  
 SU-061  
 SU-239  
 E SIMILARES

**SU-055**

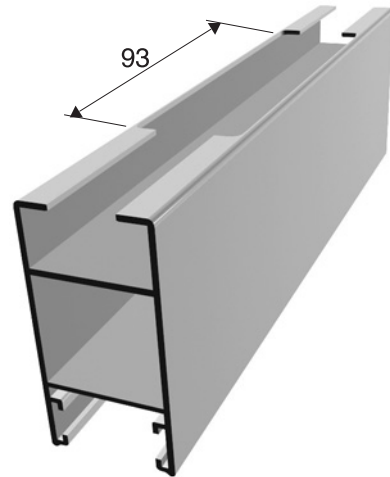

**Obs.:** Para 93 mm estampar 2 vezes

SU-055  
 SU-056  
 SU-057  
 SU-060  
 SU-061  
 SU-239  
 SIMILARES

**SU-055**

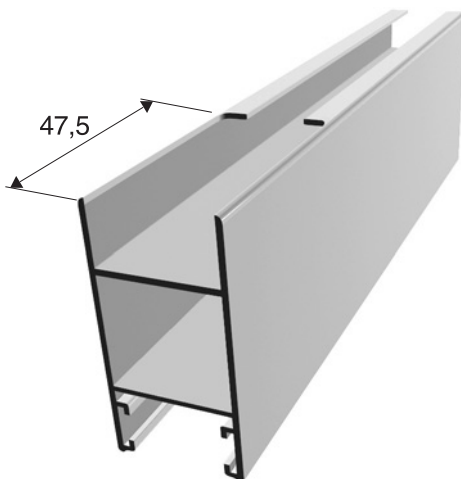

SU-056  
 SU-057  
 SU-060  
 SU-061  
 E SIMILARES

**SU-055**

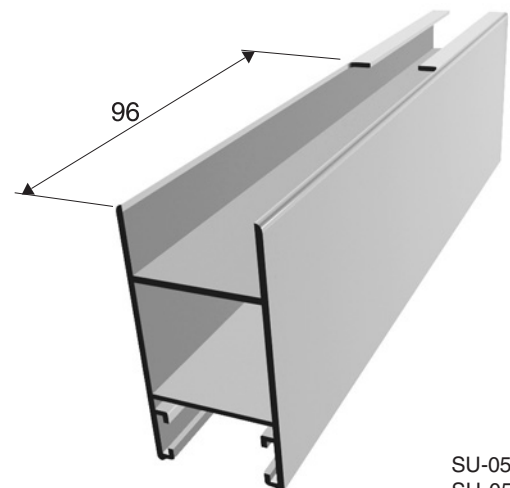

**Obs.:** Para 96 mm estampar 2 vezes

SU-056  
 SU-057  
 SU-060  
 SU-061  
 E SIMILARES

**SU-085**

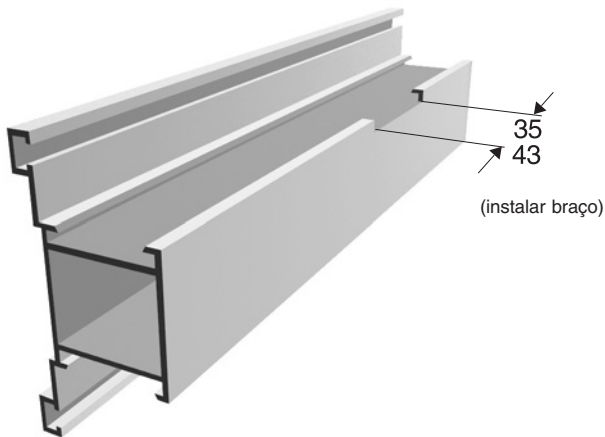

Obs. Para 43mm (estampar 2 vezes)

SU-079  
SU-085  
SU-086

**SU-085**

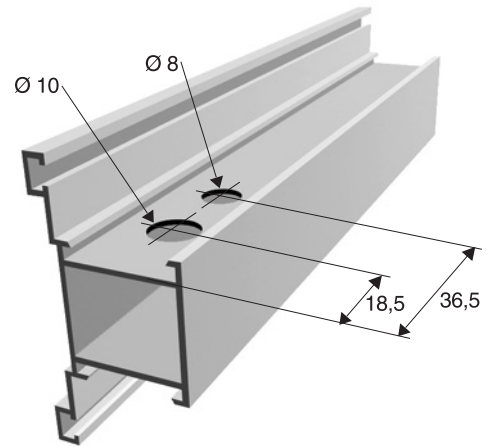

**SU-276**

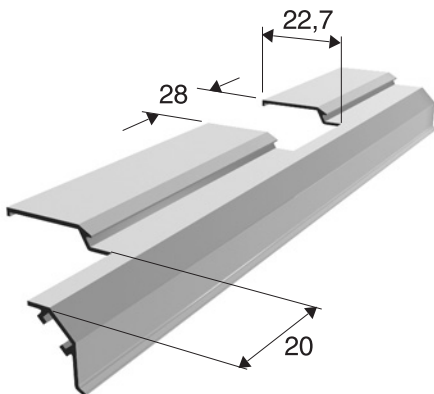

**SU-084**

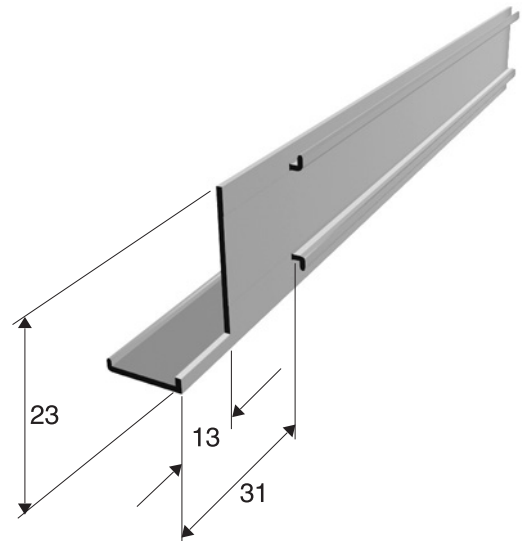

**SU-081**

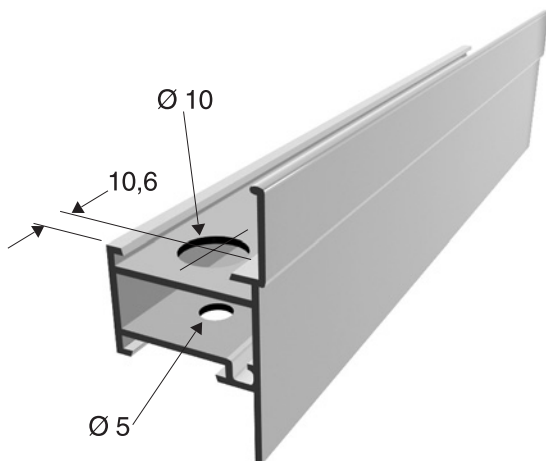

SU-081  
E SIMILARES

**SU-081**

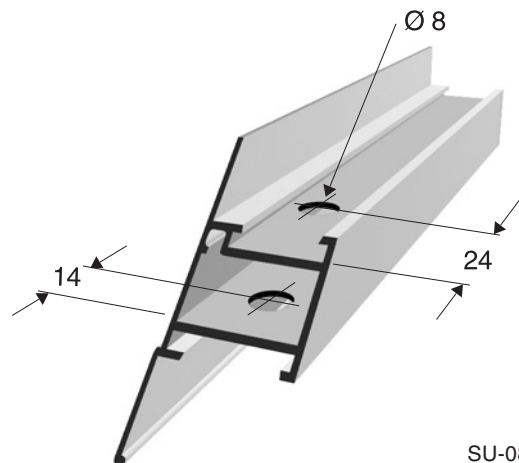

SU-080  
SU-081  
SU-200  
E SIMILARES



**SU-081**

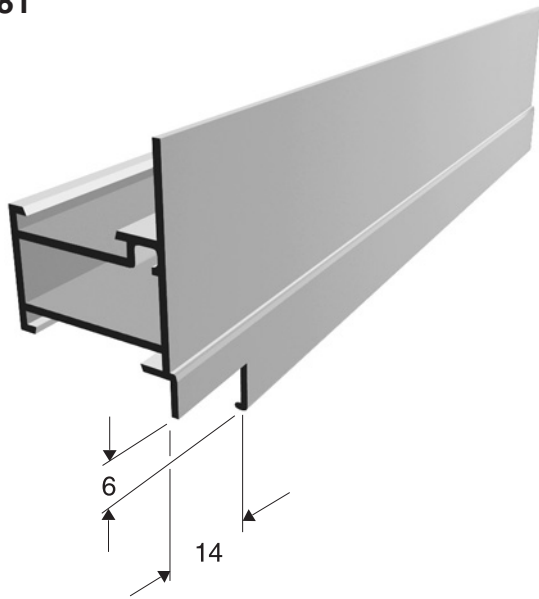

**SU-081**

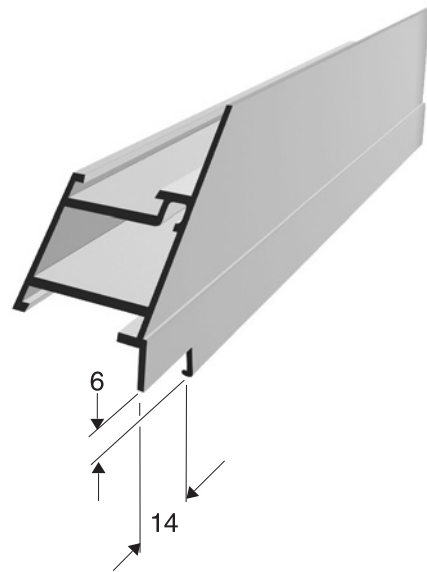

**SU-080**

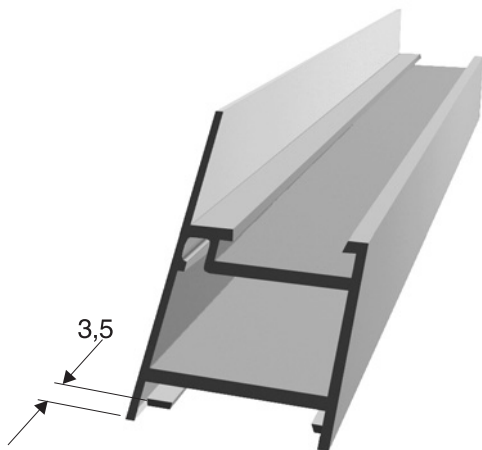

**Obs.:** Somente na travessa superior 45°



## Capítulo 8

# Montagens

Montagem	Descrição	Página
SUP JCR 200	Janela de correr 2 folhas	117
SUP JCR 200A	Janela de correr 2 folhas	118
SUP JCR 300	Janela de correr 3 folhas	119
SUP JCR 400	Janela de correr 4 folhas	120
SUP JCR 400A	Janela de correr 4 folhas	121
SUP JCR 205	Janela de correr 2 folhas com bandeira móvel	122
SUP JCR 402	Janela de correr 4 folhas com peitoril fixo	123
SUP JCR 402A	Janela de correr 4 folhas com peitoril fixo	124
SUP JVZ 300	Janela de correr 3 folhas com veneziana	125
SUP JCR 204	Janela de correr 4 folhas com veneziana	126
SUP JVC 701	Janela de correr 2 folhas com veneziana camarão	127
SUP JVZ 600	Janela de correr 6 folhas com veneziana	128
SUP PVZ 300	Porta de correr 3 folhas com veneziana	129
SUP PCR 200	Porta de correr 2 folhas	130
SUP PCR 200A	Porta de correr 2 folhas	131
SUP PCR 400	Porta de correr 4 folhas	132
SUP PCR 400A	Porta de correr 4 folhas	133
SUP PCR 300	Porta de correr 3 folhas	134
SUP PGR 100	Porta de giro 1 folha	135
SUP PGR 200	Porta de giro 2 folhas	136
SUP MAX 800	Janela maximar 1 folha	137
SUP MAX 801	Janela maximar 2 folhas com peitoril fixo	138

ELEVAÇÃO VISTA EXTERNA

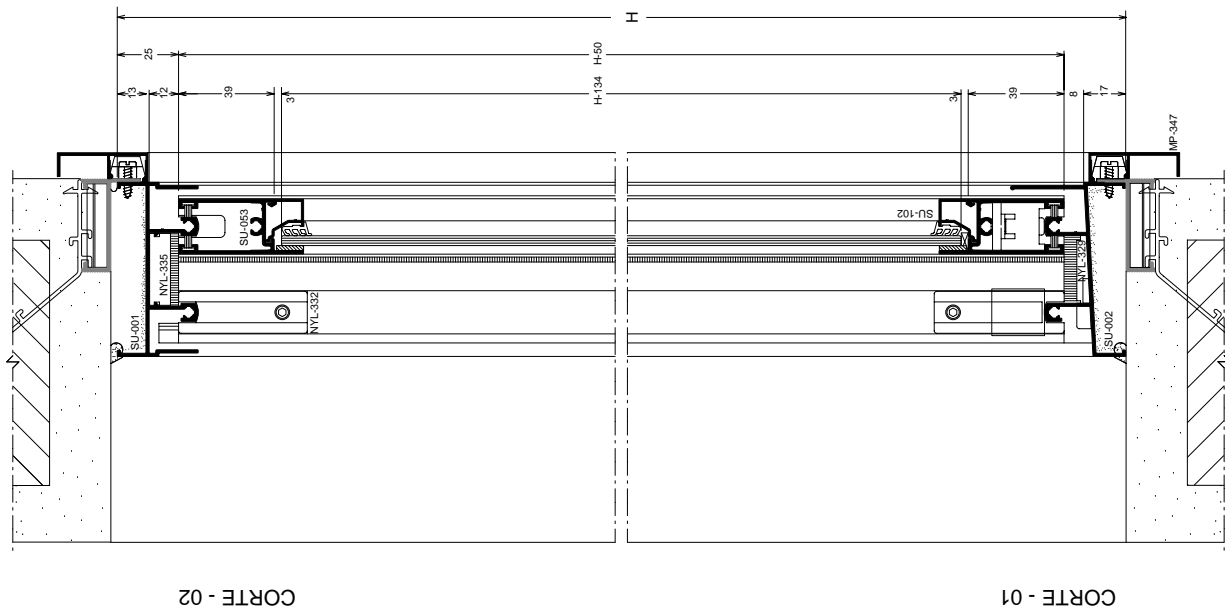
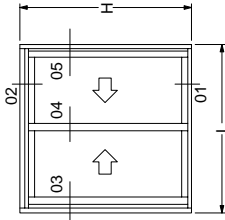

LADO EXTERNO

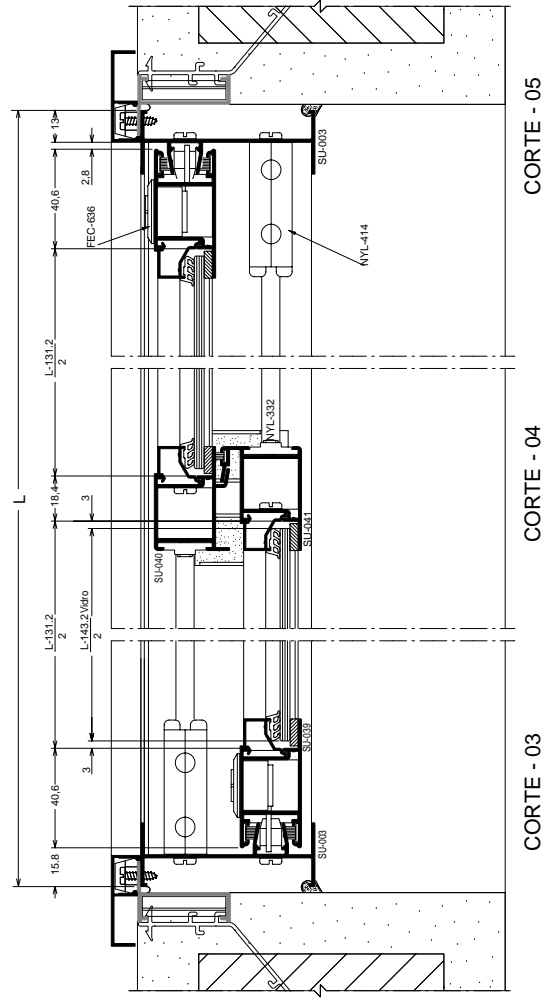

CORTE - 05

CORTE - 04

CORTE - 03

LADO EXTERNO

SUP JCR 200



ELEVAÇÃO VISTA EXTERNA

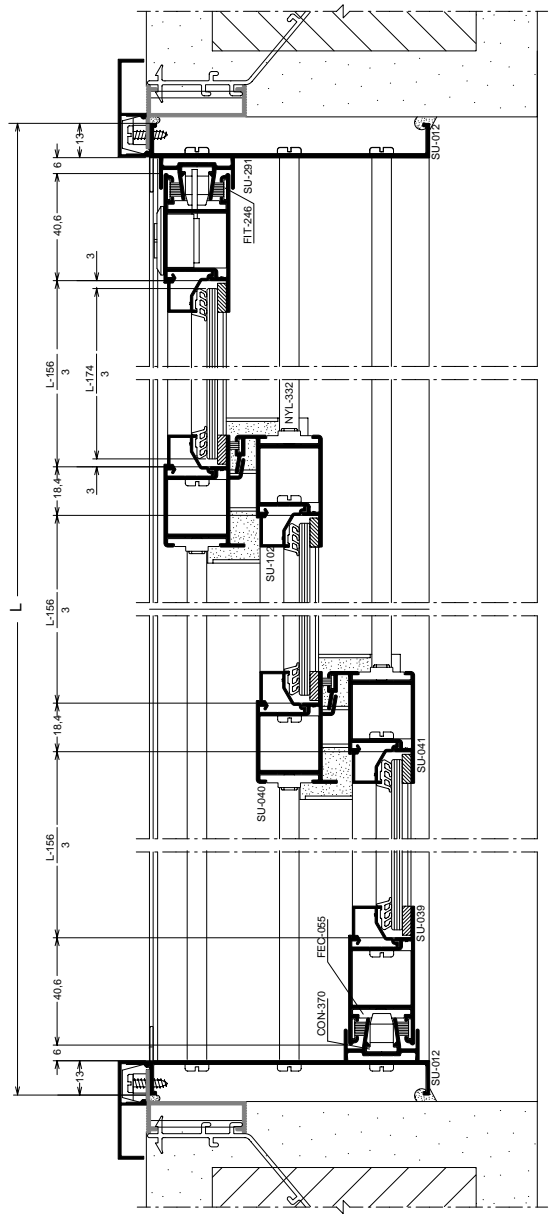
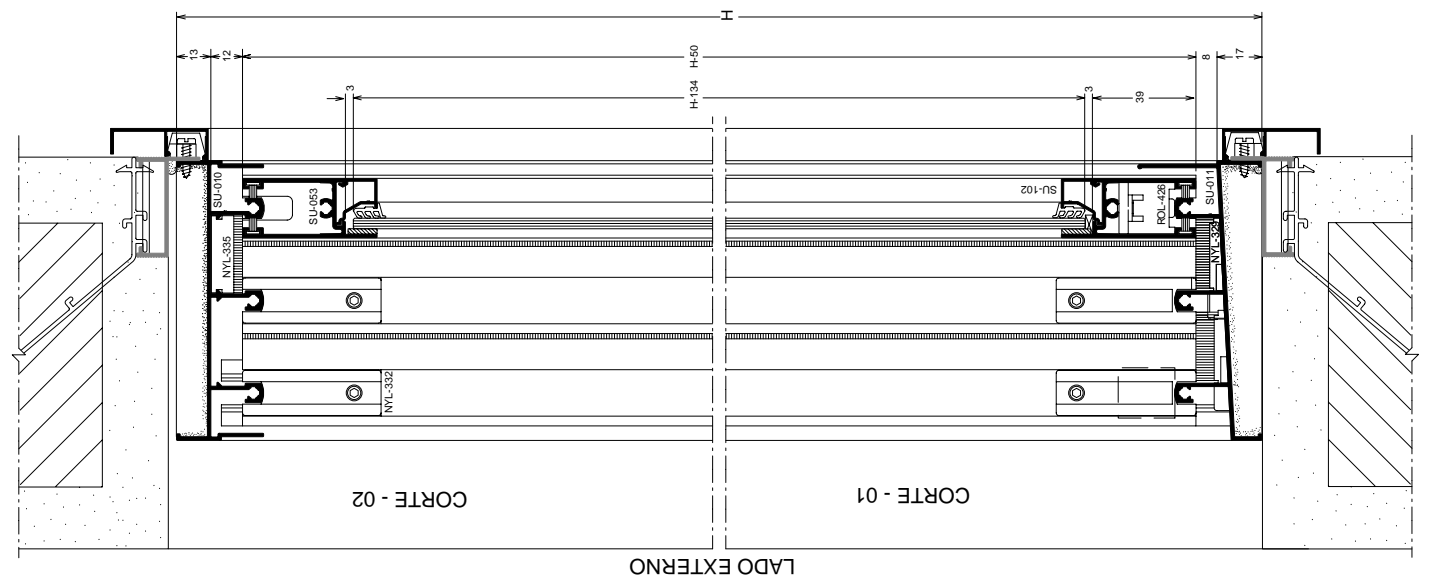
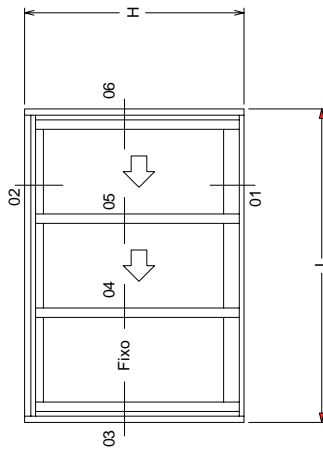

LADO EXTERNO

SUP JCR 300

ELEVAÇÃO VISTA EXTERNA

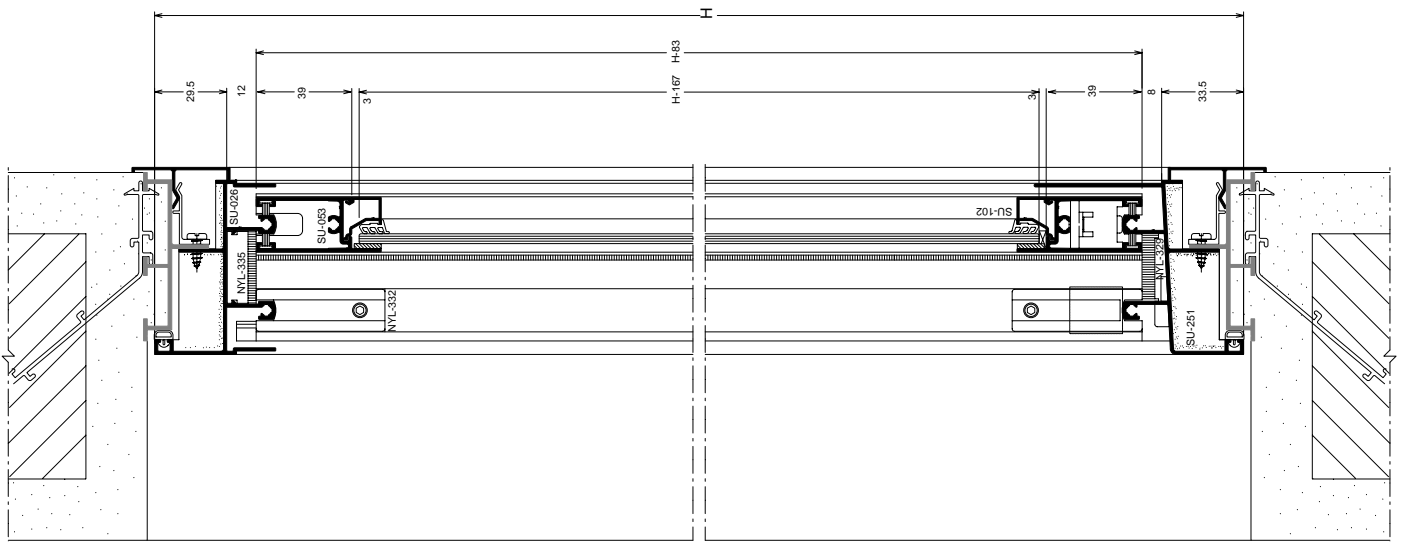
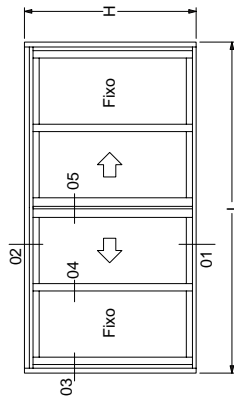

CORTE - 02

LADO EXTERNO

CORTE - 01

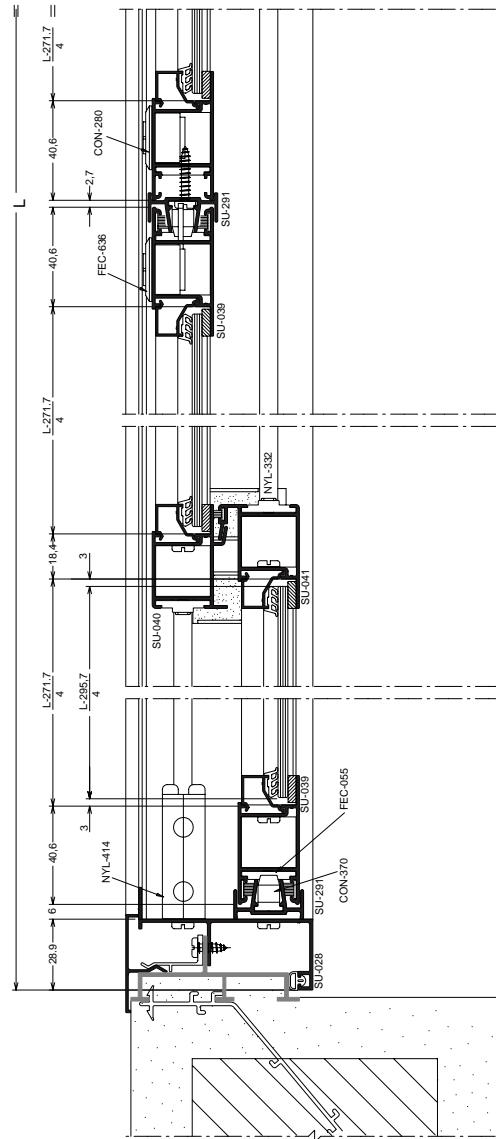

CORTE - 03

CORTE - 04

CORTE - 05

LADO EXTERNO

ELEVAÇÃO VISTA EXTERNA

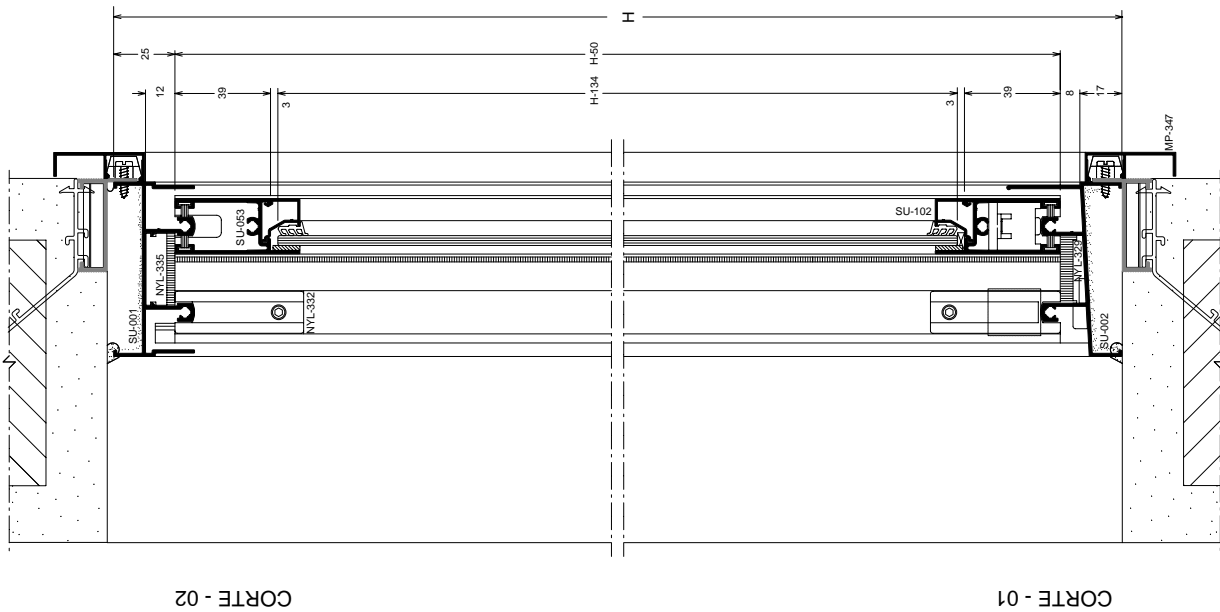
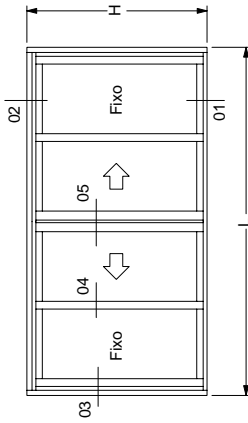

LADO EXTERNO

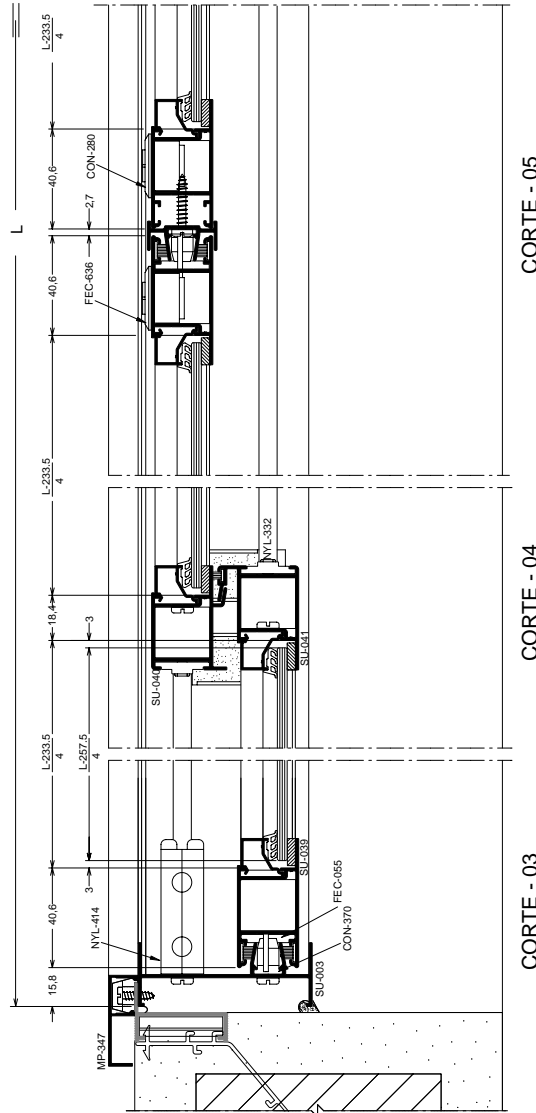

CORTE - 05

CORTE - 04

CORTE - 03

LADO EXTERNO







ELEVAÇÃO VISTA EXTERNA

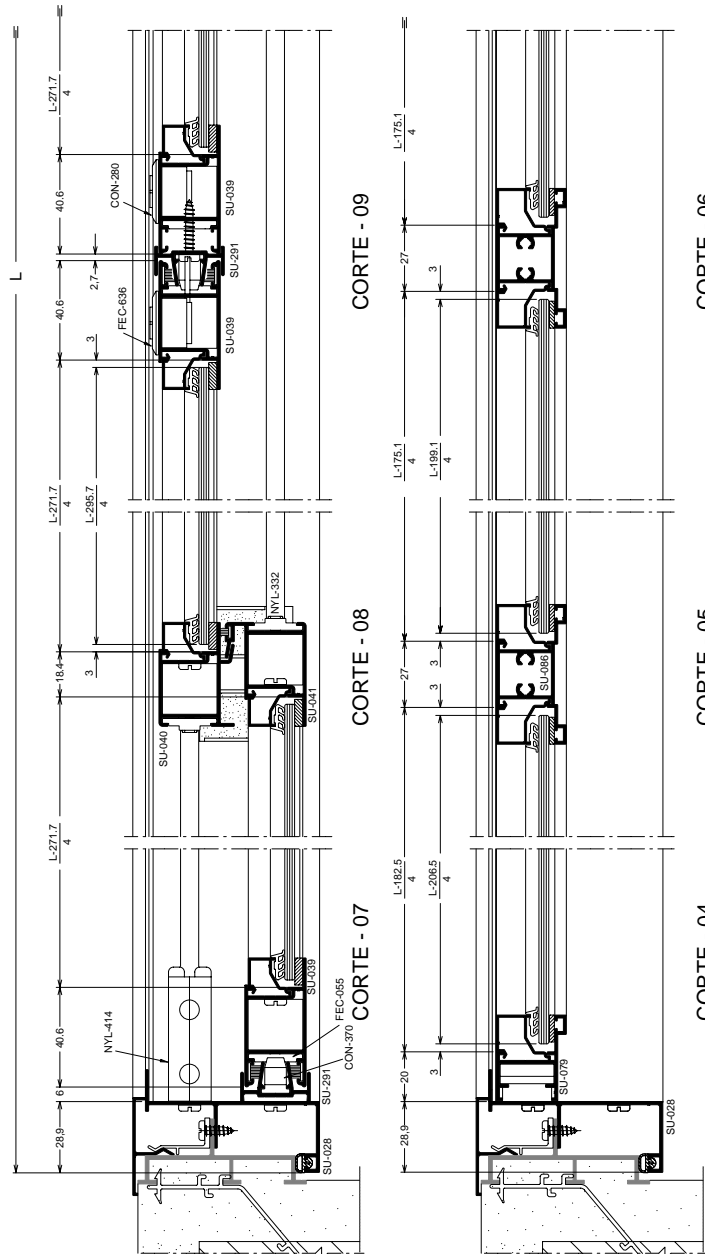
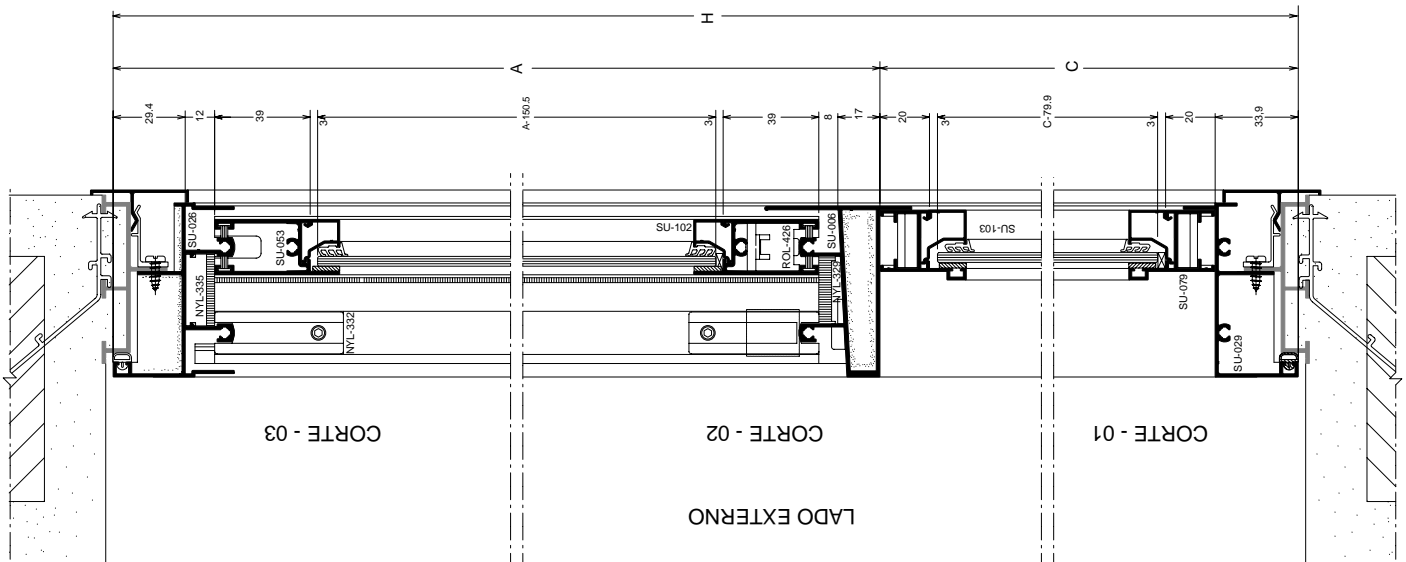
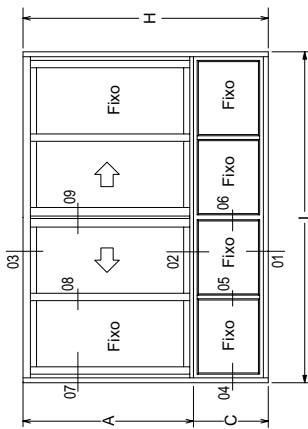

LADO EXTERNO

SUP JCR 402A



ELEVAÇÃO VISTA EXTERNA

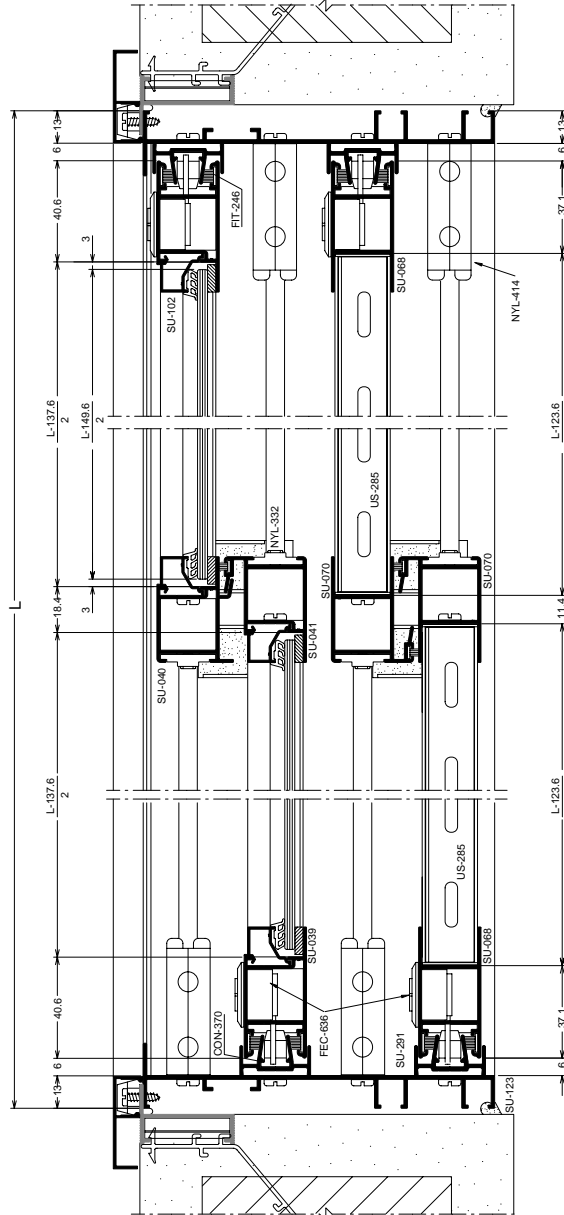
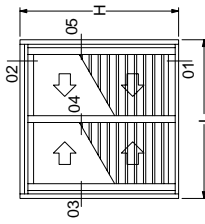

CORTE - 05

CORTE - 04

LADO EXTERNO

CORTE - 03

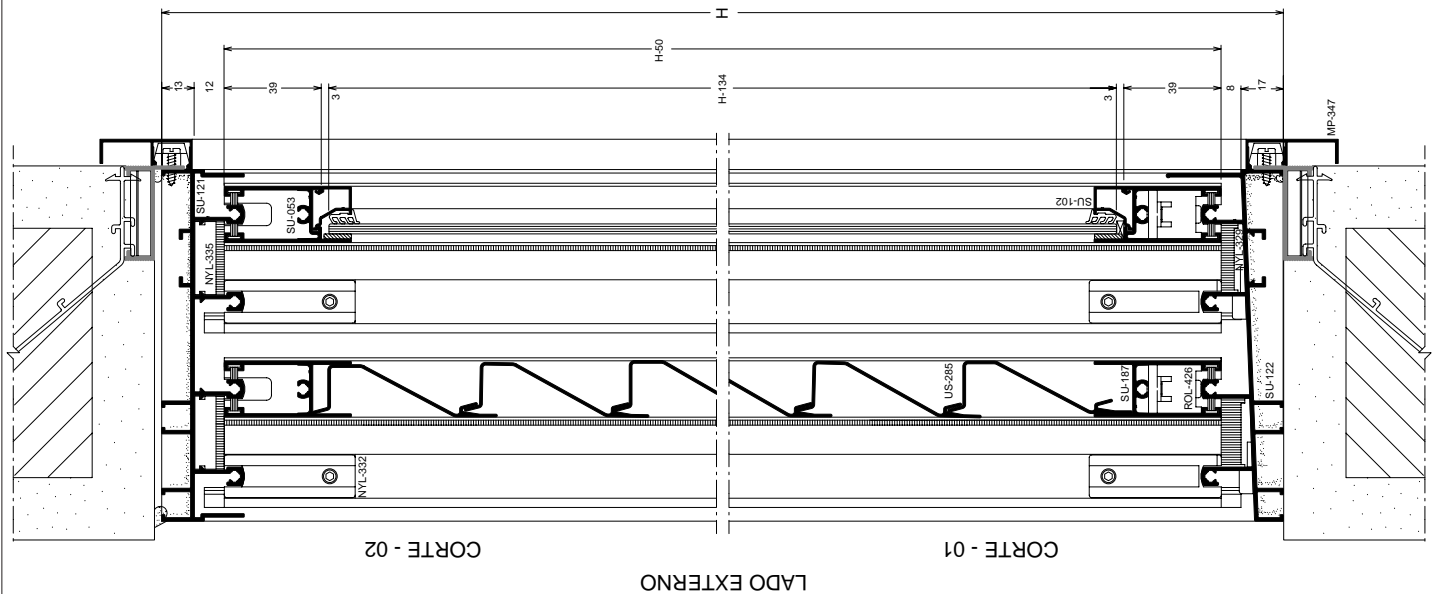

CORTE - 02

LADO EXTERNO

CORTE - 01



ELEVAÇÃO VISTA EXTERNA

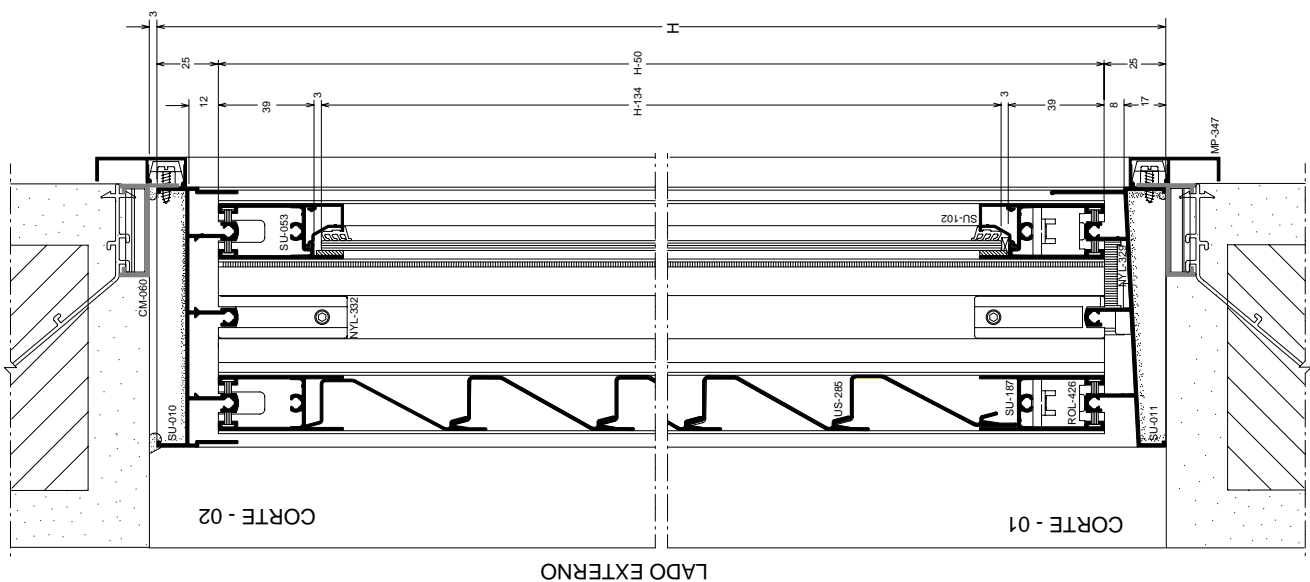
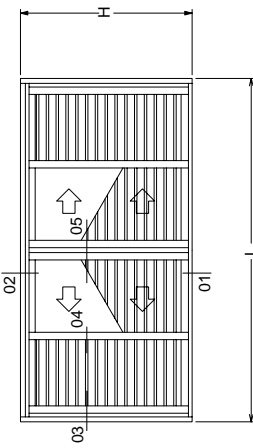

LADO EXTERNO

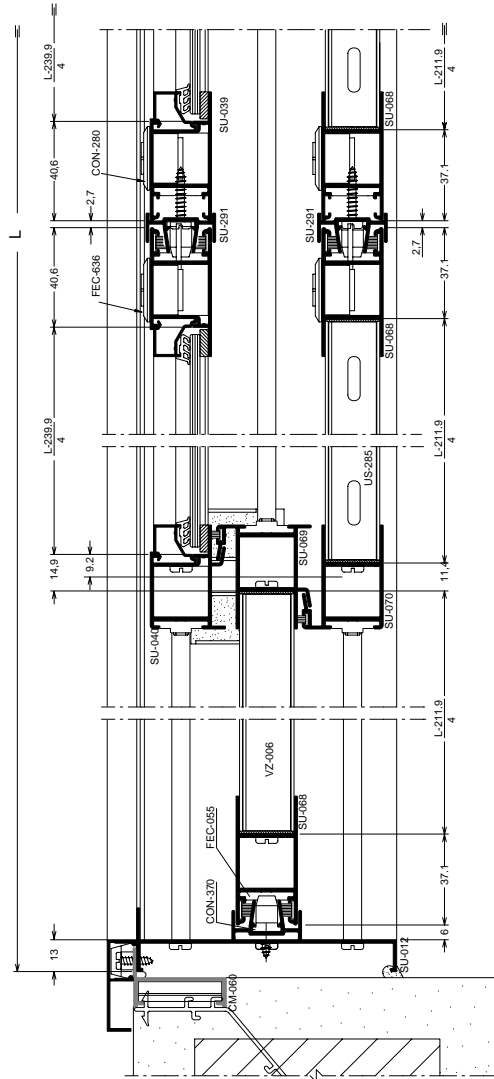

CORTE - 05

CORTE - 04

CORTE - 03

LADO EXTERNO

ELEVAÇÃO VISTA EXTERNA

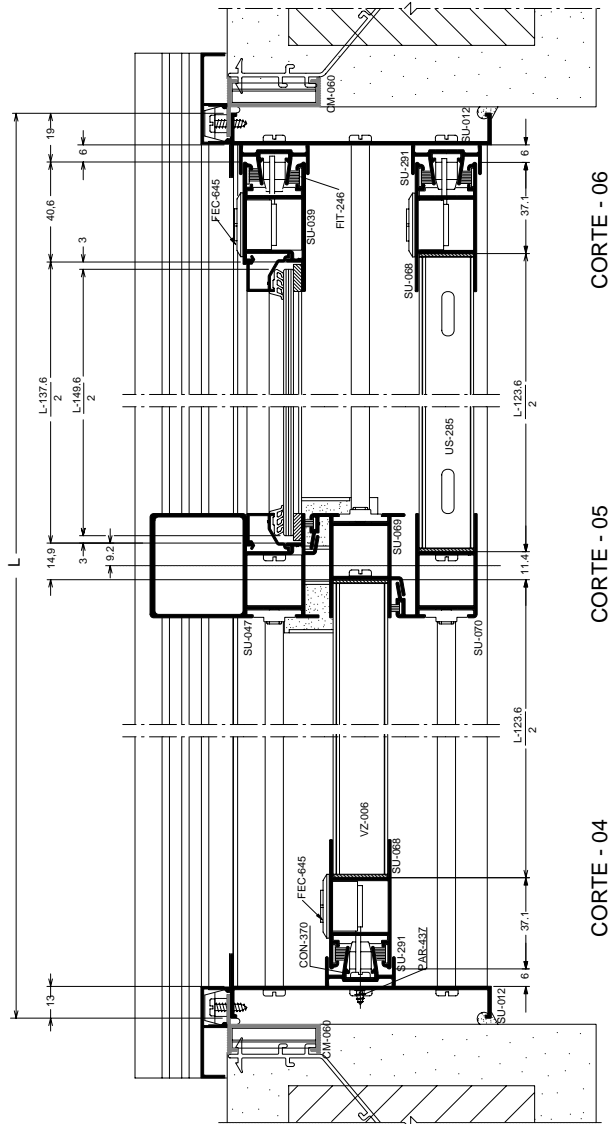
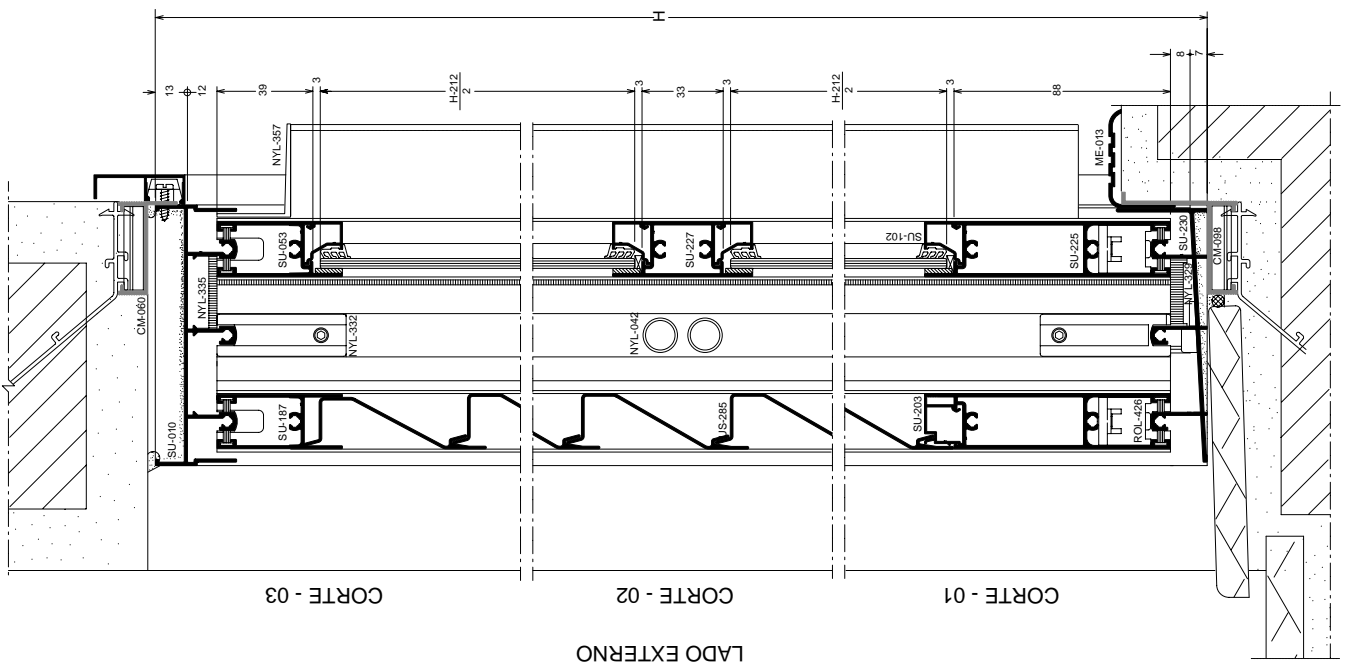
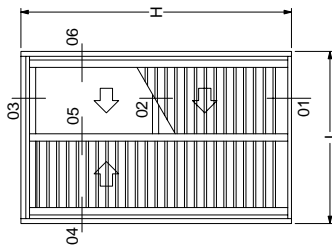

SUP PVZ 300



ELEVAÇÃO VISTA EXTERNA

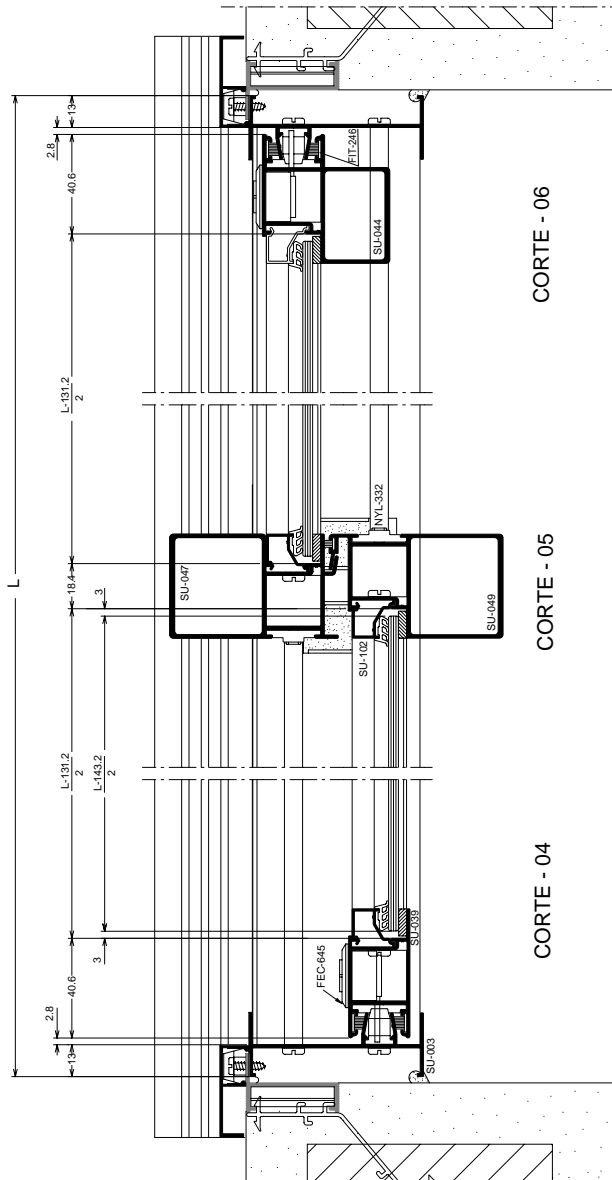
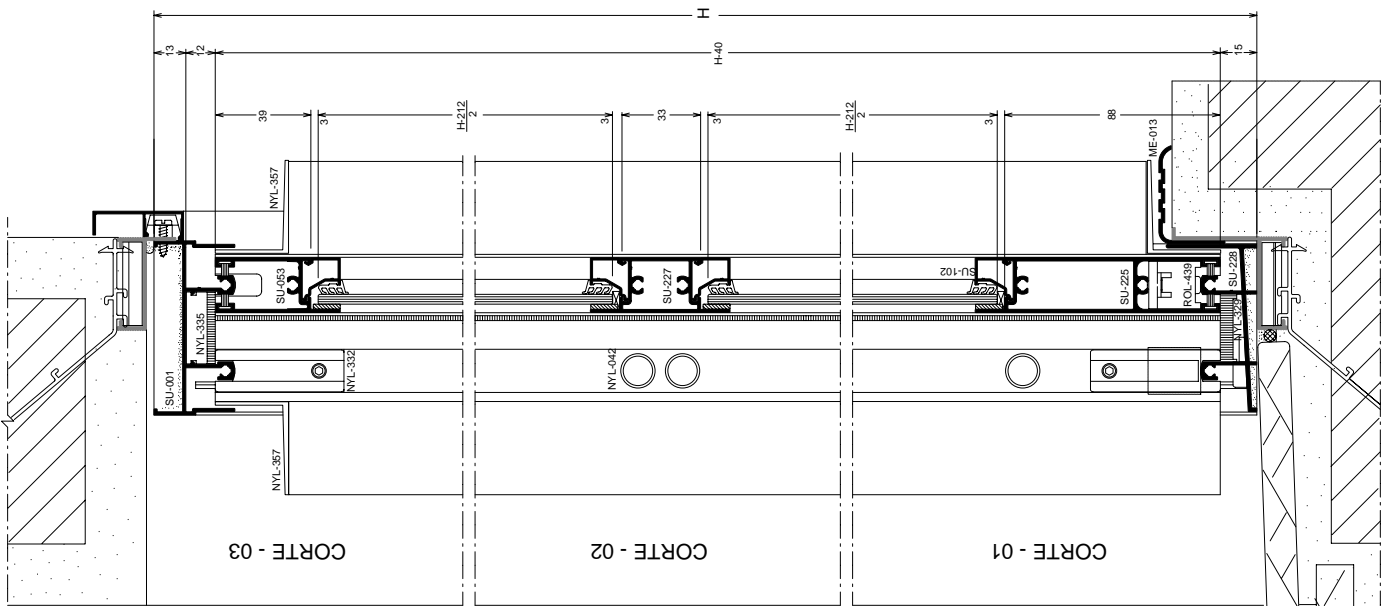
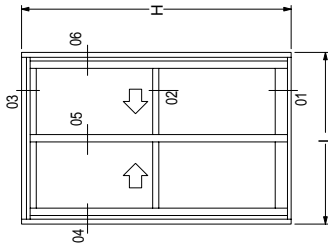

LADO EXTERNO

SUP PCR 200

ELEVAÇÃO VISTA EXTERNA

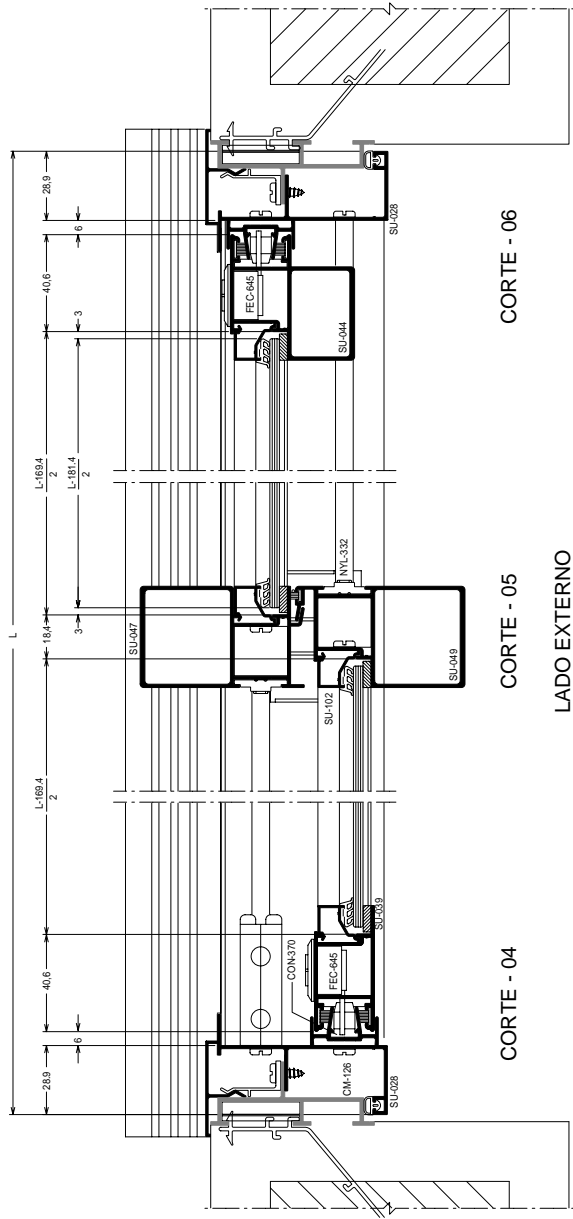
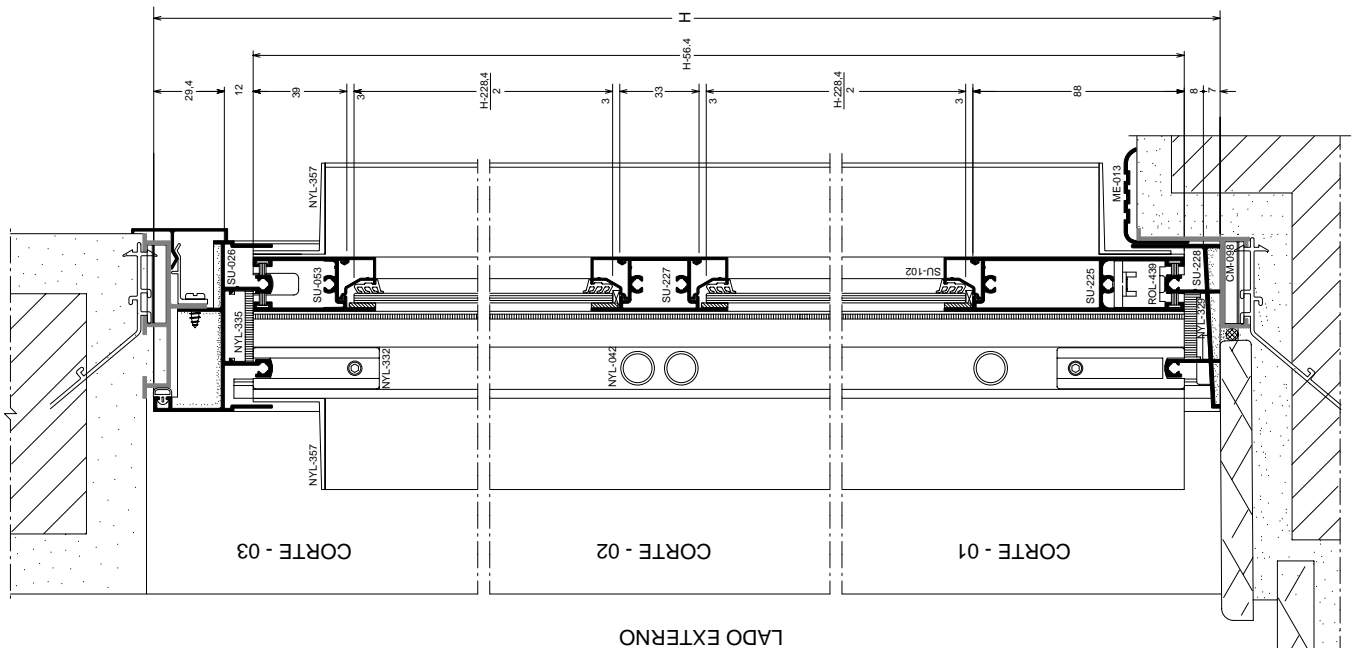
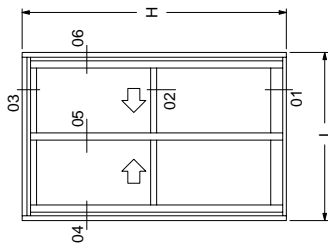

SUP PCR 200A



ELEVAÇÃO VISTA EXTERNA

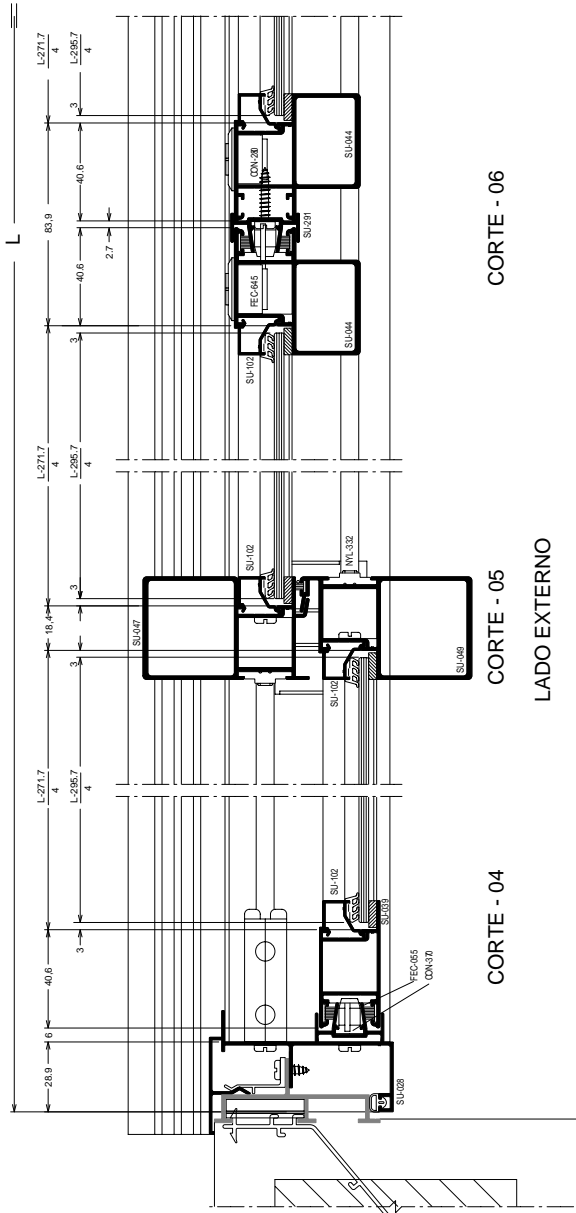
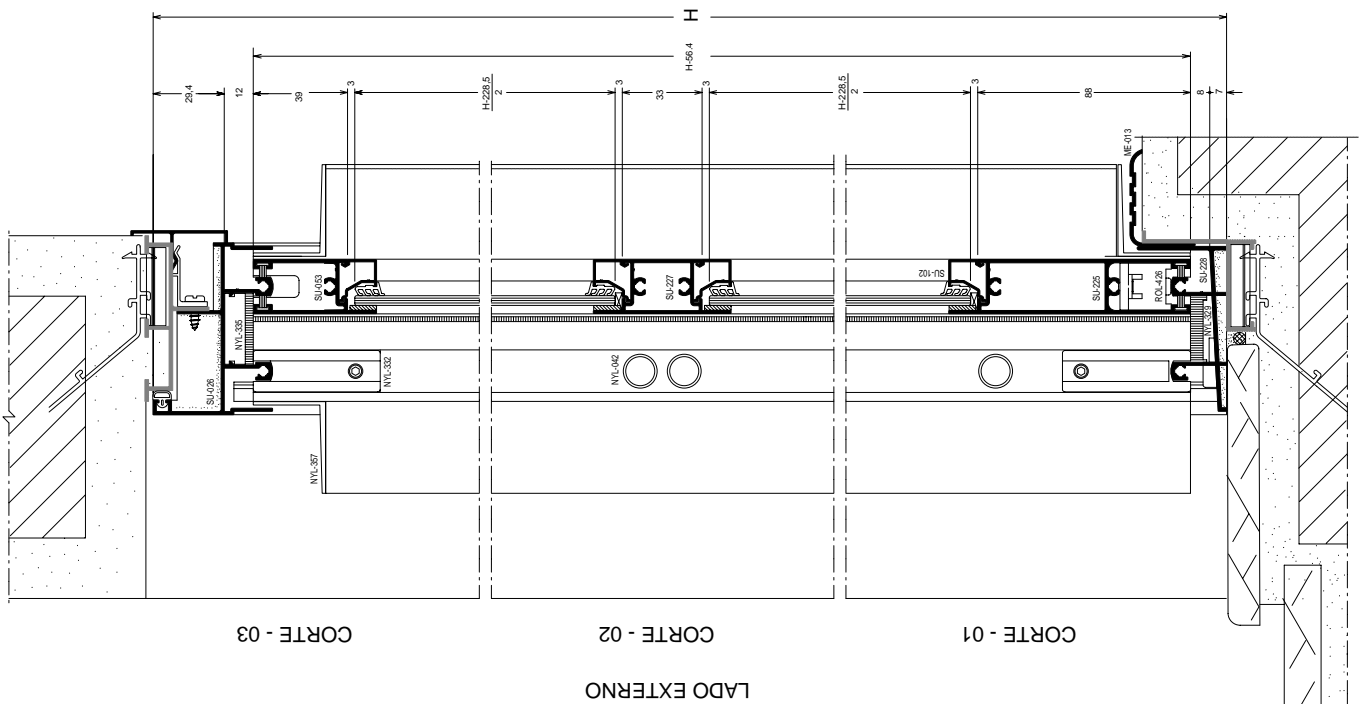
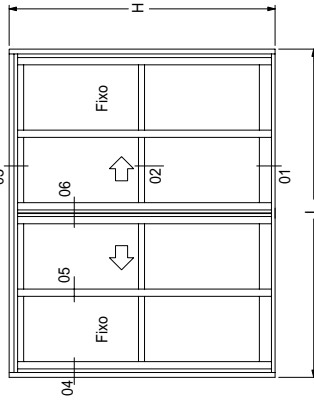

SUP PCR 400A



ELEVAÇÃO VISTA EXTERNA

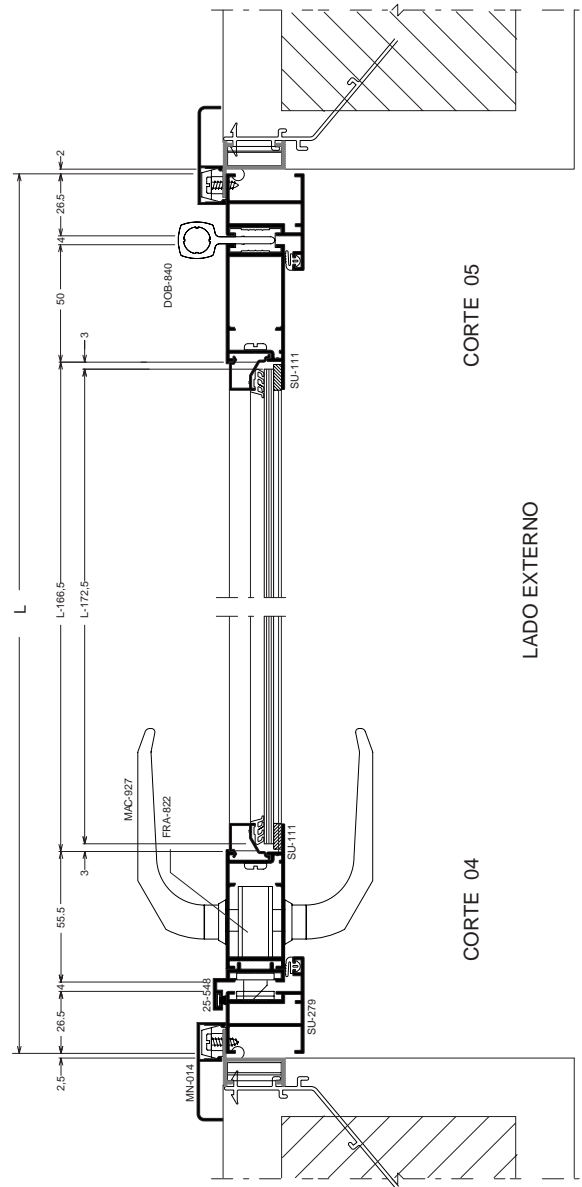
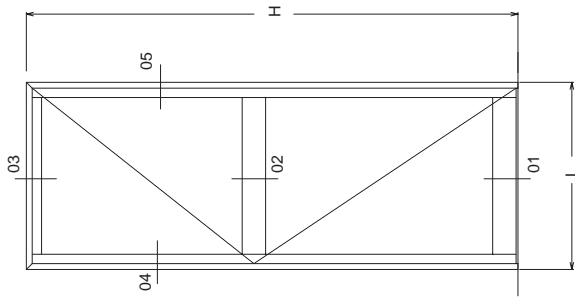

SUP PGR 100

LADO EXTERNO

CORTE 04

CORTE 05

LADO EXTERNO

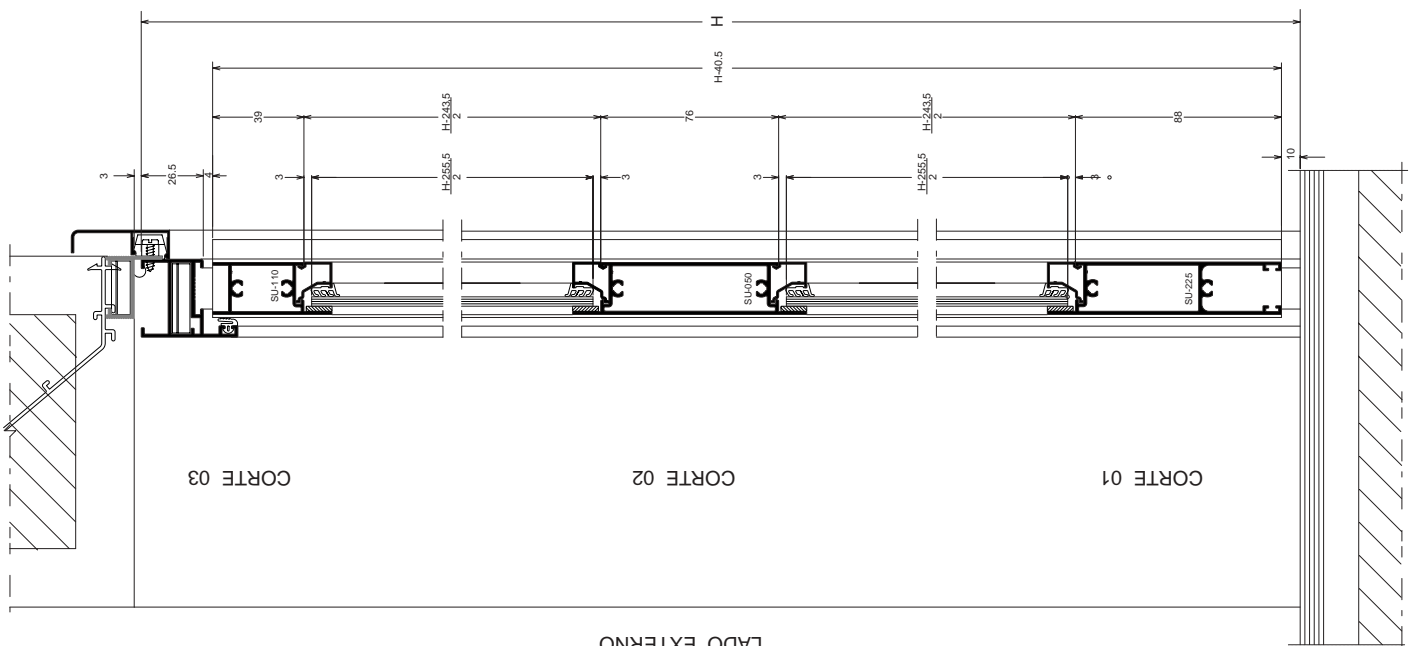

CORTE 03

CORTE 02

CORTE 01

ELEVAÇÃO VISTA EXTERNA

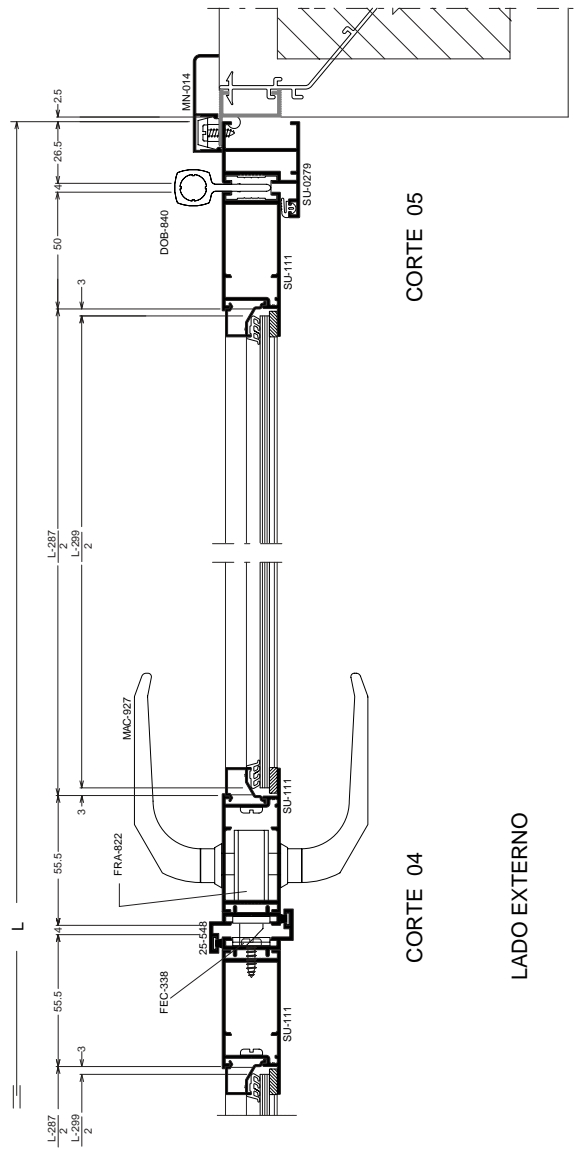
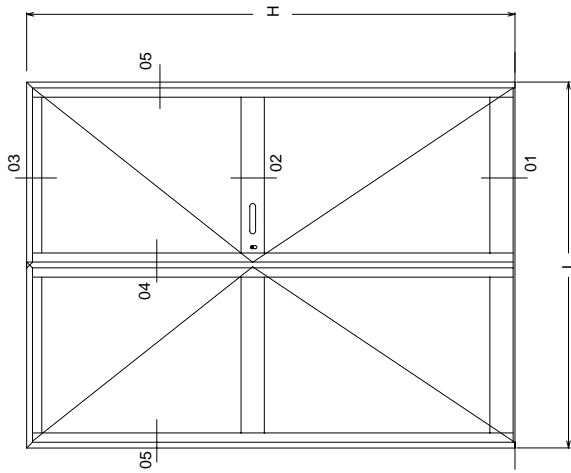

SUP PGR 200

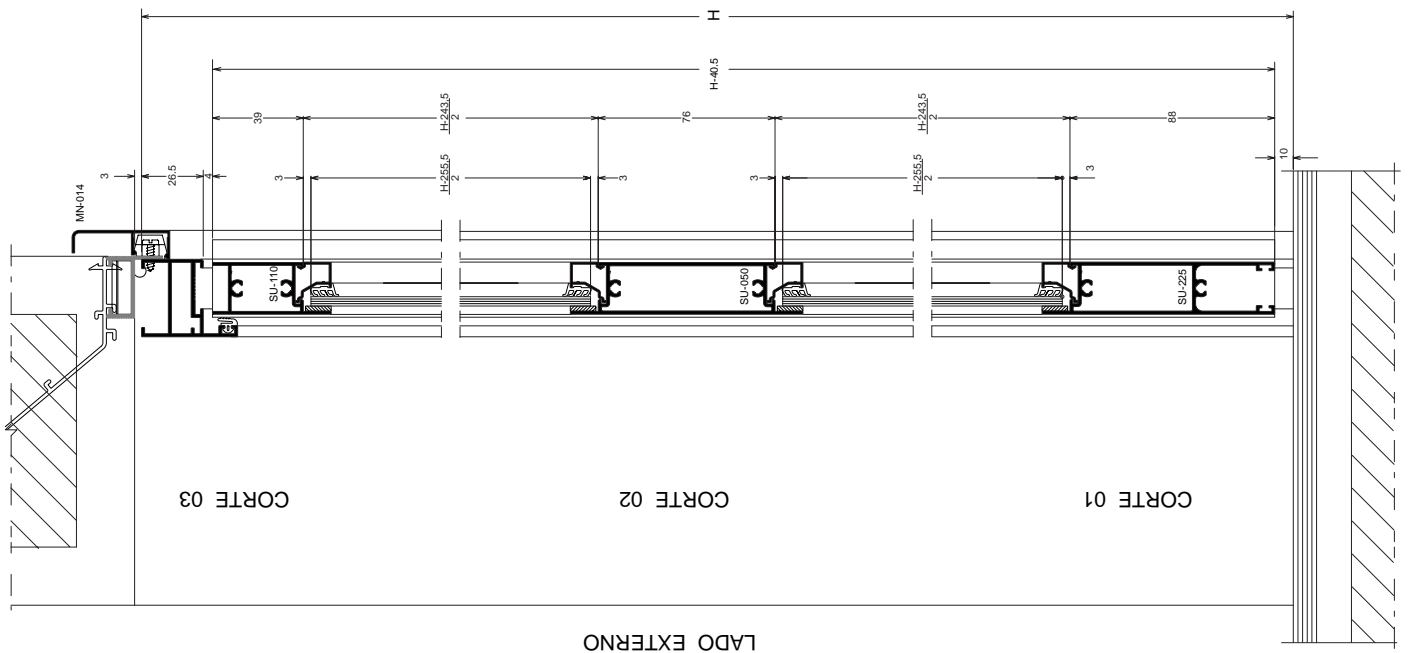

LADO EXTERNO

ELEVAÇÃO VISTA EXTERNA



TABELA DE BRAÇOS MAXIMAR

Código	Dimensões (mm)		Altura da folha (mm)	
	(A)	Máximo	Mínimo	Máximo
BRA-705	250	270	500	500
BRA-702	500	510	760	760
BRA-703	750	770	900	900

Braço reforçado

Código	Dimensões (mm)		Altura da folha (mm)	
	(A)	Máximo	Mínimo	Máximo
BRA-725	810	810	900	1200

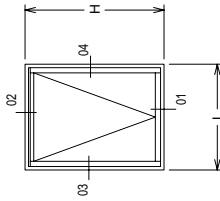
Espessura máxima de vidro = 6 mm

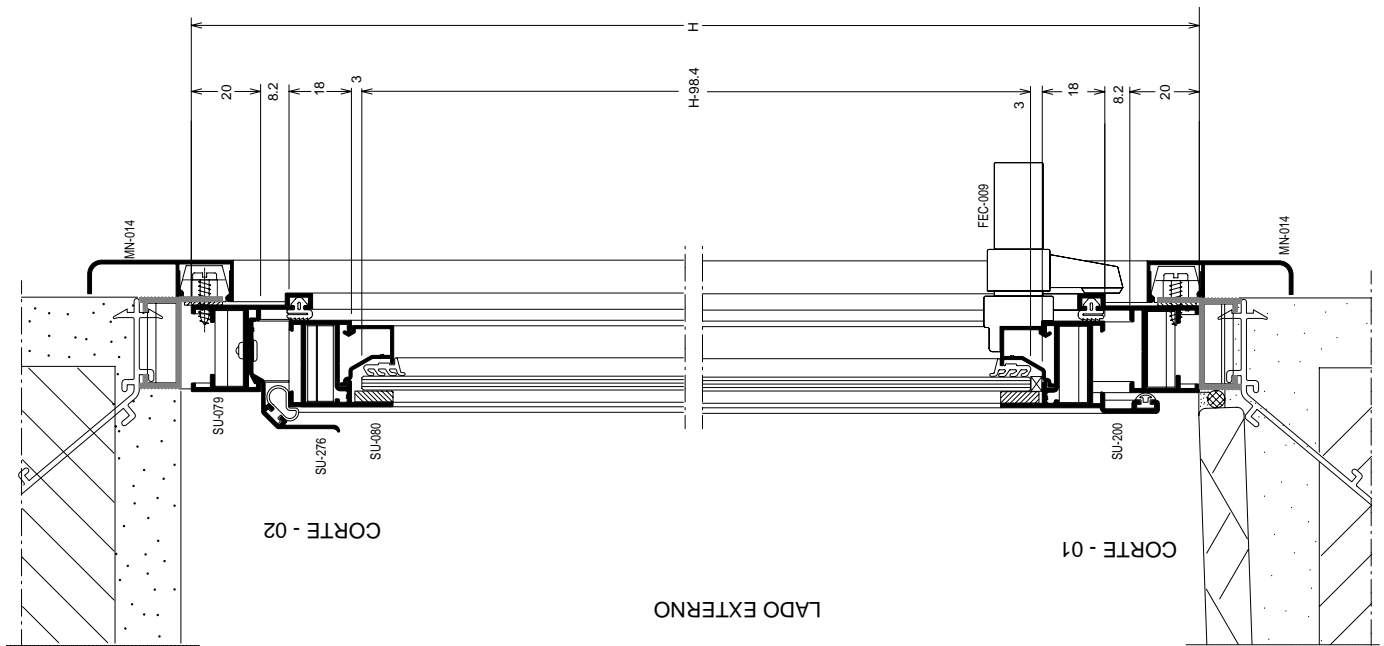







www.alcoa.com.br faleconosco@alcoa.com.br  
Central Alcoa de Atendimento ao Cliente 0800 159888

#### ESCRITÓRIOS COMERCIAIS

##### **Belo Horizonte**

Av. Antônio Abrahão Caran, 430 sl.707- Pampulha  
CEP 31275-000 - MG  
Tel (031) 3491-2700 Fax (031) 3491-4200

##### **Caxias do Sul**

Rua Marcos Moreschi, 50 - Sala 01 - Pio X  
CEP 95034-120 - RS  
Tel/Fax (054) 214-7177

##### **Curitiba**

Av. República Argentina, 50 cj. 51 - Água Verde  
CEP 80240-210 - PR  
Tel (041) 343-1160 Fax (041) 343-8021/342-1398

##### **Florianópolis**

Rua Doralice Ramos Pinho, 375 - Sala 04 - Barreiros  
CEP 88111-310 - SC  
Tel (048) 246-2222 Fax (048) 246-6366

##### **Fortaleza**

Av. Padre Antonio Tomás, 2073 - Aldeota  
CEP 60140-160 - CE  
Tel (085) 224-7755 Fax (085) 224-6700

##### **Porto Alegre**

Av. Souza Reis, 288 - Sala 201/2/3 São João  
CEP 90240-650 - RS  
Tel (051) 3343-2866 Fax (051) 3343-2229

##### **Recife**

Rod. PE - 35 km 3 - Itapissuma  
CEP 53700-000 - PE  
Tel (081) 3543-6868 Fax (081) 3543-6802

##### **Rio de Janeiro**

Av. das Américas, 700 - Bl. 6 - Sala 111  
Barra da Tijuca - RJ  
CEP 22640-100  
Tel (021) 2132-7272 Fax (021) 2132-7207

##### **Salvador**

Av. Tancredo Neves, 1632 Sala 307/ 308  
Ed. Salvador Trade Center - Torre Sul  
Caminho das Árvores  
CEP 41820-020 - BA  
Tel (071) 3113-1707/11 Fax (071) 3113-1708

##### **Santo André**

Rua Felipe Camarão, 454  
CEP 09220-580 - Utinga - SP  
Tel (011) 4463-8000 Fax (011) 4463-8447/8

##### **Vitória**

Rua José Alexandre Buaiz, 190  
Ed. Master Tower, Sl 617  
CEP 29055-221 - Bairro Enseada do Suá - ES  
Tel (027) 3314-3886 Fax (027) 3314-3896

#### CENTROS DE DISTRIBUIÇÃO - CDS

##### **Itapissuma**

Rodovia PE 35 km 3  
CEP 53700-000 - PE  
Tel (081) 3543-6600 Fax (081) 3543-1471

##### **Sorocaba**

Av. Independência, 415 Iporanga  
CEP 18087-050 Sorocaba-SP  
Tel (015) 238-3000 Fax (015) 238-3042

##### **Tubarão**

BR 101 - km 343  
CEP 88708-352 - SC  
Tel (048) 631-1000 Fax (048) 631-1030



## Call Centers Alcoa

 ☎ 0800 702 3014

 ☎ 0800 702 3012

 ☎ 0800 702 3007

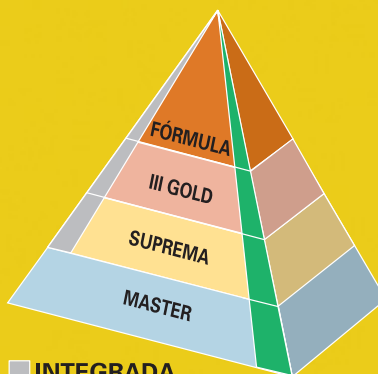

 INTEGRADA  
 GRADIL/PORTÃO

**RESIDENCIAL**

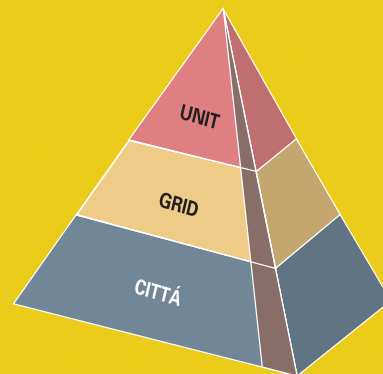

 REYNOBOND

**COMERCIAL**